

OWNER'S MANUAL
HONDA C-100 BIZ

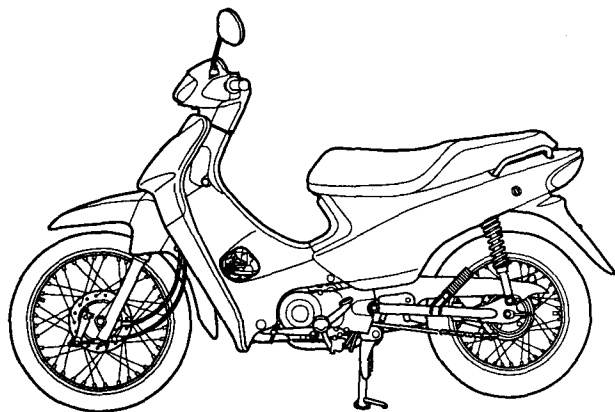

Moto Honda da Amazônia Ltda.

IMPORTANT NOTICE

- **OPERATOR AND PASSENGER**

This motorcycle is designed to carry the operator and one passenger.

- **ON-ROAD USE**

This motorcycle is designed to be used only on the road.

- **READ THIS OWNER'S MANUAL CAREFULLY**

Pay special attention to statements preceded by the following words:



Indicates a strong possibility of severe personal injury at death if instructions are not followed.



Indicates a possibility of personal injury or equipment damage if instructions are not followed.

NOTE

Gives helpful information.

This manual should be considered a permanent part of the motorcycle and should remain with the motorcycle when resold.

WELCOME

The motorcycle presents you a challenge to master the machine, a challenge to adventure. You ride through the wind, linked to the road by a vehicle that responds to your commands as no other does. Unlike an automobile, there is no metal cage around you. Like an airplane, a pre-ride inspection and regular maintenance are essential to your safety. Your reward is freedom.

To meet the challenges safely, and to enjoy the adventure fully you should become thoroughly familiar with this owner's manual **BEFORE YOU RIDE THE MOTORCYCLE**.

When service is required, remember that your Honda dealer knows your motorcycle best. If you have the required mechanical "know-how" and tools, your dealer can supply you with an official Honda Service Manual to help you perform many maintenance and repair tasks.

Pleasant riding, and thank you for choosing a Honda!

NOISE CONTROL SYSTEM (AUSTRALIA ONLY)

TAMPERING WITH THE NOISE CONTROL SYSTEM IS PROHIBITED: Owners are warned that the law may prohibit: (a) The removal or rendering inoperative by any person other than for the purposes of maintenance, repair or replacement, of any device or element of design incorporated into any new vehicle for the purpose of noise control prior to its sale or delivery to the ultimate purchaser or while it is in use; and (b) the use of the vehicle after such device or element of design has been removed or rendered inoperative by any person.

ALL INFORMATION IN THIS PUBLICATION IS BASED ON THE LATEST PRODUCTION INFORMATION AVAILABLE AT THE TIME OF APPROVAL FOR PRINTING. MOTO HONDA DA AMAZÔNIA LTDA. RESERVES THE RIGHT TO MAKE CHANGES AT ANY TIME WITHOUT NOTICE AND WITHOUT INCURRING ANY OBLIGATION. NO PART OF THIS PUBLICATION MAY BE REPRODUCED WITHOUT WRITTEN PERMISSION.

NOISE CONTROL SYSTEM (AUSTRALIA ONLY)

TAMPERING WITH THE NOISE CONTROL SYSTEM IS PROHIBITED: Owners are warned that the law may prohibit: (a) The removal or rendering inoperative by any person other than for the purposes of maintenance, repair or replacement, of any device or element of design incorporated into any new vehicle for the purpose of noise control prior to its sale or delivery to the ultimate purchaser or while it is in use; and (b) the use of the vehicle after such device or element of design has been removed or rendered inoperative by any person.

OPERATION

page

- 1 MOTORCYCLE SAFETY
 - 1 Safe Riding Rules
 - 2 Protective Apparel
 - 3 Modifications
 - 3 Loading and Accessories

- 5 PARTS LOCATION
 - 8 Instruments and Indicators

- 11 MAJOR COMPONENTS
(Information you need to operate
this motorcycle)
 - 11 Brakes
 - 14 Clutch
 - 15 Fuel
 - 18 Engine Oil
 - 19 Tyres

- 21 ESSENTIAL INDIVIDUAL COMPONENTS
 - 21 Ignition Switch
 - 22 Right Handlebar Controls
 - 23 Left Handlebar Controls

page

- 24 FEATURES
 - (Not required for operation)
 - 24 Steering Lock
 - 25 Seat Lock
 - 26 Helmet Holder
 - 27 Center Compartment
 - 28 Document Compartment
 - 29 Headlight Aim Vertical Adjustment
 - 30 Headlight Aim

- 31 OPERATION
 - 31 Pre-ride Inspection
 - 32 Starting the Engine
 - 35 Running-in
 - 36 Riding
 - 38 Braking
 - 39 Parking
 - 40 Anti-theft Tips

MAINTENANCE

page

41	MAINTENANCE
42	Maintenance Schedule
46	Tool Kit
47	Serial Numbers
48	Maintenance Precautions
49	Air Cleaner
51	Fuel Strainer Screen
53	Engine Oil
56	Spark Plug
58	Valve Clearance
60	Idle Speed
61	Drive Chain
66	Front and Rear Suspension Inspection
67	Wheel Removal
71	Brake Shoe Wear
72	Battery
76	Fuse Replacement
78	Stoplight Switch Adjustment
79	Bulb Replacement

page

83	CLEANING
85	STORAGE GUIDE
85	Storage
87	Removal from Storage
88	SPECIFICATIONS

MOTORCYCLE SAFETY



Motorcycle riding requires special efforts on your part to ensure your safety. Know these requirements before you ride:

Safe Riding Rules

1. Always make a pre-ride inspection (page 31) before you start the engine. You may prevent an accident or equipment damage.
2. Many accidents involve inexperienced riders. Most countries require a special motorcycle riding test or license. Make sure you are qualified before you ride. NEVER lend your motorcycle to an inexperienced rider.
3. Many automobile/motorcycle accidents happen because the automobile driver does not "see" the motorcyclist. Make yourself conspicuous to help avoid the accident that wasn't your fault:
 - Wear bright or reflective clothing.
 - Don't ride in another motorist's "blind spot."
4. Obey all national and local laws, and regulations.
 - Excessive speed is a factor in many accidents. Obey the speed limits, and NEVER travel faster than conditions warrant.
 - Signal before you make a turn or lane change. Your size and maneuverability can surprise other motorists.
5. Don't let other motorists surprise you. Use extra caution at intersections, parking lot entrances and exits, and driveways.
6. Keep both hands on the handlebars and both feet on the footpegs while riding. A passenger should hold on to the motorcycle or the operator with both hands and keep both feet on the passenger footpegs.

Protective Apparel

1. Most motorcycle accident fatalities are due to head injuries: ALWAYS wear a helmet. You should also wear a face shield or goggles as well as boots, gloves and protective clothing. A passenger needs the same protection.
2. The exhaust system becomes hot during operation, and it remains hot for a while after stopping the engine. Be careful not to touch the exhaust system while it is hot. Wear clothing that fully covers your legs.
3. Do not wear loose clothing which could catch on the control levers, kickstarter, footpegs, drive chain or wheels.

Modifications



Modification of the motorcycle, or removal of original equipment, may render the vehicle unsafe or illegal. Obey all national and local equipment regulations.

Loading and accessories



To prevent an accident, use extreme care when adding and riding with accessories and cargo. Addition of accessories and cargo can reduce a motorcycle's stability, performance and safe operating speed. Remember these performances may be reduced by installation of non-Honda accessories, improper loading, worn tyres and overall motorcycle condition, poor road or weather conditions. These general guidelines may help you decide whether or how to equip your motorcycle, and how to load it safely.

Loading

1. Keep cargo and accessory weight low and close to the center of the motorcycle. Load weight equally on both sides to minimize imbalance. As weight is located further from the motorcycle's center of gravity, handling is proportionally affected.
2. Adjust tyre pressure (page 19) to suit load weight and riding conditions.
3. Vehicle handling and stability can be adversely affected by loose cargo. Recheck cargo security and accessory mounts frequently.
4. Do not attach large or heavy items (such as a sleeping bag or tent) to the handlebars, fork, or fender. Unstable handling or slow steering response may result.

Accessories

Genuine Honda accessories have been specifically designed for and tested on this motorcycle. Because the factory cannot test all other accessories, you are personally responsible for proper selection, installation, and use of non-Honda accessories. Always follow the guidelines under Loading, and these:

1. Carefully inspect the accessory to make sure it does not obscure any lights, reduce ground clearance and banking angle, or limit suspension travel, steering travel or control operation.
2. Large fork-mounted fairings or windshields, or poorly designed or improperly mounted fairings can produce aerodynamic forces that cause unstable handling. Do not install fairings that decrease cooling air flow to the engine.
3. Accessories which alter your riding position by moving hands or feet away from controls may increase reaction time in an emergency.
4. Do not add electrical equipment that will exceed the motorcycle's electrical system capacity. A blown fuse could cause a dangerous loss of lights or engine power.
5. This motorcycle was not designed to pull a sidecar or trailer. Handling may be seriously impaired if so equipped.

MAJOR COMPONENTS

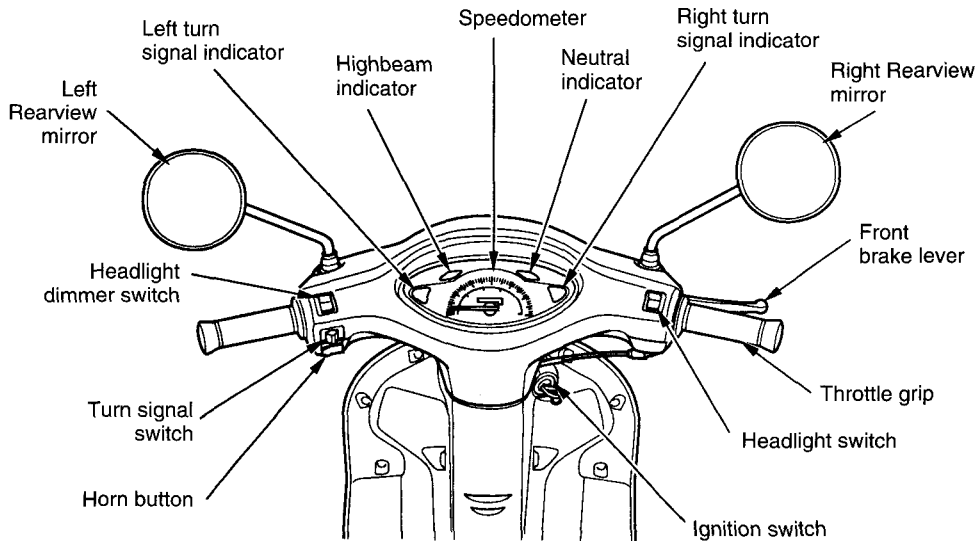

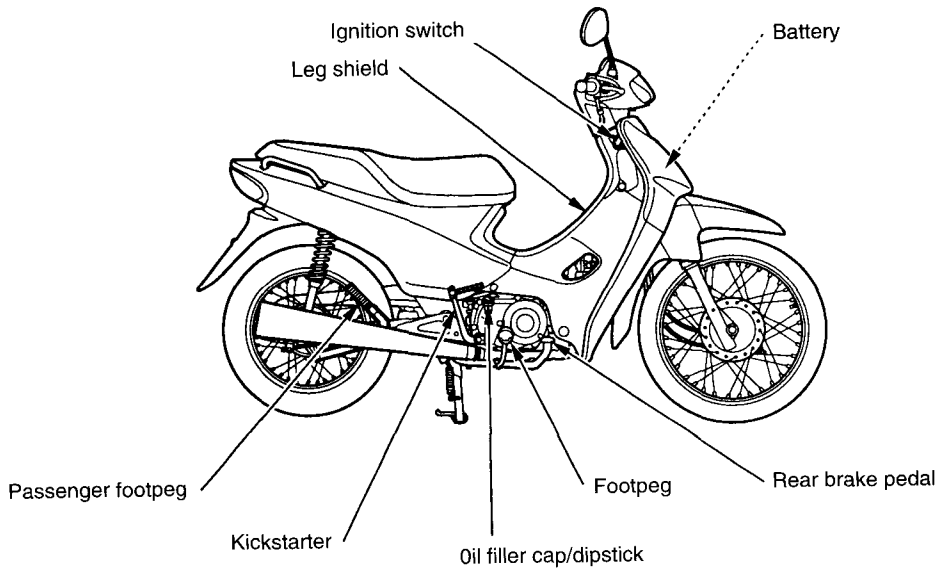

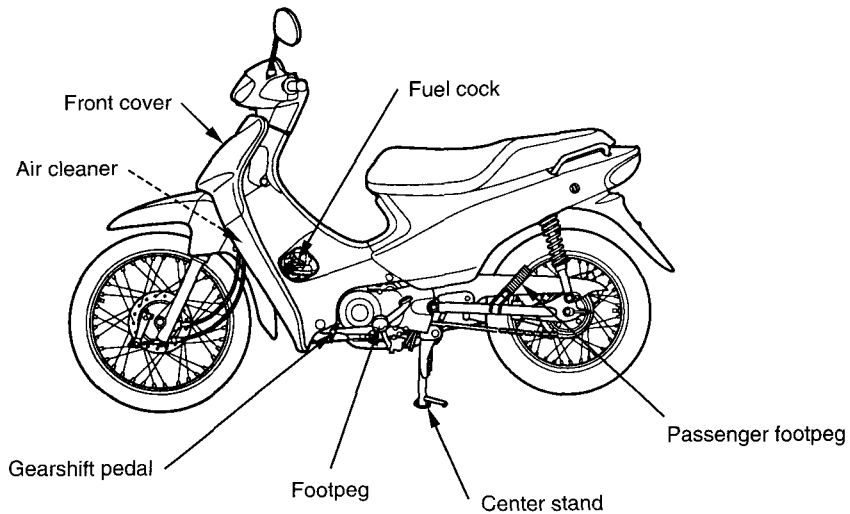

Instruments and Indicators

The indicators are grouped above the headlight case.

Their functions are described in the table on the following page.

- (1) Speedometer
- (2) Neutral indicator
- (3) Right turn signal indicator
- (4) Odometer
- (5) Left turn signal indicator
- (6) High beam indicator

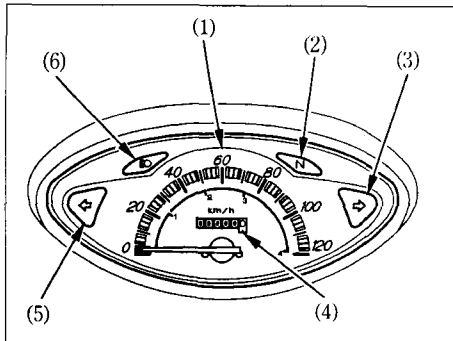

Ref. No.	Description	Function
1	Speedometer	Shows riding speed.
2	Neutral indicator	Lights when the transmission is in neutral.
3	Right turn signal indicator	Flashes when the right turn signal operates.
4	Odometer	Shows accumulated mileage.
5	Left turn signal indicator	Flashes when the left turn signal operates.
6	High beam indicator	Lights when the headlight is on high beam.

Fuel Gauge

The fuel gauge (1) is located under the seat. When the gauge needle enters the red band (2), fuel will be low and you should *refill* the tank as soon as possible. The amount of fuel left in the tank when the needle enters the red band is approximately:

1,3 ℓ (0.34 US gal, 0.29 Imp gal)

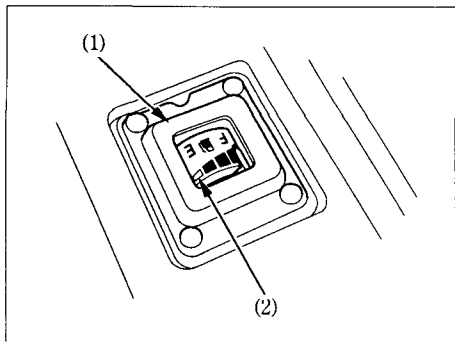

- (1) Fuel gauge
- (2) Red band

MAJOR COMPONENTS

(Information you need to operate this motorcycle)



If the Pre-ride Inspection (page 31) is not performed, severe personal injury or vehicle damage may result.

Brakes

Front Brake

Brakes are items of personal safety and should always be maintained in proper adjustment. The distance the front brake lever (1) moves before the brake starts to engage is called free play.

Measured at the tip of the front brake lever, free play should be maintained at:
10-20 mm (0.4-0.8 in)

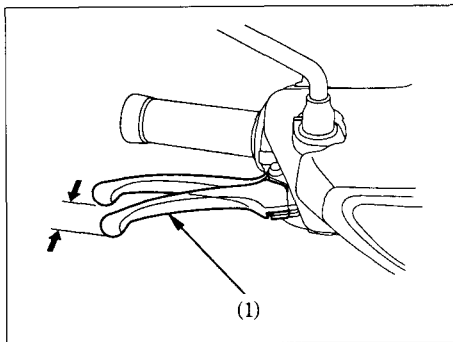

(1) Front brake lever

Adjustment:

1. Adjust brake lever free play with the front brake adjusting nut (1). Turning the nut clockwise will decrease free play and turning the nut counterclockwise will increase free play.
Make sure the cut-out on the adjusting nut is seated on the brake arm pin (2) after making final free play adjustment.
2. Apply the brake several times and check for free wheel rotation when released.

NOTE

If proper adjustment cannot be obtained by this method see your Honda dealer.

Other-Checks:

Check the brake cable for kinks or signs of wear that could cause sticking or failure. Lubricate the brake cable with a commercially available cable lubricant to prevent premature wear and corrosion. Make sure the brake arm, spring and fasteners are in good condition.

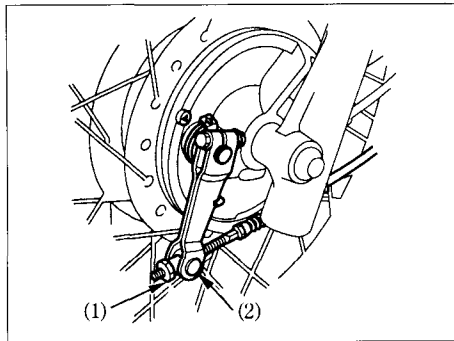

- (1) Front brake adjusting nut
- (2) Brake arm pin

Rear Brake

Adjustment:

1. Place the motorcycle on its center stand.
2. Measure the distance the rear brake pedal (1) moves before the brake starts to take hold.
Free play should be: 20-30 mm (0.8-1.2 in)
3. If adjustment is necessary, turn the rear brake adjusting nut (2).

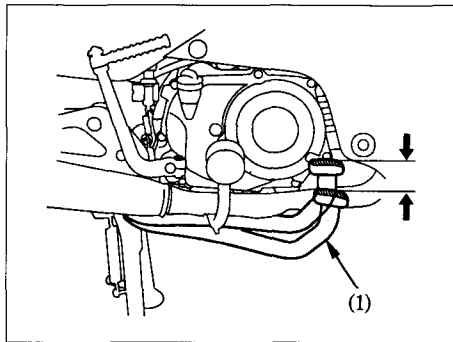

(1) Rear brake pedal

4. Apply brake several times and check for free wheel rotation when released.

NOTE

If proper adjustment cannot be obtained by this method see your Honda dealer.

Make sure the cut-out on the adjusting nut is seated on the brake arm pin (3) after making final free play adjustment.

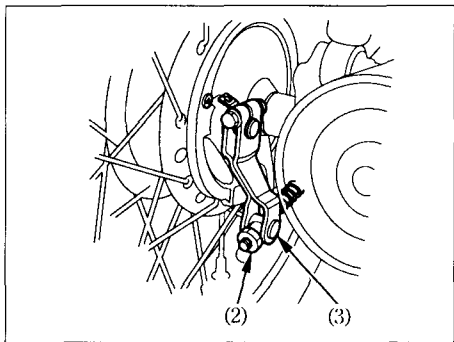

- (2) Rear brake adjusting nut
(3) Brake arm pin

Clutch

Adjustment:

1. Loosen the adjuster lock nut (1).
2. Turn the clutch adjuster (2) clockwise one turn; do not turn excessively.
3. Slowly turn the adjuster counterclockwise until a slight resistance is felt.
4. From this position, turn the adjuster clockwise 1/8 turn, and tighten the lock nut.
5. After adjustment, test ride the motorcycle to be certain the clutch operates properly. The engine should start easily with the kickstarter without the clutch slipping. When shifting gears, the clutch operation should be smooth and light, especially when shifting into neutral.

NOTE

If proper adjustment cannot be obtained or the clutch does not work correctly, see your Honda dealer.

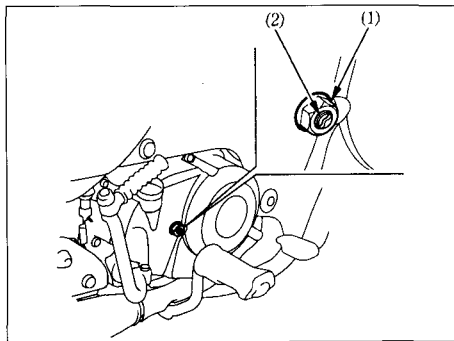

- (1) Lock nut
(2) Clutch adjuster

Fuel

Fuel Cock

The three way fuel cock (1) is on the left side near the carburetor.

OFF

With the fuel cock in the OFF position, fuel cannot flow from the tank to the carburetor. Turn the cock OFF whenever the motorcycle is not in use.

ON

With the fuel cock in the ON position, fuel will flow from the main fuel supply to the carburetor.



- **To avoid running out of fuel that may result in a sudden stop, learn how to operate the fuel cock when riding the motorcycle.**
- **Be careful not to touch any hot engine parts while operating the fuel cock.**

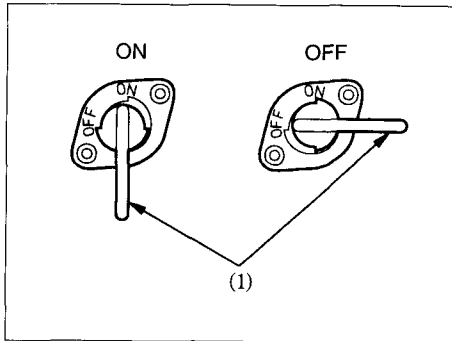

(1) Fuel cock

Fuel Tank

The fuel tank is located under the seat. To raise the double seat, unlock the seat (page 28).

The fuel tank capacity is: 4.0 ℓ (1.06 US gal,
0.88 Imp gal)

Raise the seat, then remove the fuel fill cap (1) by turning it counterclockwise.

After refueling, be sure to tighten the fuel fill cap firmly by turning it clockwise.

Make sure that the allow marks (2) on the fuel fill cap and fuel tank is aligned.

ATTENTION

If "spark knock" or "pinking" occurs at a steady engine speed under normal load, change brands of petrol. If spark knock or pinking persists, consult your Honda dealer. Failure to do so is considered misuse, and damage caused by misuse is not covered by Honda's Limited Warranty.

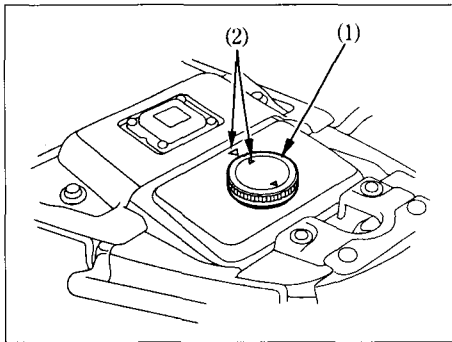

(1) Fuel fill cap

(2) Allow marks

⚠ WARNING

- **Petrol is extremely flammable and is explosive under certain conditions. Refuel in a well-ventilated area with the engine stopped. Do not smoke or allow flames or sparks in the area where petrol is stored or where the fuel tank is refueled.**
- **Do not overfill the tank (there should be no fuel in the filter neck (3)). After refueling, make sure the fuel fill cap is closed securely.**
- **Be careful not to spill fuel when refueling. Spilled fuel or fuel vapor may ignite. If any fuel is spilled, make sure the area is dry before starting the engine.**
- **Avoid repeated or prolonged contact with skin or breathing of vapor. KEEP OUT OF REACH OF CHILDREN.**

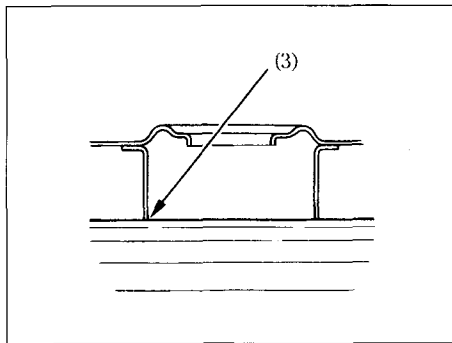

(3) Filler neck

Engine Oil ,

Engine Oil Level Check

Check the engine oil level each day before riding the motorcycle.

The level must be maintained between the upper (1) and lower (2) level marks on the dipstick (3).

1. Start the engine and let it idle for a few minutes.
2. Stop the engine and put the motorcycle on its center stand on level ground.
3. After a few minutes, remove the oil filler cap/dipstick (3), wipe it clean, and reinsert the dipstick without screwing it in. Remove the dipstick. The oil level should be between the upper (1) and lower (2) level marks on the dipstick.
4. If required, add the specified oil (see page 53) up to the upper level mark. Do not overfill.

5. Reinstall the oil filler cap/dipstick. Check for oil leaks.

ATTENTION

Running the engine with insufficient oil pressure may cause serious engine damage.

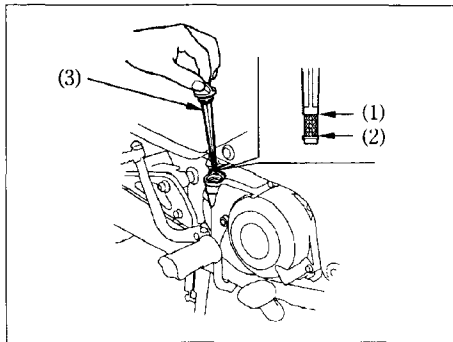

- (1) Upper level mark
- (2) Lower level mark
- (3) Oil filler cap/dipstick

Tyres

Proper air pressure will provide maximum stability, riding comfort and tyre life.

Check tyre pressure frequently and adjust if necessary.

NOTE

Tyre pressure should be checked before you ride while the tyres are "cold".

On-road tyres are standard on this model. Select the right replacement tyres in accordance with the following specifications. Check the tyres for cuts, embedded nails, or other sharp objects. See your Honda dealer for replacement of damaged tyres or punctured inner tubes.

Tyre size Cold tyre pressures (kPa)	Rider only	Front: 175 (1.75, 25) Rear: 225(2.00,29)
	Rider and one passenger	Front: 175 (1.75, 25) Rear: 280(2.80,41)
Tyre Size		Front:60/100-17 33L Rear: 80/100-14 M/C 49L

 **WARNING**

- **Do not attempt to patch a damaged tyre or inner tube. Wheel balance and tyre reliability may be impaired.**
- **Improper tyre inflation will cause abnormal tread wear and create a safety hazard. Underinflation may result in the tyre slipping on, or coming off of the rim causing tyre deflation that may result in a loss of vehicle control.**
- **Operation with excessively worn tyres is hazardous and will adversely affect traction and handling.**
- **The use of tyres other than those listed on the tyre information label may adversely affect handling.**

ESSENTIAL INDIVIDUAL COMPONENTS

Ignition Switch

The ignition switch (1) is on the right side below the steering stem.

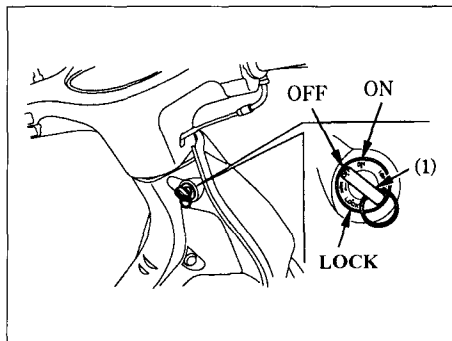

(1) Ignition switch

Key Position	Function	Key Removal
LOCK (steering lock)	Steering is locked. Engine and lights cannot be operated.	Key can be removed
OFF	Engine and lights cannot be operated.	Key can be removed
(ON)	Engine and lights can be operated.	Key cannot be removed

Right Handlebar Controls

Headlight Switch

The headlight switch (1) has two positions; $\equiv D$ and OFF marked by a dot under the $\equiv D$.

$\equiv D$: Headlight, taillight, and meter lights on,
OFF: Headlight, taillight, and meter (dot) lights off.

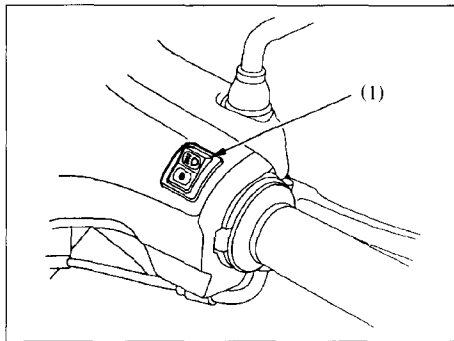

(1) Headlight switch

Left Handlebar Controls

Headlight Dimmer Switch (2)

Move the headlight dimmer switch to ☰▷ (Hi) to select high beam to ☷▷ (Lo) to select low beam.

Turn Signal Switch (3)

Move to L to signal a left turn, R to signal a right turn. Remember to return the switch to the center (off) after completing your turn or lane change.

Horn Button (4)

Press the button to sound the horn.

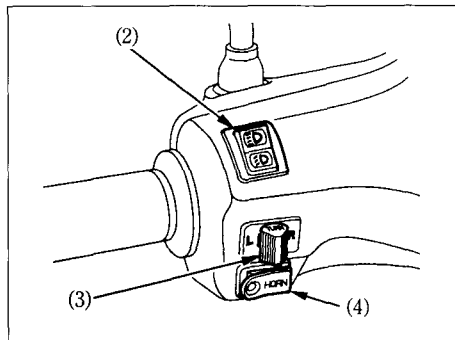

(2) Headlight dimmer switch

(3) Turn signal switch

(4) Horn button

FEATURES

(Not required for operation)

Steering Lock

To lock the steering, turn the handlebars all the way to the left; turn the key (1) to LOCK while pushing in. Remove the key.



Do not turn the key to LOCK while riding the motorcycle; loss of vehicle control will result.

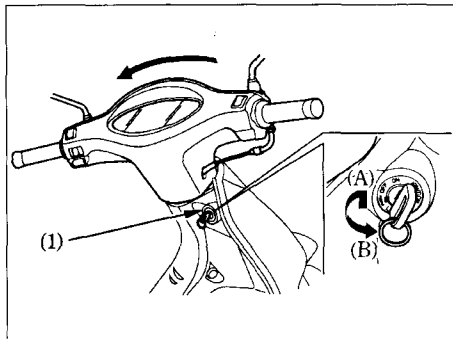

- (1) Steering lock
- (A) Push in
- (B) Turn to LOCK

Seat Lock

The seat lock (1), is on the left side below the seat.

To lift the seat, insert the ignition key (2) and turn it clockwise to unlock.

To lock the seat, lower and push down on it until it locks.

ATTENTION

Make sure the seat is secure before riding.

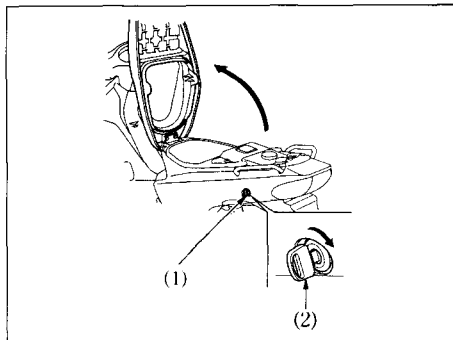

- (1) Seat lock
- (2) Ignition key

Helmet Holder

The helmet holder eliminates the need for carrying your helmet after parking. Insert the ignition key into the seat lock, and turn it clockwise to unlock. Hang your helmet (1) on the hook (2) at the seat hinge and lower the seat to lock. To remove a helmet, unlock the seat. Lift the helmet off the holder and lower the seat, making sure it is securely locked before riding.



The helmet holder is designed for helmet security while parked. Do not ride with a helmet attached to the holder; the helmet may interfere with safe operation and result in loss of control.

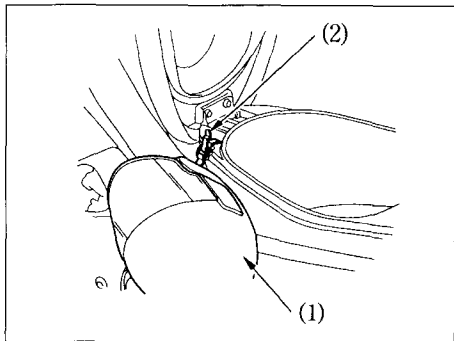

- (1) Helmet
- (2) Hook

Center Compartment

The center compartment (1) is below the seat.
Opening and closing:
See "SEAT LOCK". (page 25)

MAXIMUM WEIGHT LIMIT: 10 kg (22 lbs)



Never exceed the maximum weight limit; handling and stability may be severely affected.

ATTENTION

The center compartment may become heated by the engine. Do not store food and other articles which are flammable or susceptible to heat damage in this compartment.

NOTE:

Do not direct water under pressure against the center compartment as water will be forced into the compartment.

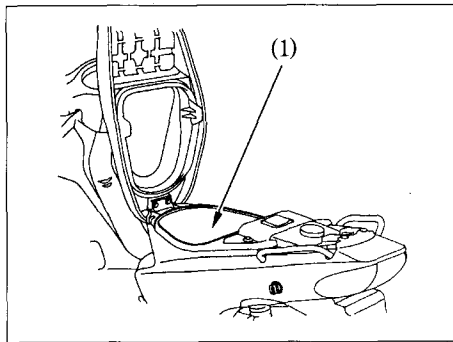

(1) Center compartment

Document Compartment

The document compartment (1) is located in the rear of the center compartment. This owner's manual and other documents should be stored in the document bag. When washing your motorcycle, be careful not to flood this area with water.

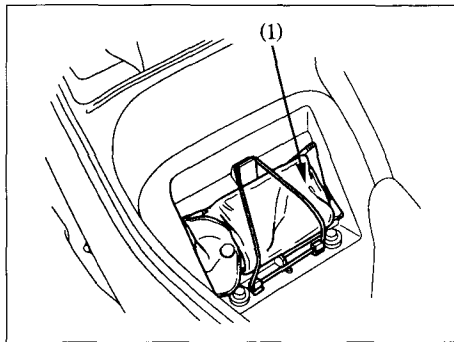

(1) Document compartment

Headlight Aim Vertical

Adjustment

Vertical adjustment can be made by moving the headlight assembly (1) as necessary.

To move the headlight assembly (1), loosen the bolt (2).

Tighten the bolt (2) after adjustment.

Obey local laws and regulations.

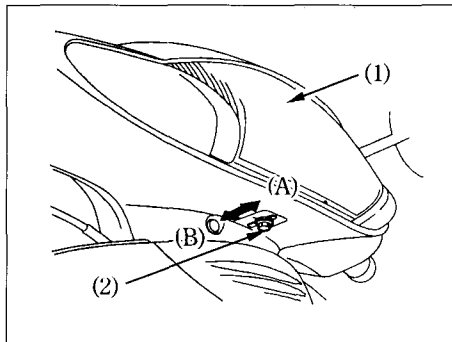

(1) Headlight assembly

(2) Bolt

(A) Up

(B) Down