

# HONDA

## OWNER'S MANUAL

### 97

### GL1500C

### VALKYRIE/Tourer



## **IMPORTANT INFORMATION**

- **OPERATOR AND PASSENGER**

This motorcycle is designed to carry the operator and one passenger. Never exceed the maximum weight capacity as shown on the tire information label.

- **ON-ROAD USE**

This motorcycle is not equipped with a spark arrester and is designed to be used only on the road. Operation in forest, brush or grass covered areas may be illegal. Obey local laws and regulations.

- **READ THIS OWNER'S MANUAL CAREFULLY**

Pay special attention to the safety messages that appear throughout the manual. These messages are fully explained in the "Safety Messages" section which appears opposite the Contents page.

This manual should be considered a permanent part of the motorcycle and should remain with the motorcycle when resold.

**HONDA GL1500C / CT  
VALKYRIE / Tourer  
OWNER'S MANUAL**

1997

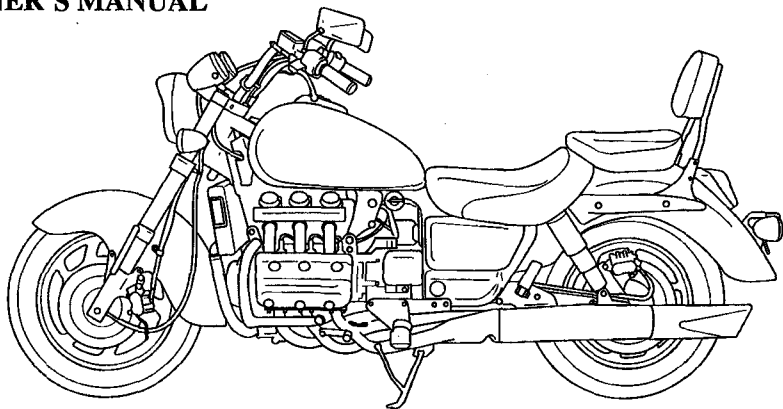

All information in this publication is based on the latest production information available at the time of approval for printing. HONDA MOTOR CO., LTD. reserves the right to make changes at any time without notice and without incurring any obligation.

No part of this publication may be reproduced without written permission.

© Honda Motor Co., Ltd. 1996

1

2

3

4

5

6

7

## WELCOME

Your new motorcycle presents you with an invitation to adventure and a challenge to master the machine. Your safety depends not only on your own alertness and familiarity with the motorcycle, but also the motorcycle's mechanical condition. A pre-ride inspection before every outing and regular maintenance are essential.

To help meet the challenges safely and enjoy the adventure fully, become thoroughly familiar with this Owner's Manual **BEFORE YOU RIDE THE MOTORCYCLE.**

Also for your own and your Honda's sake, please read all the written material which came with your new Honda. These items include:

- \* Honda Owner's Identification Card
- \* Honda Motorcycle Warranties Booklet
- \* Set-up and Pre-delivery Checklist (USA only)
- \* You And Your Motorcycle **RIDING TIPS & PRACTICE GUIDE (USA only)**

When service is required, remember that your Honda dealer knows what it takes to keep your Honda going strong. If you have the required mechanical "know-how" and tools, your dealer can supply you with an official Honda Service Manual to help you perform many maintenance and repair tasks.

Pleasant riding, and thank you for choosing a Honda!

## SAFETY MESSAGES

Your safety, and the safety of others, is very important. We have provided important safety messages in this manual and on your motorcycle. Please read these messages carefully.

A safety message alerts you to potential hazards that can hurt you and others. Each safety message is preceded by a safety alert symbol  and one of three words **DANGER**, **WARNING**, or **CAUTION**.

These mean:

**▲ DANGER**

You **WILL** be **KILLED** or **SERIOUSLY HURT** if you don't follow instructions.

**▲ WARNING**

You **CAN** be **KILLED** or **SERIOUSLY HURT** if you don't follow instructions.

**▲ CAUTION**

You **CAN** be **HURT** if you don't follow instructions.

Each message tells you what the hazard is, what can happen, and what you can do to avoid or reduce injury.

### Damage Prevention Messages

You will also see other important messages that are preceded by the word **NOTICE**.

This word means:

**NOTICE**

Your motorcycle or other property can be damaged if you don't follow instructions.

The purpose of these messages is to help prevent damage to your Honda, other property, or the environment.

# OPERATION

Page		Page	
1	MOTORCYCLE SAFETY	36	Right Handlebar Controls
1	Important Safety Information	37	Left Handlebar Controls
3	Protective Apparel		
5	Loading, Accessories and Modification	38	FEATURES (Not required for operation)
9	Safety Labels	38	Steering Lock
		39	Seat
11	PARTS LOCATION	40	Helmet Holder
14	Instruments and Indicators	41	Owner's Manual Storage
		42	Side Cover
17	MAJOR COMPONENTS (Information you need to operate this motorcycle)	43	Accessory (ACC) Terminal
17	Suspension	44	Saddlebags (GL1500CT only)
18	Brakes		
20	Clutch	45	OPERATION
21	Coolant	45	Pre-ride Inspection
23	Fuel	47	Starting the Engine
27	Engine Oil	51	Break-in
28	Final Drive Oil	52	Shifting
29	Tires	54	Braking
		55	High Altitude Riding
35	ESSENTIAL INDIVIDUAL COMPONENTS	56	Parking
35	Ignition Switch	57	Anti-theft Tips

# MAINTENANCE

Page

58	MAINTENANCE
58	The Importance of Maintenance
59	Maintenance Safety
60	Safety Precautions
61	Emission Requirements
62	Maintenance Schedule
65	Maintenance Record
66	Tool Kit
67	Serial Numbers
68	Color Label
69	FILTERS/LUBRICATION
69	Engine Oil
73	Crankcase Breather
74	ENGINE
74	Spark Plugs
76	Throttle Operation
77	Idle Speed
78	Coolant

Page

79	DRIVE TRAIN
79	Final Drive Oil
80	FRAME /WHEELS /BRAKES
80	Brake Pad Wear
82	Side Stand
83	Wheel Removal
93	ELECTRICAL
93	Battery
96	Fuses
100	CLEANING
102	STORAGE GUIDE
105	SPECIFICATIONS
109	CONSUMER INFORMATION
109	Service Manuals
110	Emission Control System
113	Warranty Service
114	Reporting Safety Defects

# MOTORCYCLE SAFETY

## IMPORTANT SAFETY INFORMATION

Your motorcycle can provide many years of service and pleasure — if you take responsibility for your own safety and understand the challenges that you can meet on the road.

There is much that you can do to protect yourself when you ride. You'll find many helpful recommendations throughout this manual. Following are a few that we consider most important.

### **Always Wear a Helmet**

It's a proven fact: Helmets significantly reduce the number and severity of head injuries. So always wear a helmet and make sure your passenger does the same. We also recommend that you wear eye protection, sturdy boots, gloves and other protective gear (page 3 ).

### **Take a Rider Training Course**

Because many accidents involve inexperienced or untrained riders, we urge all riders to take a certified course approved by the Motorcycle Safety Foundation (MSF).

New riders should start with the basic course, and even experienced riders will find the advanced course beneficial. For information about the MSF training course nearest you, call the national toll-free number (800) 446-9227 (USA only).

### **Ride Defensively**

The most frequent motorcycle collision happens when a car turns left in front of a motorcycle. Another common situation is a car moving suddenly into your lane. Always pay attention to other vehicles around you, and do not assume that other drivers see you.

Be prepared to stop quickly or make an evasive maneuver. For other riding tips, see the booklet, *You and Your Motorcycle: Riding Tips and Practice Guide*, which came with your new motorcycle (USA only).

**Make Yourself Easy to See**

Some drivers do not see motorcycles because they are not looking for them. To make yourself more visible, wear bright reflective clothing, position yourself so other drivers can see you, signal before turning or changing lanes, and use your horn when it will help others notice you.

**Ride Within Your Limits**

Pushing the limits is another major cause of motorcycle accidents. Never ride beyond your personal abilities or faster than conditions warrant. Remember that alcohol, drugs, fatigue and inattention can significantly reduce your ability to make good judgements and ride safely.

**Keep Your Bike in Safe Condition**

For safe riding, it's important to inspect your motorcycle before every ride and perform all recommended maintenance. Never exceed load limits, and only use accessories that have been approved by Honda for this motorcycle. See page 5 for more details.

## PROTECTIVE APPAREL

For your safety, we strongly recommend that you always wear an approved motorcycle helmet, eye protection, boots, gloves, long pants, and a long-sleeved shirt or jacket whenever you ride. Although complete protection is not possible, wearing proper gear can reduce the chance of injury when you ride. Following are suggestions to help you choose proper gear.

### **⚠ WARNING**

Not wearing a helmet increases the chance of serious injury or death in a crash.

Be sure you and your passenger always wear a helmet, eye protection and other protective apparel when you ride.

## Helmets and Eye Protection

Your helmet is your most important piece of riding gear because it offers the best protection against head injuries. A helmet should fit your head comfortably and securely. A bright-colored helmet can make you more noticeable in traffic, as can reflective strips.

An open-face helmet offers some protection, but a full-face helmet offers more. Regardless of the style, look for a DOT (Department of Transportation) sticker in any helmet you buy (USA only), and always wear a face shield or goggles to protect your eyes and help your vision.

### **Additional Riding Gear**

In addition to a helmet and eye protection, we also recommend:

- Sturdy boots with non-slip soles to help protect your feet and ankles.
- Leather gloves to keep your hands warm and help prevent blisters, cuts, burns and bruises.
- A motorcycle riding suit or jacket for comfort as well as protection. Bright-colored and reflective clothing can help make you more noticeable in traffic. Be sure to avoid loose clothes that could get caught on any part of your motorcycle.

## LOADING, ACCESSORIES AND MODIFICATIONS

Your motorcycle has been designed to carry you and one passenger (GL1500CT : and cargo and accessories). When you carry a passenger (GL1500CT : or add cargo), you may feel some difference during acceleration and braking. But so long as you keep your motorcycle well-maintained, with good tires and brakes, you can safely carry loads within the given limits and guidelines.

However, exceeding the weight limit or carrying an unbalanced load can seriously affect your motorcycle's handling, braking and stability. Non-Honda accessories, improper modifications, and poor maintenance can also reduce your safety margin.

The following pages give more specific information on loading, accessories and modifications.

### Loading

How much weight you put on your motorcycle, and how you load it, are important to your safety. Anytime you ride with a passenger or cargo you should be aware of the following information.

## **⚠ WARNING**

Overloading or improper loading can cause a crash and you can be seriously hurt or killed.

Follow all load limits and other loading guidelines in this manual.

## Load Limits

Following are the load limits for your motorcycle:

### Maximum weight capacity:

180 kg (397 lbs)

Includes the weight of the rider, passenger, all cargo and all accessories

### Maximum cargo weight:

each saddlebag

(GL1500CT only): 9.0 kg (20.0 lbs)

of all cargo: 27 kg (60 lbs)

## Loading Guidelines

Your motorcycle is primarily intended for transporting you and a passenger. You may wish to secure a jacket or other small items to the seat when you are not riding with a passenger. (GL1500C only)

If you wish to carry more cargo, check with your Honda dealer for advice, and be sure to read the information regarding accessories on page 7 . (GL1500C only)

Improperly loading your motorcycle can affect its stability and handling. Even if your motorcycle is properly loaded, you should ride at reduced speeds and never exceed 80 mph (130 km/h) when carrying cargo.

Follow these guidelines whenever you carry a passenger or cargo:

- Check that both tires are properly inflated and that pressure in the rear tire is increased to suit the load (page 30).
- If you change your normal load, you may need to adjust the rear suspension (page 17 ).
- To prevent loose items from creating a hazard, make sure that all cargo is securely tied down before you ride away.
- Place cargo weight as close to the center of the motorcycle as possible.
- Balance cargo weight evenly on both sides.
- Do not attach large or heavy items (such as a sleeping bag or tent) to the handlebars, forks or fender.

### Accessories and Modifications

Modifying your motorcycle or using non-Honda accessories can make your motorcycle unsafe. Before you consider making any modifications or adding an accessory, be sure to read the following information.

## **⚠ WARNING**

Improper accessories or modifications can cause a crash in which you can be seriously hurt or killed.

Follow all instructions in this owner's manual regarding accessories and modifications.

### Accessories

We strongly recommend that you use only genuine Honda accessories that have been specifically designed and tested for your motorcycle. Because Honda cannot test all other accessories, you must be personally responsible for proper selection, installation and use of non-Honda accessories. Check with your dealer for assistance and always follow these guidelines:

- Make sure the accessory does not obscure any lights, reduce ground clearance and banking angle, limit suspension travel or steering travel, alter your riding position or interfere with operating any controls.
- Do not install any fairing or windshield unless it was designed and tested by Honda for your motorcycle. Some fairings or windshields, even smaller ones, can cause unstable handling of your motorcycle. This is especially true if the fairing or windshield is poorly designed or improperly mounted.

- Be sure electrical equipment does not exceed the motorcycle's electrical system capacity (pages 43, 108 ). A blown fuse can cause a loss of lights or engine power.
- Do not pull a trailer or sidecar with your motorcycle. This motorcycle was not designed for these attachments, and their use can seriously impair your motorcycle's handling.

### **Modifications**

We strongly advise you not to remove any original equipment or modify your motorcycle in any way that would change its design or operation. Such changes could seriously impair your motorcycle's handling, stability and braking, making it unsafe to ride.

Removing or modifying your lights, mufflers, emission control system or other equipment can also make your motorcycle illegal.

## SAFETY LABELS

The following shows the locations of safety labels on your motorcycle. Some labels warn you of potential hazards that could cause serious injury. Others provide important safety information. Read these labels carefully and don't remove them.

If a label comes off or becomes hard to read, contact your Honda dealer for a replacement.

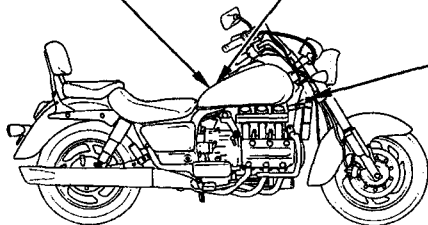
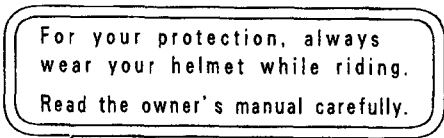
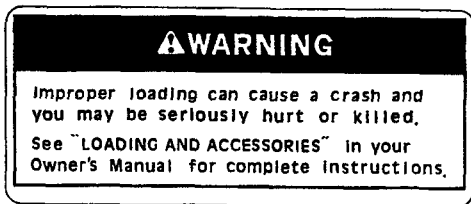

### TIRE INFORMATION

COLD TIRE PRESSURES :  
 [UP TO MAXIMUM WEIGHT CAPACITY] FRONT 225kPa 2.25kgf/cm<sup>2</sup> 33psi.  
 REAR 250kPa 2.50kgf/cm<sup>2</sup> 36psi.  
 [UP TO 90kg (200lbs.) LOAD] FRONT 225kPa 2.25kgf/cm<sup>2</sup> 33psi.  
 REAR 225kPa 2.25kgf/cm<sup>2</sup> 33psi.  
 MAXIMUM WEIGHT CAPACITY : 180 kg (397 lbs.)  
 TIRE SIZE : FRONT 150/80R17 72H REAR 160/70R16 77H

TIRE BRAND	FRONT	REAR
DUNLOP	D206F	D206

*Read Owner's Manual*

MIN.RECOMMEND TIRE CENTER TREAD DEPTH  
 FRONT 1.5mm(0.06in.) REAR 2.0mm(0.08in.)

THIS MOTORCYCLE IS EQUIPPED  
 WITH TUBELESS TIRES.

<GL1500CT only>

CARGO LIMIT

9.0kg / 20.0 lbs

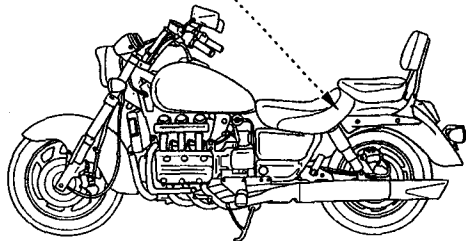

GL1500C

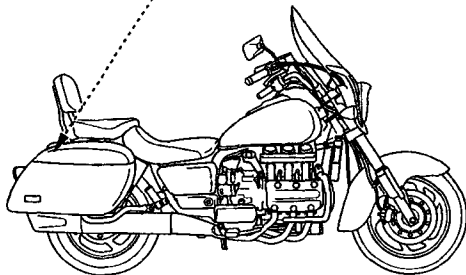

GL1500CT

## PARTS LOCATION

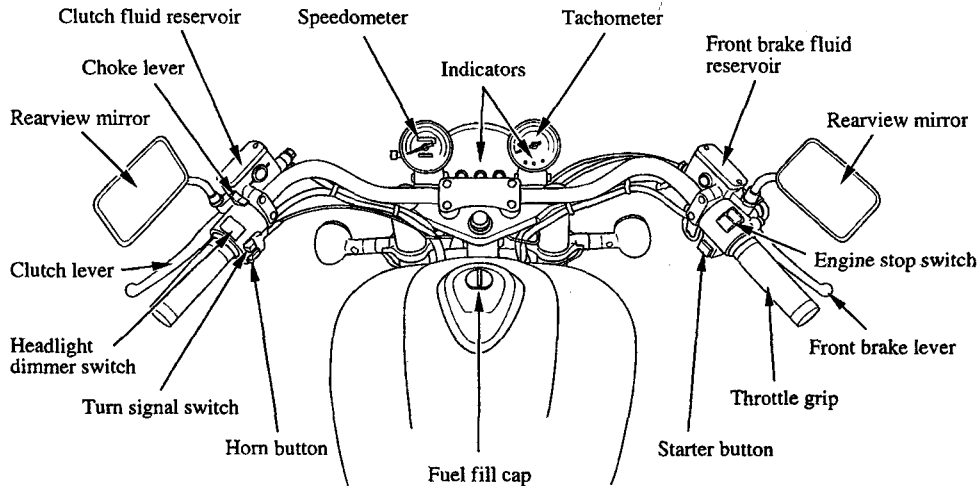

## GL1500C

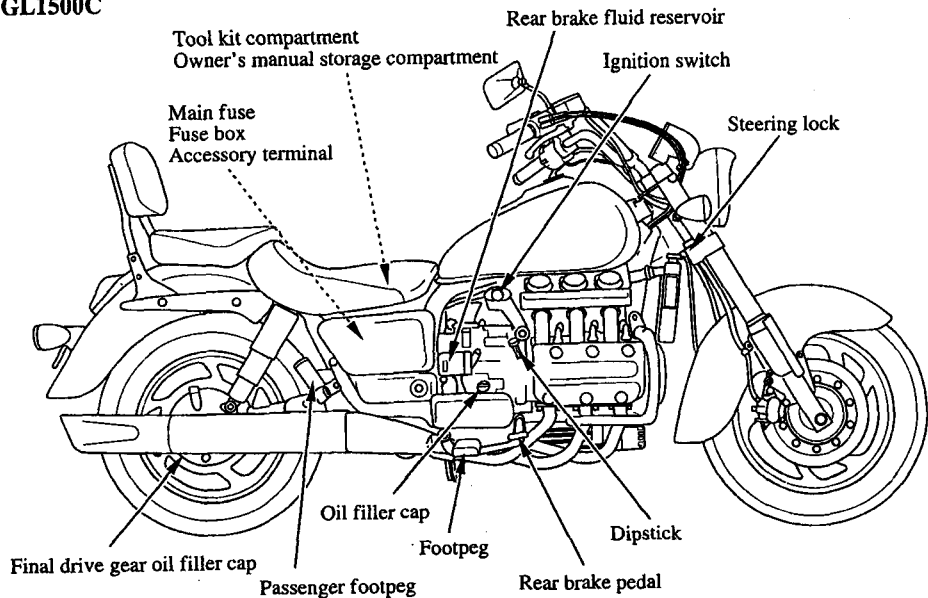

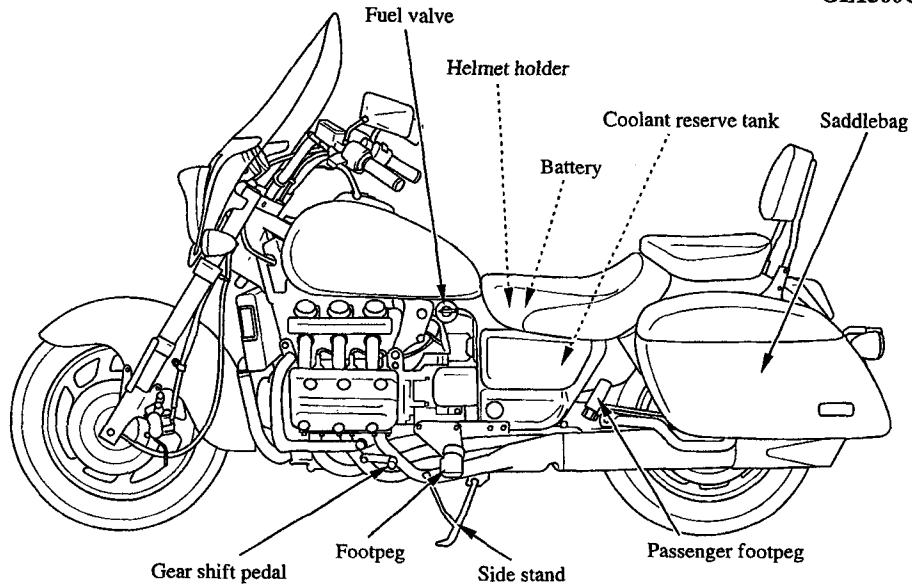

## INSTRUMENTS AND INDICATORS

The indicators are located within and below the instruments. Their functions are described in the tables on the following pages.

### USA model:

Odometer and tripmeter read in miles.

### Canadian model:

Odometer and tripmeter read in kilometers.

- (1) Speedometer
- (2) Odometer
- (3) Tachometer
- (4) Tachometer red zone
- (5) Side stand indicator
- (6) Low oil pressure indicator
- (7) Coolant temperature indicator
- (8) High beam indicator
- (9) Turn signal indicator
- (10) Neutral indicator
- (11) Tripmeter
- (12) Tripmeter reset knob

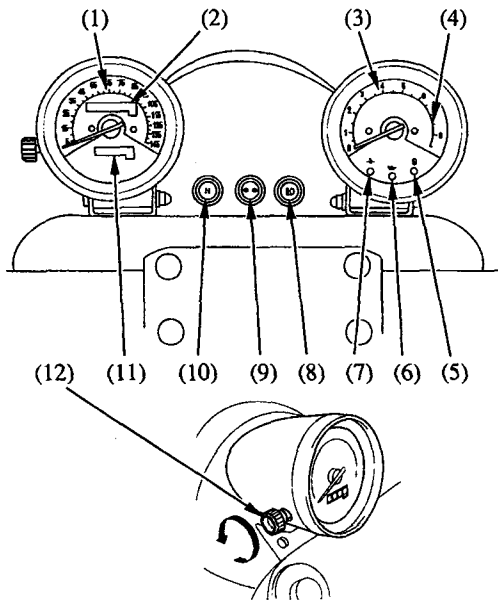

<b>(Ref.No.) Description</b>	<b>Function</b>
(1) Speedometer	Shows riding speed.
(2) Odometer	Shows accumulated mileage.
(3) Tachometer	Shows engine rpm.
(4) Tachometer red zone	Shows excessive engine rpm range in which operation may damage the engine.
(5) Side stand indicator (amber)	Lights when the side stand is put down. Before parking, check that the side stand is fully down; the light only indicates the side stand ignition cut-off system (page 47 ) is activated.
(6) Low oil pressure indicator (red)	Lights when the engine oil pressure is below the normal operating range. Should light when ignition switch is ON and engine is not running. Should go out when the engine starts, except for occasional flickering at or near idling speed when engine is warm.

<b>(Ref.No.) Description</b>	<b>Function</b>
(7) Coolant temperature indicator (red)	<p>Lights when the coolant is over the specified temperature.</p> <p>If the indicator goes on while riding, stop the engine and check the reserve tank coolant level. Read pages 21 - 22 and do not ride the motorcycle until the problem has been corrected.</p> <p>Exceeding maximum running temperature can cause serious engine damage.</p>
(8) High beam indicator (blue)	Lights when the headlight is on high beam.
(9) Turn signal indicator (amber)	Flashes when either turn signal is operated.
(10) Neutral indicator (green)	Lights when the transmission is in neutral.
(11) Tripmeter	Shows mileage per trip.
(12) Tripmeter reset knob	Resets tripmeter to zero (0) by turning the knob in direction shown.

## MAJOR COMPONENTS (Information you need to operate this motorcycle)

### SUSPENSION

Each shock absorber (1) has 5 adjustment positions for different load or riding conditions. Use the pin spanner (2) and extension bar (3) to adjust the rear shock.

Always adjust the shock absorber position in sequence (1-2-3-4-5 or 5-4-3-2-1).

Attempting to adjust directly from 1 to 5 or 5 to 1 may damage the shock absorber.

Position 1 is for a light load and smooth road conditions.

Position 2 is the standard position.

Positions 3 to 5 increase spring preload for a stiffer rear suspension and can be used when the motorcycle is more heavily loaded.

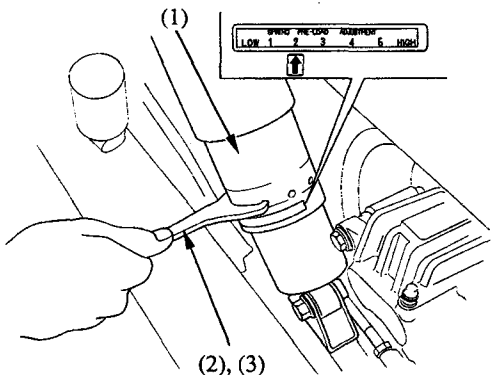

(1) Shock absorber  
(2) Pin spanner

(3) Extension bar

## **BRAKES**

Both front and rear brakes are hydraulic disc types.

As the brake pads wear, the brake fluid level will drop. A leak in the system will also cause the level to drop. Therefore, the brake fluid level and pad wear must be inspected periodically. The system must be inspected frequently to ensure there are no fluid leaks. If the control lever or pedal free travel becomes excessive and the brake pads are not worn beyond the recommended limit (page 79) there is probably air in the brake system and it must be bled. See your authorized Honda dealer for this service.

### Front Brake Fluid Level:

With the motorcycle in an upright position, check the fluid level. It should be above the LOWER level mark (1). If the level is at or below the LOWER level mark (1), check the brake pads for wear (page 80).

Worn pads should be replaced. If the pads are not worn, have your brake system inspected for leaks.

The recommended brake fluid is Honda DOT 4 brake fluid from a sealed container, or an equivalent.

### **Front**

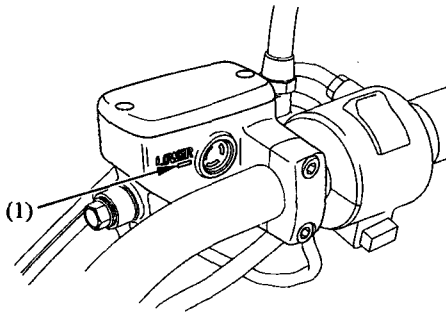

(1) LOWER level mark

### Rear Brake Fluid Level:

With the motorcycle in an upright position, check the fluid level. It should be between the UPPER (1) and LOWER (2) level marks. If the level is at or below the LOWER level mark (2), check the brake pads for wear (page 81 ).

Worn pads should be replaced. If the pads are not worn, have your brake system inspected for leaks.

The recommended brake fluid is Honda DOT 4 brake fluid from a sealed container, or an equivalent.

### Rear

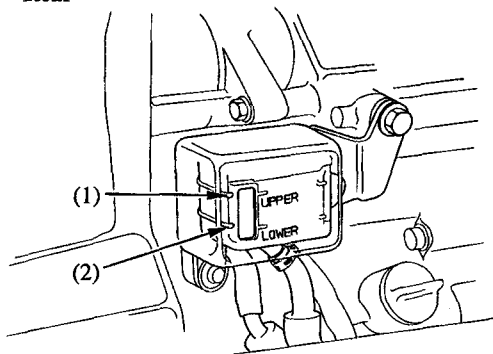

- (1) UPPER level mark
- (2) LOWER level mark

## CLUTCH

This motorcycle has a hydraulically actuated clutch. There are no adjustments to perform but the clutch system must be inspected periodically for fluid level and leakage. If the control lever freeplay becomes excessive and the motorcycle creeps or stalls when shifted into gear, or if the clutch slips, causing acceleration to lag behind engine speed, there is probably air in the clutch system and it must be bled out. See your authorized Honda dealer for this service.

### Fluid Level:

Check that the fluid level is above the LOWER level mark (1). If the fluid level is near the LOWER level mark, it indicates fluid leakage. See your authorized Honda dealer.

### Other checks:

Make sure there are no fluid leaks. Check for deterioration or cracks in the hoses and fittings.

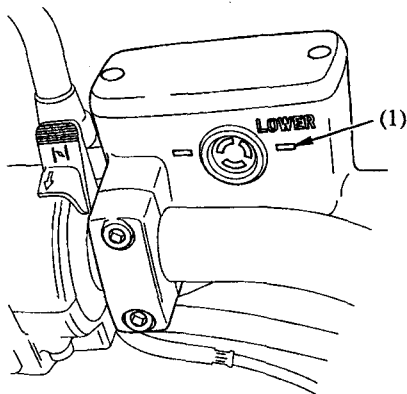

(1) LOWER level mark

## **COOLANT**

### **Coolant Recommendation**

The owner must properly maintain the coolant to prevent freezing, overheating and corrosion. Use only high quality ethylene glycol antifreeze containing corrosion protection inhibitors specifically recommended for use in aluminum engines. (SEE ANTIFREEZE CONTAINER LABEL).

Use only low-mineral drinking water or distilled water as a part of the antifreeze solution. Water that is high in mineral content or salt may be harmful to the aluminum engine.

The factory provides a 50/50 solution of antifreeze and distilled water in this motorcycle. This coolant solution is recommended for most operating temperatures and provides good corrosion protection. A higher concentration of antifreeze decreases the cooling system performance and is recommended only when additional protection against freezing is needed. A concentration of less than 40/60 (40% antifreeze) will not provide proper corrosion protection.

During freezing temperatures, check the cooling system frequently and add higher concentrations of antifreeze (up to a maximum of 60% antifreeze) if required.

## Inspection

Remove the left side cover (page 42 ).

Check the coolant level in the reserve tank while the engine is at normal operating temperature. It should be between the UPPER (1) and LOWER (2) level marks. If the coolant level begins to reach the LOWER level mark (2), add coolant to the UPPER level mark (1). If the reserve tank is empty, or if coolant loss is excessive, check for leaks and see your authorized Honda dealer for repair.

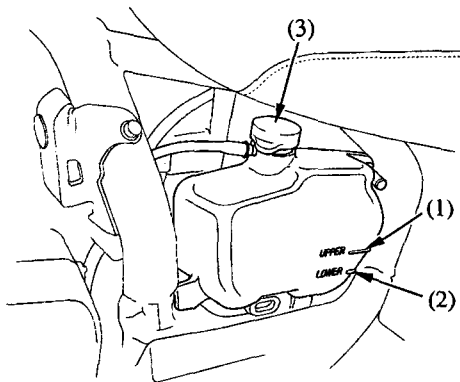
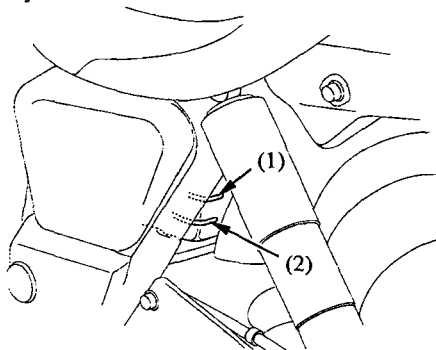

- (1) UPPER level mark
- (2) LOWER level mark
- (3) Reserve tank cap

## FUEL

### Manual Fuel Valve

The manual fuel valve (1) is under the left side of the fuel tank in the left side cover. Set it to ON for normal operation or RES when you start to run out of the main fuel supply. The OFF setting is only for long term storage or servicing of fuel system components.

### Automatic Fuel ON-OFF

With the fuel valve set to ON (or RES) fuel flows to the carburetors only when the engine is being started or is running. A diaphragm shuts off fuel flow when the engine is turned off.

### Reserve Fuel

When the main fuel supply is gone, turn the fuel valve to RES. Refill the tank as soon as possible after switching to RES, then switch the valve back to ON.

The reserve fuel supply is:

4.3 l (1.14 US gal , 0.95 Imp gal)

Remember to check that the fuel valve is in the ON position each time you refuel. If the valve is left in the RES position, you may run out of fuel with no reserve.

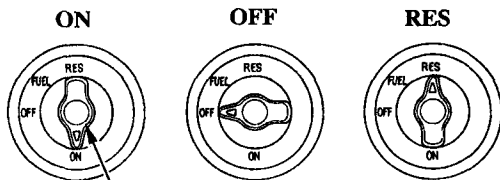

(1)

(1) Fuel valve

## Fuel Tank

The fuel tank capacity, including reserve, is:

20.0 l (5.28 US gal , 4.40 Imp gal)

To open the fuel fill cap (1), insert the ignition key (2) and turn it clockwise. The cap is hinged and will lift up.

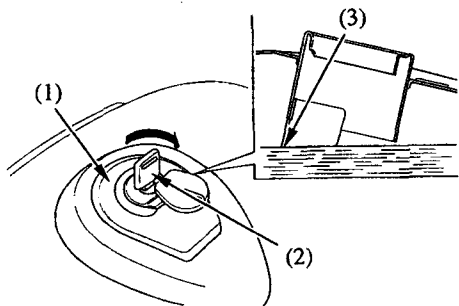

(1) Fuel fill cap

(2) Ignition key

(3) Filler neck

Do not overfill the tank. There should be no fuel in the filler neck (3).

After refueling, to close the fuel fill cap, push the cap into the filler neck until it snaps closed and locks. Remove the key.

## **⚠ WARNING**

Gasoline is highly flammable and explosive. You can be burned or seriously injured when handling fuel.

- Stop the engine and keep heat, sparks, and flame away.
- Handle fuel only outdoors.
- Wipe up spills immediately.

Your engine is designed to use any gasoline that has a pump octane number of 86 or higher. Gasoline pumps at service stations normally display the pump octane number.

We recommend that you use unleaded fuel because it produces fewer engine and spark plug deposits and extends the life of exhaust system components.

Never use stale or contaminated gasoline or an oil/gasoline mixture. Avoid getting dirt, dust or water in the fuel tank. Use of a lower octane gasoline can cause persistent "pinging" or heavy "spark knock" (a metallic rapping noise) which, if severe, can lead to engine damage.

#### **NOTICE**

If "spark knock" or "pinging" occurs at a steady engine speed under normal load, change brands of gasoline. If spark knock or pinging persists, consult your authorized Honda dealer. Failure to do so is considered misuse, and damage caused by misuse is not covered by Honda's Limited Warranty.

Occasionally you may experience light spark knock while operating under heavy loads. This is no cause for concern, it simply means your engine is operating efficiently.

## **Oxygenated Fuels**

Some conventional gasolines are being blended with alcohol or an ether compound. These gasolines are collectively referred to as oxygenated fuels. To meet clean air standards, some areas of the United States and Canada use oxygenated fuels to help reduce emissions.

If you use an oxygenated fuel, be sure it is unleaded and meets the minimum octane rating requirement.

Before using an oxygenated fuel, try to confirm the fuel's contents. Some states/provinces require this information to be posted on the pump. The following are the EPA (The U.S. Environmental Protection Agency) approved percentages of oxygenates:

**ETHANOL** (ethyl or grain alcohol) 10% by Volume

You may use gasoline containing up to 10% ethanol by volume. Gasoline containing ethanol may be marketed under the name "Gasohol".

**MTBE** (Methyl Tertiary Butyl Ether) 15% by Volume

You may use gasoline containing up to 15% MTBE by volume.

**METHANOL** (methyl or wood alcohol) 5% by Volume

You may use gasoline containing up to 5% methanol by volume as long as it also contains cosolvents and corrosion inhibitors to protect the fuel system.

Gasoline containing more than 5% methanol by volume may cause starting and/or performance problems. It may also damage metal, rubber, and plastic parts of your fuel system.

If you notice any undesirable operating symptoms, try another service station or switch to another brand of gasoline.

Fuel system damage or performance problems resulting from the use of an oxygenated fuel containing more than the percentages of oxygenates mentioned above are not covered under warranty.

## ENGINE OIL

### Engine Oil Level Check

Check the engine oil level each day before operating the motorcycle.

#### NOTICE

Running the engine with insufficient oil pressure may cause serious engine damage.

#### To check the oil level:

1. Start the engine and let it idle for a few minutes. Make sure the low oil pressure indicator goes off. If the indicator remains on, stop the engine immediately.
2. Stop the engine and hold the motorcycle in an upright position on firm, level ground.
3. After a few minutes, remove the dipstick (1), wipe it clean, and reinsert the dipstick without screwing it in. Remove the dipstick. The oil level should be between the upper (2) and lower (3) marks on the dipstick.
4. If required, remove the oil filler cap (4) and add the specified oil (page 69) up to the upper level mark. Do not overfill.

5. Reinstall the dipstick and oil filler cap. Check for oil leaks.

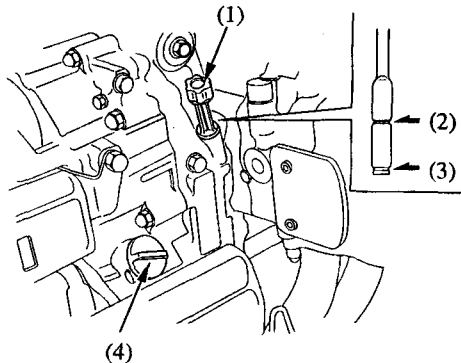

- (1) Dipstick  
(2) Upper level mark

- (3) Lower level mark  
(4) Oil filler cap

## FINAL DRIVE OIL

### Oil Level Check

Check the final drive oil level when specified by the maintenance schedule (page 64 ).

1. Hold the motorcycle upright on firm level ground.
2. Remove the oil filler cap (1).
3. Check that the oil level reaches the lower edge of the oil filler hole (2).

If the level is low, check for leaks. Pour fresh oil through the oil filler hole until it reaches the lower edge of the opening.

**Recommended Oil: HYPOID GEAR OIL  
SAE 80**

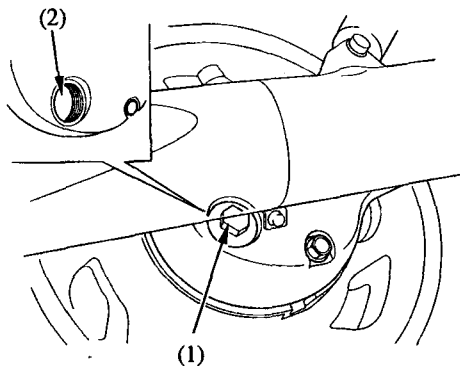

- (1) Oil filler cap  
(2) Oil filler hole

## TIRES

To safely operate your motorcycle, your tires must be the proper type and size, in good condition with adequate tread, and correctly inflated for the load you are carrying. The following pages give more detailed information on how and when to check your air pressure, how to inspect your tires for damage, and what to do when your tires need to be repaired or replaced.

### **WARNING**

Using tires that are excessively worn or improperly inflated can cause a crash in which you can be seriously hurt or killed.

Follow all instructions in this owner's manual regarding tire inflation and maintenance.

## Air Pressure

Keeping your tires properly inflated provides the best combination of handling, tread life and riding comfort. Underinflated tires wear unevenly, adversely affect handling, and are more likely to fail from being overheated. Overinflated tires make your motorcycle ride more harshly, are more prone to damage from road hazards, and wear unevenly.

We recommend that you visually check your tires before every ride and use a gauge to measure air pressure at least once a month or any time you think the tires might be low. Tubeless tires have some self-sealing ability if they are punctured. However, because leakage is often very slow, you should look closely for punctures whenever a tire is not fully inflated.

Always check air pressure when your tires are “cold” — when the motorcycle has been parked for at least three hours. If you check air pressure when your tires are “warm” — when the motorcycle has been ridden for even a few miles — the readings will be higher than if the tires were “cold”. This is normal, so do not let air out of the tires to match the recommended cold air pressures given below. If you do, the tires will be underinflated.

The recommended “cold” tire pressures are:

Front	225 kPa (2.25 kgf/cm <sup>2</sup> , 33 psi)
Rear	225 kPa (2.25 kgf/cm <sup>2</sup> , 33 psi) with less than 90 kg (200 lbs) of added weight
	250 kPa (2.50 kgf/cm <sup>2</sup> , 36 psi) with more than 90 kg (200 lbs) of added weight

(Added weight includes the weight of the rider, passenger, all cargo and all accessories.)

### Inspection

Whenever you check the tire pressures, you should also examine the tire treads and sidewalls for wear, damage, and foreign objects:

Look for:

- Bumps or bulges in the side of the tire or the tread. Replace the tire if you find any bumps or bulges.
- Cuts, splits or cracks in the tire. Replace the tire if you can see fabric or cord.
- Excessive tread wear.

Also, if you hit a pothole or hard object, pull to the side of the road as soon as you safely can and carefully inspect the tires for damage.

## Tread Wear

For the best performance, you should replace a tire before the tread depth at the center reaches 1.5 mm (0.06 in.) for the front tire, and 2.0 mm (0.08 in.) for the rear tire. If the wear indicators (1) are visible, replace the tire immediately as it is no longer safe.

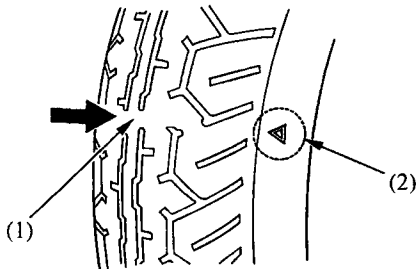

- (1) Wear indicator
- (2) Wear indicator location mark

## **Tire Repair**

If a tire is punctured or damaged, you should replace it, not repair it. As discussed below, a tire that is repaired, either temporarily or permanently, will have lower speed and performance limits than a new tire.

A temporary repair, such as an external tubeless tire plug, may not be safe for normal speeds and riding conditions. If a temporary or emergency repair is made to a tire, you should ride slowly and cautiously to a dealer and have the tire replaced. If possible, you should not carry a passenger or cargo until a new tire is installed.

Even if a tire is professionally repaired with a permanent internal patch plug, it will not be as good as a new tire. You should not exceed 50 mph (80 km/h) for the first 24 hours, or 80 mph (130 km/h) at any time thereafter. In addition, you may not be able to safely carry as much weight as with a new tire. Therefore, we strongly recommend that you replace a damaged tire. If you choose to have a tire repaired, be sure the wheel is balanced before you ride.

## Tire Replacement

The tires that came on your motorcycle were designed to match the performance capabilities of your motorcycle and provide the best combination of handling, braking, durability and comfort.

### **WARNING**

Installing improper tires on your motorcycle can affect handling and stability. This can cause a crash in which you can be seriously hurt or killed.

Always use the size and type of tires recommended in this owner's manual.

The recommended tires for your motorcycle are:

Front: 150/80 R17 72H  
DUNLOP D206F

Rear: 180/70 R16 77H  
DUNLOP D206

Whenever you replace a tire, use one that is equivalent to the original and be sure the wheel is balanced after the new tire is installed.

### **Important Safety Reminders**

- Do not install a tube inside a tubeless tire on this motorcycle. Excessive heat build-up can cause the tube to burst.
- Use only tubeless tires on this motorcycle. The rims are designed for tubeless tires, and during hard acceleration or braking, a tube-type tire could slip on the rim and cause the tire to rapidly deflate.

## ESSENTIAL INDIVIDUAL COMPONENTS

### IGNITION SWITCH

The ignition switch (1) is located under the right side of fuel tank.

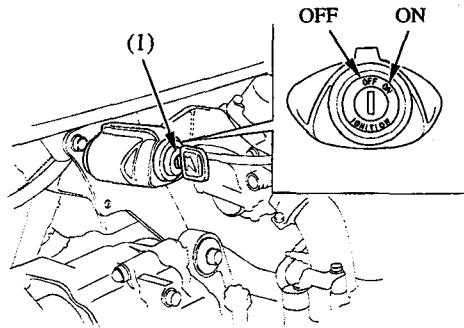





(1) Ignition switch

Key Position	Function	Key Removal
OFF	Engine and lights cannot be operated.	Key can be removed
ON	Headlight, taillight and instrument lights are on and other lights can be operated. Engine can be started.	Key cannot be removed

## RIGHT HANDLEBAR CONTROLS

### Engine Stop Switch

The engine stop switch (1) is next to the throttle grip. When the switch is in the  (RUN) position, the engine will operate. When the switch is in the  (OFF) position, the engine will not operate. This switch is intended primarily as a safety or emergency switch and should normally remain in the  (RUN) position.

If your motorcycle is stopped with the ignition switch ON and the engine stop switch  (OFF), the headlight and taillight will still be on, resulting in battery discharge.

### Starter Button

The starter button (2) is below the engine stop switch (1).

When the starter button is pressed, the starter motor will crank the engine; the headlight will automatically go out, but the taillight will stay on.

The starter motor will not operate when the starter button is pressed if the engine stop switch is in the  (OFF) position.

See pages 48 – 49 for “Starting Procedure.”

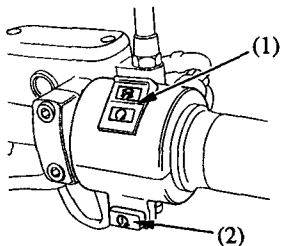



- (1) Engine stop switch
- (2) Starter button



## LEFT HANDLEBAR CONTROLS

The three controls next to the left handlebar grip are:

### Headlight Dimmer Switch (1)

Select  (HI) for high beam,  (LO) for low beam.

### Turn Signal Switch (2)

Move to  (L) to signal a left turn,  (R) to signal a right turn. Press to turn signal off.

### Horn Button (3)

Press the button to sound the horn.

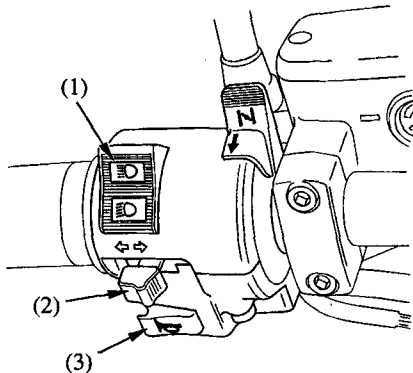

- (1) Headlight dimmer switch
- (2) Turn signal switch
- (3) Horn button

## FEATURES (Not required for operation)

### STEERING LOCK

The steering lock (1) is on the steering stem.  
Turn the handlebar all the way to the left and  
insert the key into lock, turn the key 180°  
clockwise and remove it.

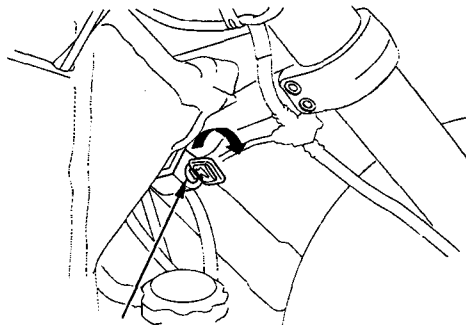
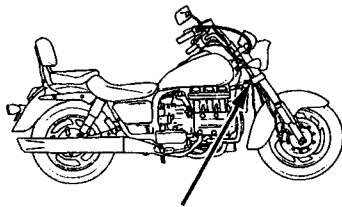

(1)

(1) Steering lock

## SEAT

To remove the seat (1), insert the ignition key into the seat lock (2) and turn it clockwise. Remove the seat by pulling up and forward.

To install the seat, insert the prong (3) into the seat stay under the rear seat. Push the front of the seat down to lock the seat.

Be sure to securely lock the seat after reinstalling it.

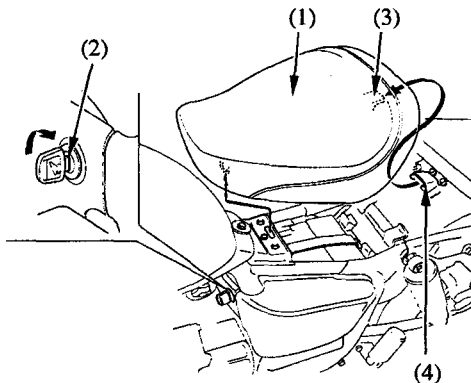

(1) Seat  
(2) Seat lock

(3) Prong  
(4) Seat stay

## HELMET HOLDER

The helmet holder is located under the seat. The helmet holder is designed to secure your helmet and your passenger's helmet while parked. Do not operate the motorcycle with a helmet attached to the holder.

To use the helmet holder, remove the seat (page 39 ).

Route the helmet holder cable (1) through the helmet D-ring (2) and hook the loops of the holder cable onto the helmet holder (3).

Install the seat.

When the helmet holder is not used, attach one end of the holder cable to the holder with the other end routed under the rubber band as shown.

If you must carry an extra helmet while riding, use a commercially available elastic cord, strap or net to secure the helmet to the seat.

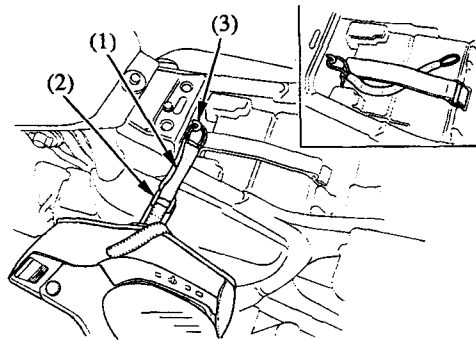

- (1) Helmet holder cable      (3) Holder hook  
(2) D-ring

## OWNER'S MANUAL STORAGE

The owner's manual (and other documents) should be stored in the plastic bag (1) in the owner's manual storage compartment (2) under the seat.

When washing your motorcycle, be careful not to flood this area with water.

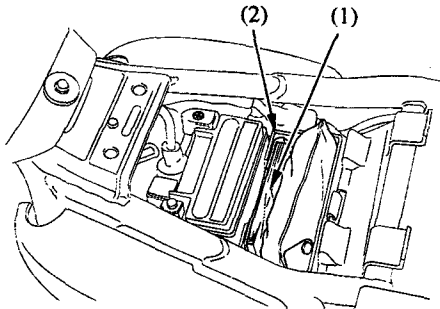

- (1) Owner's manual storage bag
- (2) Owner's manual storage compartment

### To access the compartment:

1. Remove the seat (page 39).
2. Remove the rubber band (3) and battery cover(4).

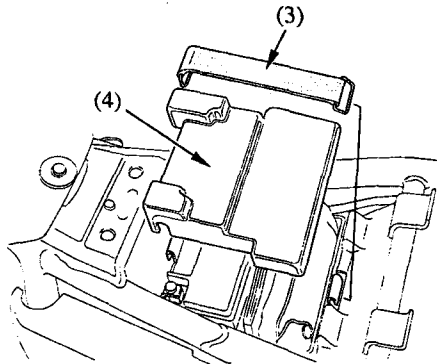

- (3) Rubber band
- (4) Battery cover

## SIDE COVER

The right side cover must be removed for fuse maintenance. The left side cover must be removed to add the coolant.

### NOTICE

Failure to use extreme care removing or installing the side covers may damage the side cover hooks.

#### Removal:

1. Carefully release the grommet from the prong (2) on the frame by pulling the rear of the side cover out toward you.
2. Then release the tab (3) from the grommet on the frame by pulling the bottom of the side cover in the same direction.
3. Remove the side cover by carefully sliding it to the rear until the front hook (4) is clear of the hole in the frame.

#### Installation:

1. Insert the hook (4) into the frame hole.
2. Insert the tab (3) and prong (2) into the grommets.

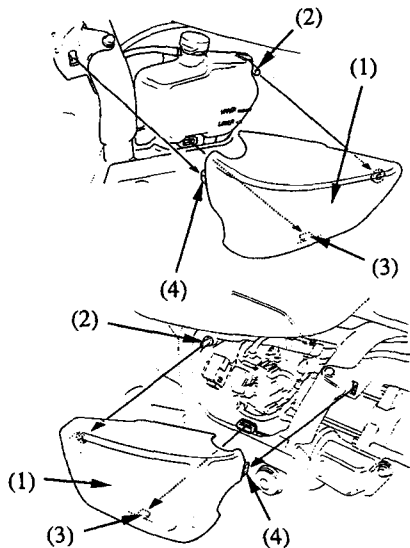

- (1) Side cover  
(2) Prong

- (3) Tab  
(4) Hook

## ACCESSORY (ACC) TERMINAL

For your convenience, your motorcycle is equipped with an accessory terminal, located behind the right side cover. The terminal provides 12V DC power for electrical accessories. A maximum of 60 watts (5 amps) may be connected to the terminal. Before installing any accessory, read Accessories and Modifications, page 7 .

If you install any electrical accessories, check the battery frequently to determine the state of charge. Higher current demands may blow a fuse or discharge the battery. For more information, see Battery, page 91 , and Fuses, page 96 .

Connect accessory electrical leads securely, and keep them insulated, away from hot parts and sharp edges.

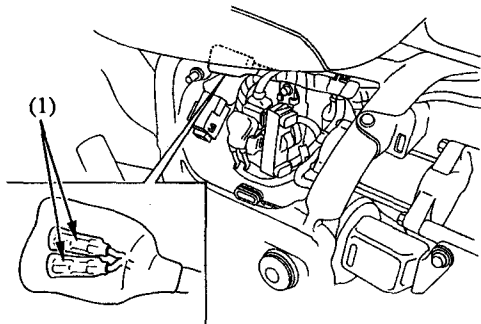

(1) Accessory (ACC) terminal

Positive (+) terminal lead: light green and red

Negative (-) terminal lead: green

## SADDLEBAGS (GL1500CT only)

The saddlebags (1) are for light weight items.

Cargo in each saddlebags should not exceed:

9.0 kg (20.0 lbs)

### To open the saddlebags:

Insert the ignition key (2) into the lid lock (3) and turn it counterclockwise.

To lock the saddlebags, close the lid and turn the ignition key clockwise.

Make sure the lids are locked.

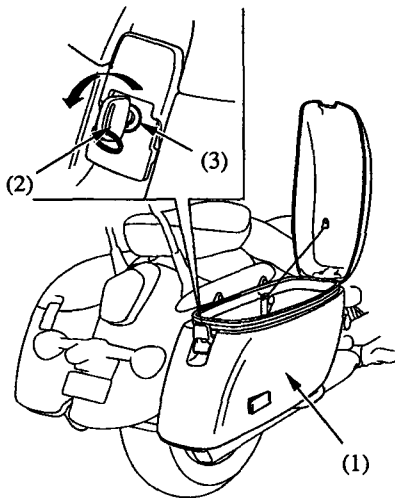

(1) Saddlebag

(3) Lid lock

(2) Ignition key

## OPERATION

### PRE-RIDE INSPECTION

For your safety, it is very important to take a few moments before each ride to walk around your motorcycle and check its condition. If you detect any problem, be sure you take care of it, or have it corrected by your Honda dealer.

### **WARNING**

Improperly maintaining this motorcycle or failing to correct a problem before riding can cause a crash in which you can be seriously hurt or killed.

Always perform a pre-ride inspection before every ride and correct any problems.

Check the following items before you get on the motorcycle:

- **Tires** If a tire looks low, check the air pressure with a gauge. Also look for signs of damage or excessive wear (page 29 ).
- **Leaks** Look for signs of leaking fluids under the motorcycle.
- **Cables, etc.** Check for loose cables and other parts, and anything that appears abnormal.

Check these items after you get on the motorcycle:

- **Throttle** Rotate the throttle to check that it moves smoothly without binding.
- **Brakes** Pull the brake lever and press on the brake pedal to check that they operate normally.

- **Indicators** Turn the ignition on and check for normal operation of the indicators.
- **Lights** Make sure the brake light, taillight and other lights are working properly.

Remember, be sure to take care of any problem you find, or have your dealer correct it, before you ride.

## STARTING THE ENGINE

Always follow the proper starting procedure described below.

This motorcycle is equipped with a side stand ignition cut-off system. The engine cannot be started if the side stand is down, unless the transmission is in neutral. If the side stand is up, the engine can be started in neutral or in gear with the clutch lever pulled in. After starting with the side stand down, the engine will stop if the transmission is put in gear before raising the side stand.

Your motorcycle's exhaust contains poisonous carbon monoxide gas. High levels of carbon monoxide can collect rapidly in enclosed areas such as a garage. Do not run the engine with the garage door closed. Even with the door open, run the engine only long enough to move your motorcycle out of the garage.

Do not use the electric starter for more than 5 seconds at a time. Release the starter button for approximately 10 seconds before pressing it again.

### Preparation

Before starting, insert the key, turn the ignition switch ON and confirm the following:

- The transmission is in NEUTRAL (neutral indicator light ON).
- The engine stop switch is at  $\odot$  (RUN).
- The low oil pressure indicator is ON.
- The fuel valve is ON.

The low oil pressure indicator should go off a few seconds after the engine starts. If the light stays on, stop the engine immediately and check the engine oil level.

### NOTICE

Operating the engine with insufficient oil pressure can cause serious engine damage.

## Starting Procedure

To restart a warm engine, follow the procedure for "High Air Temperature".

### Normal Air Temperature

10°—35°C (50°—95°F)

1. Pull the choke lever (1) back all the way to Fully ON (A), if the engine is cold.
2. Start the engine, leaving the throttle closed.

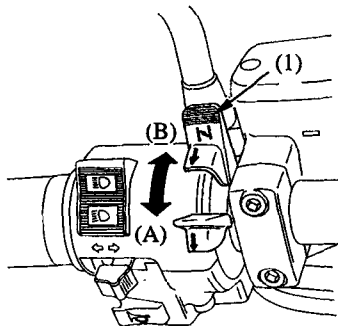

(1) Choke lever

(A) Fully ON

(B) Fully OFF

Do not open the throttle when starting the engine with the choke ON. This will lean the mixture, resulting in hard starting.

### **NOTICE**

Operating the engine with insufficient oil pressure can cause serious engine damage.

3. Immediately after the engine starts, operate the choke lever (1) to keep fast idle at:  
1,500—2,000 rpm
4. About a half minute after the engine starts, push the choke lever (1) forward all the way to Fully OFF (B).
5. If idling is unstable, open the throttle slightly.

### High Air Temperature

35°C (95°F) or above

1. Do not use the choke.
2. Open the throttle slightly.
3. Start the engine.

### Low Air Temperature

10°C (50°F) or below

1. Follow steps 1–2 under “Normal Air Temperature”.
2. When engine rpm begins to pick up, operate the choke lever to keep fast idle at :  
1,500–2,000 rpm
3. Continue warming up the engine until it runs smoothly and responds to the throttle when the choke lever (1) is at Fully OFF (B).

### **NOTICE**

Extended use of the choke may impair piston and cylinder wall lubrication.

Snapping the throttle or fast idling for more than about 5 minutes at normal air temperature may cause exhaust pipe discoloration.

### **Flooded Engine**

If the engine fails to start after repeated attempts, it may be flooded with excess fuel. To clear a flooded engine, leave the engine stop switch on  $\odot$  (RUN) and push the choke lever forward to Fully OFF (B). Open the throttle fully and crank the engine for 5 seconds. If the engine starts, quickly close the throttle, then open it slightly if idling is unstable. If the engine does not start, wait 10 seconds, then follow the "High Air Temperature" Starting Procedure (page 49 ).

### **Ignition Cut Off**

Your motorcycle is designed to automatically stop the engine and fuel pump if the motorcycle is over-turned (a banking sensor cuts off the ignition system). Before restarting the engine, you must turn the ignition switch to the OFF position and then back to ON.

## **BREAK-IN**

During initial break-in, newly machined surfaces will be in contact with each other and these surfaces will wear in quickly. Break-in maintenance at 600 miles (1,000 km) is designed to compensate for this initial minor wear. Timely performance of the break-in maintenance will ensure optimum service life and performance from the engine.

The general rules are as follows:

1. Never lug the engine with full throttle at low engine speeds. This rule is applicable not only during break-in but at all times.
2. Maximum continuous engine speed during the first 600 miles (1,000 km) must not exceed 4,000 rpm.
3. Increase the maximum continuous engine speed by 1,000 rpm between odometer readings of 600 miles (1,000 km) and 1,000 miles (1,600 km). Drive briskly, vary speeds frequently and use full throttle for short bursts only. Do not exceed 5,500 rpm.

4. Upon reaching an odometer reading of 1,000 miles (1,600 km), you can subject the motorcycle to full throttle operation. However, do not exceed 6,500 rpm —indicated by the beginning of the tachometer red zone. (Do not let the tachometer needle enter the red zone.)

## SHIFTING

Review Motorcycle Safety (pages 1 – 10 ) before you ride.

Proper shifting will provide better fuel economy. When changing gears under normal conditions, use these recommended shift points:

### Shifting Up:

From 1st to 2nd:	12 mph (20 km/h)
From 2nd to 3rd:	19 mph (30 km/h)
From 3rd to 4th:	25 mph (40 km/h)
From 4th to 5th:	31 mph (50 km/h)

### Shifting Down:

From 5th to 4th:	22 mph (35 km/h)
From 4th to 3rd:	16 mph (25 km/h)

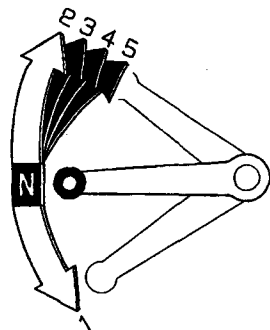

Shifting pattern

Pull in the clutch lever when speed drops below 9 mph (15 km/h), when engine roughness is evident, or when engine stalling is imminent; shift down to 1st gear for acceleration.

To shift properly, pull the clutch lever and close the throttle. Improper shifting may damage the engine and drive train.

Downshifting allows you to use engine braking and lower gearing to decelerate, but downshifting when engine speed is near its allowable maximum may over-rev the engine and cause possible damage.

The battery will not be charged while the engine speed is near idle speed. Avoid idling for prolonged periods.

Do not tow the motorcycle or coast for long distances while the engine is off. The transmission will not be properly lubricated and damage may result.

## **BRAKING**

For normal braking, apply both the brake pedal and lever while down-shifting to match your road speed. For maximum braking, close the throttle and firmly apply the pedal and lever; pull in the clutch lever before coming to a complete stop to prevent stalling the engine.

### **Important Safety Reminders:**

- Independent operation of only the brake lever or brake pedal reduces stopping performance.
- Extreme application of the brake controls may cause wheel lock, reducing control of the motorcycle.
- When possible, reduce speed or brake before entering a turn; closing the throttle or braking in mid-turn may cause wheel slip. Wheel slip will reduce control of the motorcycle.

- When riding in wet or rainy conditions, or on loose surfaces, the ability to maneuver and stop will be reduced. All of your actions should be smooth under these conditions. Rapid acceleration, braking or turning may cause loss of control. For your safety, exercise extreme caution when braking, accelerating or turning.
- When descending a long, steep grade, use engine compression braking by down-shifting, with intermittent use of both brakes. Continuous brake application can overheat the brakes and reduce their effectiveness.
- Riding with your foot resting on the brake pedal or your hand on the brake lever may actuate the brakelight, giving a false indication to other drivers. It may also overheat the brakes, reducing effectiveness.

## **HIGH ALTITUDE RIDING**

When operating this motorcycle at high altitude, the air-fuel mixture becomes overly rich. Above 6,500 feet (2,000 m), driveability and performance may be reduced and fuel consumption increased. The carburetors can be modified to compensate for this high altitude richness.

However, the carburetors must be returned to standard factory specifications when lower altitude riding is desired. See your authorized Honda dealer for high altitude modification.

### **NOTICE**

Sustained operation at altitudes below 5,000 feet (1,500 m) with high altitude carburetor modifications may cause engine overheating and damage.

## **PARKING**

1. After stopping the motorcycle, shift the transmission into neutral, turn the ignition switch OFF, turn the fuel valve OFF, turn the handlebar all the way to the left and remove the key.
2. Use the side stand to support the motorcycle while parked.

Park the motorcycle on firm, level ground to prevent it from falling over.

If you must park on a slight incline, aim the front of the motorcycle uphill to reduce the possibility of rolling off the side stand or overturning.

3. Lock the steering to help prevent theft (page 38 ).

## ANTI-THEFT TIPS

1. Always lock the steering and never leave the key in the ignition switch.

This sounds simple but people do forget.

2. Be sure the registration information for your motorcycle is accurate and current.

3. Park your motorcycle in a locked garage whenever possible.

4. Use an additional anti-theft device of good quality.

5. Put your name, address and phone number in this Owner's Manual and keep it with your motorcycle at all times. Many times stolen motorcycles are identified by information in the Owner's Manuals that are still with them.

NAME: \_\_\_\_\_

ADDRESS: \_\_\_\_\_

\_\_\_\_\_

\_\_\_\_\_

PHONE NO: \_\_\_\_\_

## MAINTENANCE

### THE IMPORTANCE OF MAINTENANCE

A well-maintained motorcycle is essential for safe, economical and trouble-free riding. It will also help reduce air pollution.

To help you properly care for your motorcycle, the following pages include a Maintenance Schedule and a Maintenance Record for regularly scheduled maintenance.

These instructions are based on the assumption that the motorcycle will be used exclusively for its designed purpose. Sustained high speed operation or operation in unusually wet or dusty conditions will require more frequent service than specified in the Maintenance Schedule. Consult your authorized Honda dealer for recommendations applicable to your individual needs and use.

If your motorcycle overturns or becomes involved in a crash, be sure your Honda dealer inspects all major parts, even if you are able to make some repairs.

## **⚠ WARNING**

Improperly maintaining this motorcycle or failing to correct a problem before you ride can cause a crash in which you can be seriously hurt or killed.

Always follow the inspection and maintenance recommendations and schedules in this owner's manual.

## **MAINTENANCE SAFETY**

This section includes instructions on some important maintenance tasks. You can perform some of these tasks with the tools provided — if you have basic mechanical skills.

Other tasks that are more difficult and require special tools are best performed by professionals. Removing the wheels should normally be handled only by a Honda technician or other qualified mechanic; instructions are included in this manual only to assist in emergency service.

Some of the most important safety precautions follow. However, we cannot warn you of every conceivable hazard that can arise in performing maintenance. Only you can decide whether or not you should perform a given task.

## **⚠ WARNING**

Failure to properly follow maintenance instructions and precautions can cause you to be seriously hurt or killed.

Always follow the procedures and precautions in this owner's manual.

## SAFETY PRECAUTIONS

- Make sure the engine is off before you begin any maintenance or repairs. This will help eliminate several potential hazards:
  - \* **Carbon monoxide poisoning from engine exhaust.**  
Be sure there is adequate ventilation whenever you operate the engine.
  - \* **Burns from hot parts.**  
Let the engine and exhaust system cool before touching.
  - \* **Injury from moving parts.**  
Do not run the engine unless instructed to do so.
- Read the instructions before you begin, and make sure you have the tools and skills required.
- To help prevent the motorcycle from falling over, park it on a firm, level surface, using the side stand or a maintenance stand to provide support.

- To reduce the possibility of a fire or explosion, be careful when working around gasoline or batteries. Use only nonflammable solvent, not gasoline, to clean parts. Keep cigarettes, sparks and flames away from the battery and all fuel-related parts.

Remember that your authorized Honda dealer knows your motorcycle best and is fully equipped to maintain and repair it.

To ensure the best quality and reliability, use only new genuine Honda parts or their equivalents for repair and replacement.

If you have the tools and skills required for additional maintenance jobs, you can purchase an official Honda Service Manual from your Honda dealer (see page 109).

## EMISSION REQUIREMENTS

The U.S. Environmental Protection Agency, the California Air Resources Board (CARB), and Transport Canada require that your motorcycle comply with applicable exhaust emissions standards during its useful life, when operated and maintained according to the instructions provided, and that motorcycles built after January 1, 1983 comply with applicable noise emission standards (USA only) for one year or 6,000 km (3,730 miles) after the time of sale to the ultimate purchaser, when operated and maintained according to the instructions provided. Compliance with the terms of the Distributor's Warranties for Honda Motorcycle Emission Control Systems is necessary in order to keep the emissions system warranty in effect.

The Vehicle Emission Control Information Label (1) is attached to the inside of the left side cover.

The Vacuum Hose Routing Diagram Label (2) is attached behind the left side cover. (California only)

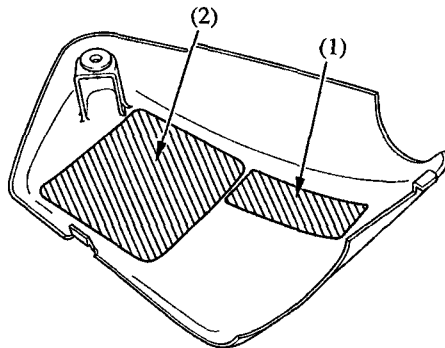

- (1) Vehicle Emission Control Information Label
- (2) Vacuum Hose Routing Diagram Label

## MAINTENANCE SCHEDULE

Perform the Pre-ride Inspection (page 45 ) at each scheduled maintenance period.

Each item on the maintenance schedule requires some mechanical knowledge. Certain items (particularly those marked \* and \*\*) may require more technical information and tools. Consult your authorized Honda Dealer.

- \*: Should be serviced by your authorized Honda dealer, unless the owner has proper tools, service data and is mechanically qualified.  
Refer to official Honda Service Manual.
- \*\* : In the interest of safety, we recommend these items be serviced only by your authorized Honda dealer.

Summary of Maintenance Schedule Notes and Procedures:

- NOTE: (1) At higher odometer readings, repeat at the frequency interval established here.
- (2) Service more frequently when riding in unusually wet or dusty areas.
  - (3) Service more frequently when riding in rain or at full throttle.
  - (4) Replace every 2 years, or at indicated odometer interval, whichever comes first.  
Replacement requires mechanical skill.
  - (5) California type only.

Maintenance Procedures:

- I: Inspect and Clean, Adjust, Lubricate or Replace if necessary
- C: Clean
- A: Adjust
- L: Lubricate
- R: Replace

ITEM	FREQUENCY	NOTE	ODOMETER READING [NOTE (1)]								Refer to page	
			× 1,000 mi	0.6	4	8	12	16	20	24		
			× 1,000 km	1	6.4	12.8	19.2	25.6	32.0	38.4		
E M I S S I O N  R E L A T E D  I T E M S	* FUEL LINE					I		I		I		—
	* THROTTLE OPERATION					I		I		I		76
	* CARBURETOR CHOKE					I		I		I		—
	* AIR CLEANER	NOTE (2)					R				R	—
	CRANKCASE BREATHER	NOTE (3)			C	C	C	C	C	C	C	73
	SPARK PLUG					R		R		R		74
	* VALVE CLEARANCE						I			I		—
	ENGINE OIL					R		R		R		69
	ENGINE OIL FILTER					R		R		R		70
	** TIMING BELT					EVERY 100,000 mi (160,000 km) I						—
	* CARBURETOR SYNCHRONIZATION					I		I		I		—
	* ENGINE IDLE SPEED					I	I	I	I	I	I	77
	RADIATOR COOLANT	NOTE (4)					I		I		R	21
	* COOLING SYSTEM						I		I		I	—
	* SECONDARY AIR SUPPLY SYSTEM						I		I		I	—
* EVAPORATIVE EMISSION CONTROL SYSTEM	NOTE (5)						I			I	—	

ITEM	FREQUENCY	NOTE	ODOMETER READING [NOTE (1)]								Refer to page	
			× 1,000 mi	0.6	4	8	12	16	20	24		
			× 1,000 km	1	6.4	12.8	19.2	25.6	32.0	38.4		
NON-EMISSION RELATED ITEMS	FINAL DRIVE OIL				I			I			R	28, 79
	BRAKE FLUID	NOTE (4)			I	I	R	I	I		R	18
	BRAKE PAD WEAR				I	I	I	I	I		I	80
	BRAKE SYSTEM			I		I		I			I	18, 80
	* BRAKE LIGHT SWITCH					I		I			I	—
	* HEADLIGHT AIM					I		I			I	—
	CLUTCH SYSTEM					I		I			I	—
	CLUTCH FLUID	NOTE (4)				I	I	R	I	I	R	20
	SIDE STAND					I		I			I	82
	* SUSPENSION					I		I			I	—
	* NUTS, BOLTS, FASTENERS				I		I		I		I	—
	** WHEELS /TIRES					I		I			I	—
	** STEERING HEAD BEARINGS				I		I		I		I	—

## MAINTENANCE RECORD

Miles (km)	Performed By	Odometer	Date
600 (1,000)			
4,000 (6,400)			
8,000 (12,800)			
12,000 (19,200)			
16,000 (25,600)			
20,000 (32,000)			
24,000 (38,400)			
28,000 (44,800)			
32,000 (51,200)			
36,000 (57,600)			
40,000 (64,000)			
44,000 (70,400)			
48,000 (76,800)			

- Make sure whoever performs the maintenance completes this record. All scheduled maintenance, including the 600 mile (1,000 km) break-in maintenance, is considered a normal owner operating cost and will be charged for by your dealer.
- Detailed receipts verifying the performance of required maintenance should be retained. These receipts should be transferred with the motorcycle to the new owner if the motorcycle is sold.

## TOOL KIT

The tool kit (1) is in the tool kit compartment (2) under the seat (page 39 ).

Some roadside repairs, minor adjustments and parts replacement can be performed with the tools contained in the kit.

- 10 × 12 mm open end wrench
- 14 × 17 mm open end wrench
- 8 mm open end wrench
- 10 × 12 mm box end wrench
- 14 × 17 mm box end wrench
- 22 mm box end wrench
- 27 mm box end wrench
- 8 mm hex wrench
- 5 mm hex wrench
- 6 mm hex wrench
- Spark plug wrench
- No.2 Phillips screwdriver
- No.2 Screwdriver
- Screwdriver grip
- Pliers
- Pin spanner
- Extension bar
- Tool bag

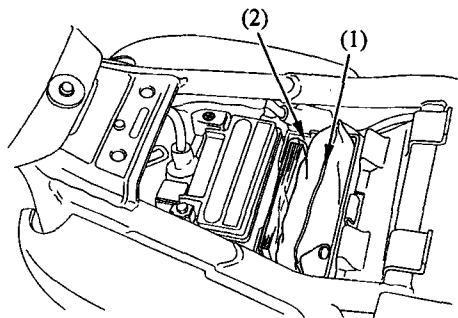

(1) Tool kit

(2) Tool kit compartment

## SERIAL NUMBERS

The frame and engine serial numbers are required when registering your motorcycle. They may also be required by your dealer when ordering replacement parts.

Record the numbers here for your reference.

VIN \_\_\_\_\_

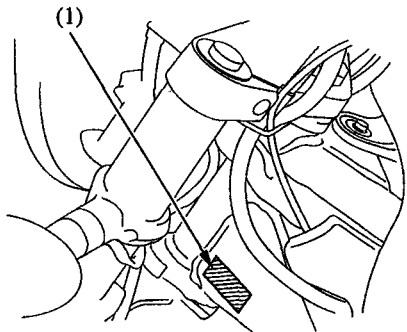

(1) VIN

The VIN, Vehicle Identification Number (1), is on the Safety Certification Label affixed to the left side of the frame near the steering head. The frame number (2) is stamped on the right side of the steering head.

FRAME NO. \_\_\_\_\_

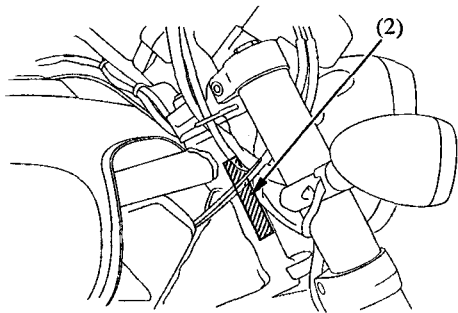

(2) Frame number

The engine number (3) is stamped on the right side of the crankcase.

ENGINE NO. \_\_\_\_\_

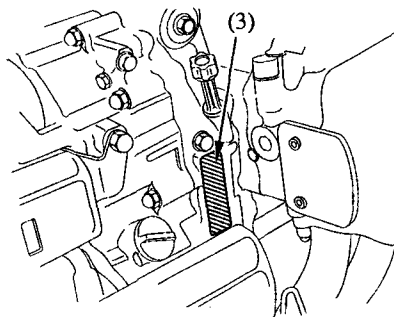

(3) Engine number

### COLOR LABEL

The color label (1) is attached to the frame behind the left side cover.

Remove the left side cover (page 42 ).

It is helpful when ordering replacement parts.

Record the color and code here for your reference.

COLOR \_\_\_\_\_

CODE \_\_\_\_\_

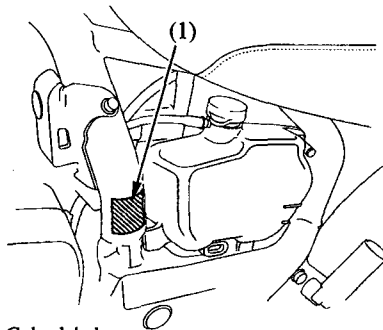

(1) Color label

## ENGINE OIL

Refer to the Safety Precautions on page 60.

### Engine Oil Recommendation:

**USE PRO HONDA GN4 OR HP4  
4-STROKE OIL OR AN EQUIVALENT**

### For Canada

**USE HONDA 4-STROKE OIL OR AN  
EQUIVALENT**

Use only high detergent, premium quality motor oil certified to meet API Service Classification SF or SG.

Motor oils intended for Service SF or SG will show this designation on the container. The use of special oil additives is unnecessary and will only increase operating expenses.

Engine oil is a major factor affecting the performance and service life of the engine. Non-detergent, vegetable or castor-based racing oils are not recommended.

## Recommended Oil Viscosity

### SAE 10W-40

Other viscosities shown in the chart below may be used when the average temperature in your riding area is within the indicated range.

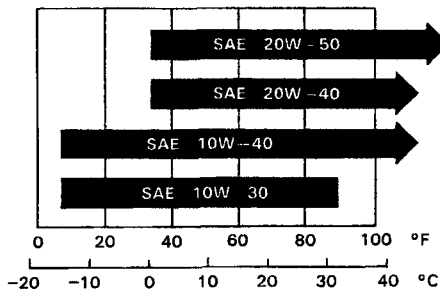

## Engine Oil and Filter

Engine oil quality is the chief factor affecting engine service life. Change the engine oil as specified in the maintenance schedule (page 63 ).

When running in very dusty conditions, oil changes should be performed more frequently than specified in the maintenance schedule.

Please dispose of used engine oil in a manner that is compatible with the environment. We suggest you take it in a sealed container to your local recycling center or service station for reclamation. Do not throw it in the trash or pour it on the ground or down a drain.

Changing the oil filter requires a special oil filter tool and a torque wrench. If you do not have these tools and the necessary skill, we recommend that you have your authorized Honda dealer perform this service.

If a torque wrench is not used for this installation, see your authorized Honda dealer as soon as possible to verify proper assembly.

Change the engine oil with the engine at normal operating temperature and the motorcycle on its side stand to assure complete and rapid draining.

After the engine oil has been drained out, hold the motorcycle upright for 10–15 seconds to assure complete draining, then retighten the drain bolt.

1. To drain the oil, remove the oil filler cap and crankcase drain plug (1) and sealing washer (2).

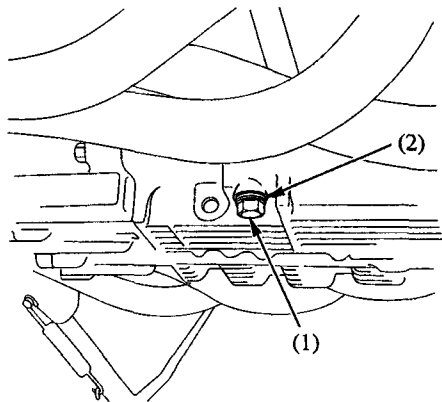

(1) Crankcase drain plug (2) Sealing washer

2. Remove the oil filter (3) with a filter wrench and let the remaining oil drain out. Discard the oil filter.

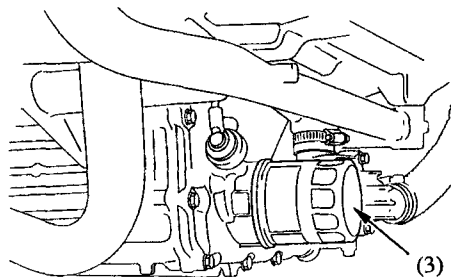

(3) Oil filter

3. Apply a thin coat of engine oil to the new oil filter rubber seal (4).
4. Using a special tool and a torque wrench, install the new oil filter and tighten to a torque of:

10 N·m (1.0 kgf·m , 7 lbf·ft)

Use only the Honda genuine oil filter or a filter of equivalent quality specified for your model. Using the wrong Honda filter or a non-Honda filter which is not of equivalent quality may cause engine damage.

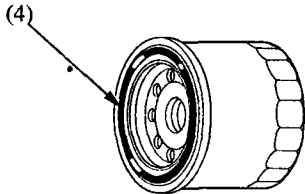

5. Check that the sealing washer on the drain plug is in good condition and install the plug. Replace the sealing washer every other time the oil is changed, or each time if necessary.  
Oil Drain Plug Torque:  
34 N·m (3.5 kgf·m , 25 lbf·ft)
6. Fill the crankcase with the recommended grade oil; approximately:  
3.7 ℓ (3.9 US qt , 3.3 Imp qt)
7. Install the oil filler cap.
8. Start the engine and let it idle for 2–3 minutes.
9. Several minutes after stopping the engine, check that the oil level is at the upper level mark on the dipstick with the motorcycle upright on firm, level ground. Make sure there are no oil leaks.

(4) Oil filter rubber seal

## CRANKCASE BREATHER

Refer to the Safety Precautions on page 60 .

1. Remove the crankcase breather tube plug (1) from the tube and drain deposits into a suitable container.
2. Reinstall the crankcase breather tube plug.

Service more frequently when riding in rain or at full throttle.

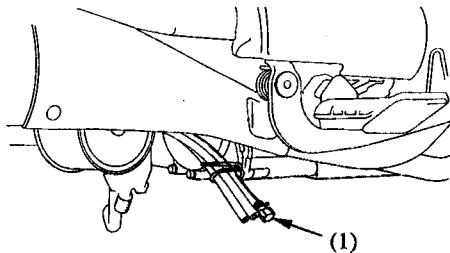

(1) Crankcase breather tube plug

## SPARK PLUGS

Refer to the Safety Precautions on page 60 .

Recommended plugs:

Standard:

DPR7EA-9 (NGK) or  
X22EPR-U9 (NIPPONDENSO)

For cold climate: (Below 5°C, 41°F)  
DPR6EA-9 (NGK) or  
X20EPR-U9 (NIPPONDENSO)

For extended high speed riding:  
DPR8EA-9 (NGK) or  
X24EPR-U9 (NIPPONDENSO)

### NOTICE

Never use a spark plug with an improper heat range. Severe engine damage could result.

1. Disconnect the spark plug caps from the spark plugs.
2. Clean any dirt from around the spark plug bases.

Remove the spark plugs using the spark plug wrench furnished in the tool kit.

3. Discard the spark plugs.
4. Check the new spark plug gap (1) using a wire-type feeler gauge. If adjustment is necessary, bend the side electrode (2) carefully.  
The gap should be:  
0.80-0.90 mm (0.031-0.035 in)

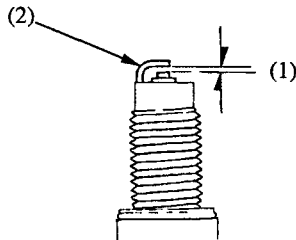

(1) Spark plug gap

(2) Side electrode

5. With the plug washer attached, thread the spark plug in by hand to prevent crossthreading.
6. Tighten a new spark plug 1/2 turn with a spark plug wrench to compress the washer. If you are reusing a plug, it should only take 1/8 - 1/4 turn after the plug seats.

#### NOTICE

The spark plug must be securely tightened. An improperly tightened plug can become very hot and possibly damage the engine.

7. Reinstall the spark plug caps.

## THROTTLE OPERATION

Refer to the Safety Precautions on page 60 .

1. Check for smooth rotation of the throttle grip from the fully open to the fully closed position at all steering positions.
2. Measure the throttle grip free play at the throttle grip flange. The standard free play should be approx:  
2-6 mm (0.08-0.24 in)

To adjust play, loosen the lock nut (1) and turn the adjuster (2).

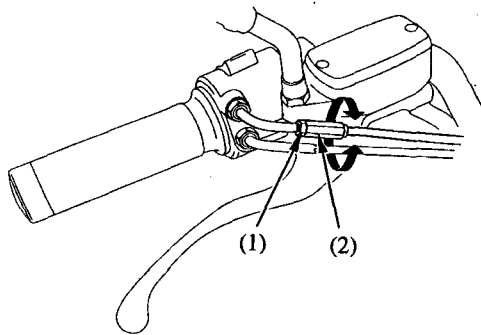

(1) Lock nut

(2) Adjuster

## IDLE SPEED

Refer to the Safety Precautions on page 60 .

The engine must be at normal operating temperature for accurate idle speed adjustment. Ten minutes of stop-and-go riding is sufficient.

Do not attempt to compensate for faults in other systems by adjusting idle speed. See your authorized Honda dealer for regularly scheduled carburetor adjustments, including individual carburetor adjustment and synchronization.

1. Warm up the engine, shift to neutral and place the motorcycle on its stand.
2. Adjust idle speed with the throttle stop screw (1).

Idle speed (in neutral):

$900 \pm 100$  rpm

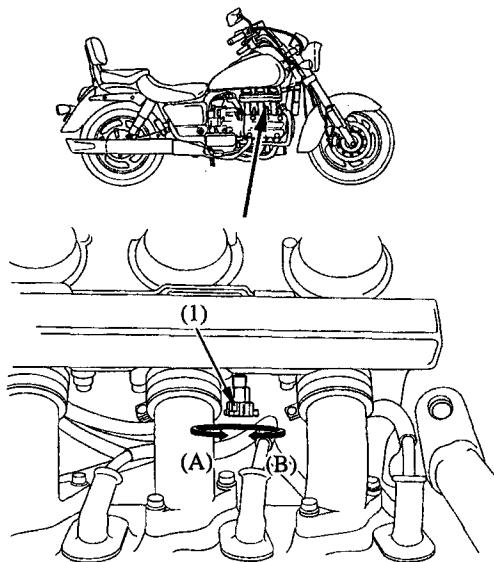

(1) Throttle stop screw

(A) Increase

(B) Decrease

## COOLANT

Refer to the Safety Precautions on page 60.

### Coolant Replacement

Coolant should be replaced by an authorized Honda dealer, unless the owner has proper tools and service data and is mechanically qualified. Refer to an official Honda Service Manual.

Always add coolant to the reserve tank. Do not attempt to add coolant by removing the radiator cap.

## WARNING

Removing the radiator cap while the engine is hot can cause the coolant to spray out, seriously scalding you.

Always let the engine and radiator cool down before removing the radiator cap.

## FINAL DRIVE OIL

Refer to the Safety Precautions on page 60.

Change the oil as specified in the maintenance schedule (page 64 ).

Change the oil with final drive at normal operating temperature and the motorcycle upright on level ground to assure complete and rapid draining.

1. To drain the oil, remove the oil filler cap (1) and drain plug (2).
2. After the oil has completely drained, check that the sealing washer (3) on the drain plug is in good condition and install the drain plug.

Drain Plug Torque:

20 N·m (2.0 kgf·m , 14 lbf·ft)

3. With the motorcycle upright on level ground, fill the final drive with the recommended oil; approximately:  
170 cc (5.7 US oz , 6.0 Imp oz)

4. Make sure the final drive is filled up to the lower edge of the inspection hole (4) with the recommended oil.  
Install the oil filler cap.

**Recommended Oil: HYPOID GEAR OIL  
SAE 80**

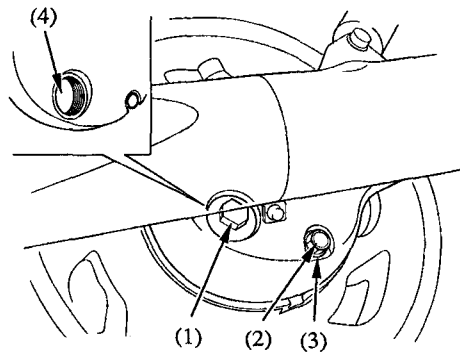

- (1) Oil filler cap  
(2) Oil drain plug

- (3) Sealing washer  
(4) Inspection hole

## BRAKE PAD WEAR

Refer to the Safety Precautions on page 60.

Brake pad wear depends upon the severity of usage, the type of riding, and road conditions. (Generally, the pads will wear faster on wet and dirty roads.)

Inspect the pads at each regular maintenance interval (page 64).

### Front Brake

Check the cutout (1) in each pad.

If either pad is worn to the cutout, replace both pads as a set. See your authorized Honda dealer for this service.

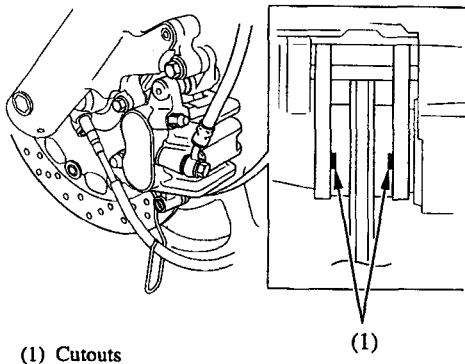

## Rear Brake

Check the cutout (2) in each pad.

If either pad is worn to the cutout, replace both pads as a set. See your authorized Honda dealer for this service.

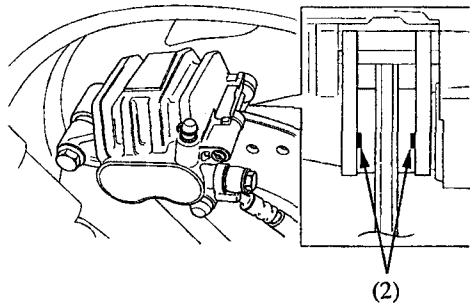

(2) Cutout

## SIDE STAND

Refer to the Safety Precautions on page 60.

Check the side stand system for proper function.

- Check the spring (1) for damage or loss of tension and the side stand assembly for freedom of movement.
- Check the side stand ignition cut-off system:
  1. Sit astride the motorcycle: put the side stand up and the transmission in neutral.
  2. Start the engine and with the clutch lever pulled in, shift the transmission into gear.
  3. Lower the side stand. The engine should stop as you put the side stand down.

If the side stand system does not operate as described, see your authorized Honda dealer for service.

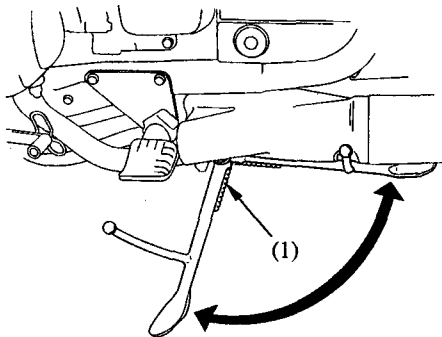

(1) Side stand spring

## WHEEL REMOVAL

Refer to the Safety Precautions on page 60 .

This motorcycle is equipped with a side stand only. Therefore, if front or rear wheel removal is required, it will be necessary to raise the center of the motorcycle with a chain hoist. If none is available, see your authorized Honda dealer for this service.

### Front Wheel Removal

1. Raise the front wheel off the ground by using a chain hoist.
2. Remove the right and left caliper assemblies (1) from the fork legs by removing the fixing bolts (2).

To avoid damage to the brake hose, support the caliper assembly so that it doesn't hang from the hose. Do not twist the brake hose.

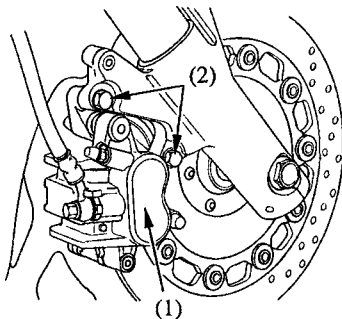

- (1) Caliper assembly  
(2) Fixing bolts

3. Disconnect the speedometer cable (3) from the speedometer gearbox by removing the cable set screw (4).
4. Loosen the right and left axle pinch bolts (5) and remove the axle bolt (6).
5. Remove the front axle (7) and the wheel.

Do not depress the brake lever when the wheel is off the motorcycle. The caliper pistons will be forced out of the cylinders with subsequent loss of brake fluid. If this occurs, servicing of the brake system will be necessary. See your authorized Honda dealer for this service.

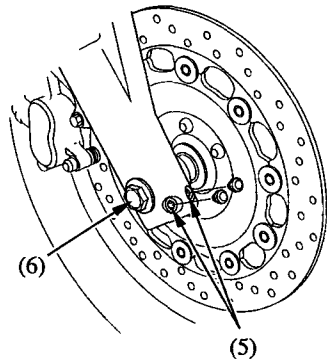
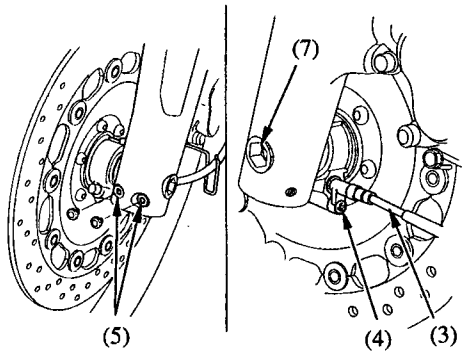

(3) Speedometer cable  
(4) Cable set screw

(5) Axle pinch bolts  
(7) Axle shaft

(5) Axle pinch bolts  
(6) Axle bolt