

# HONDA SHADOW

SA 200

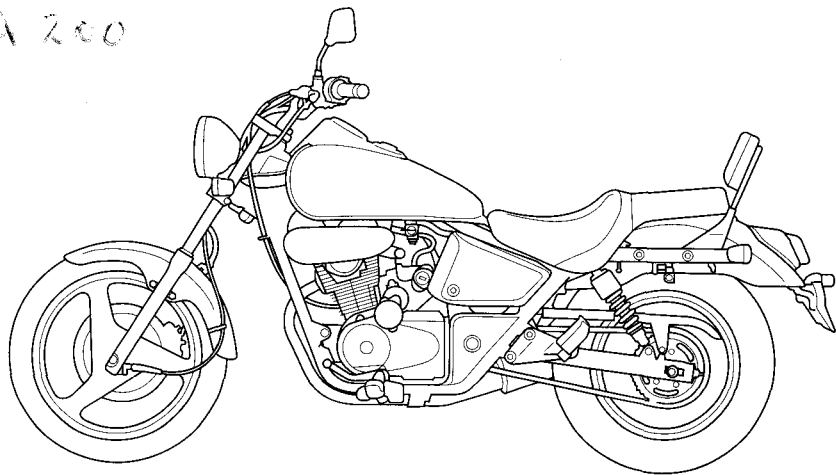

33 KPKA E1 ASH



# OWNER'S MANUAL

## **SHADOW**

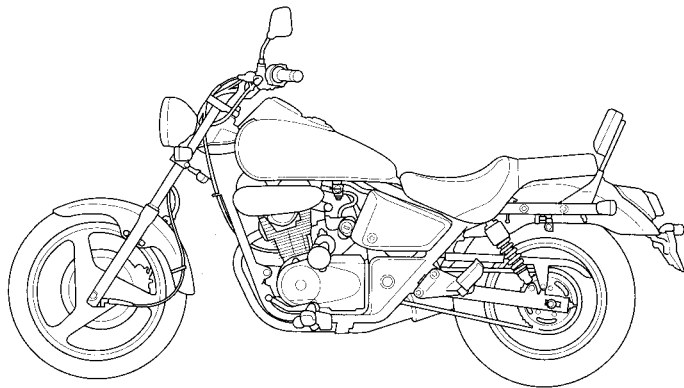

All information in this publication is based on the latest production information available at the time of approval for printing. Honda Motor Co., Ltd. reserves the right to make changes at any time without notice and without incurring any obligation. No part of this publication may be reproduced without written permission.

## **TAMPERING WITH THE NOISE CONTROL SYSTEM IS PROHIBITED**

Owners are warned that the law may prohibit:

(a) The removal or rendering inoperative by any person other than for purposes of maintenance, repair or replacement, of any device or element of design incorporated into any new motorcycle for the purpose of noise control prior to its sale or delivery to the ultimate purchaser or while it is in use:

and

(b) The use of the motorcycle after such device or element of design has been removed or rendered inoperative by any person.

# IMPORTANT NOTICE

- **OPERATOR AND PASSENGER**

This motorcycle is designed to carry the operator and one passenger. Never exceed the maximum weight capacity as shown on the loading and accessories label.

- **ON-ROAD USE**

*This motorcycle is designed to be used only on the road.*

- **READ THIS OWNER'S MANUAL CAREFULLY**

Pay special attention to statements preceded by the following words:

**⚠ WARNING**

**Indicates a strong possibility of severe personal injury or death if instructions are not followed.**

**CAUTION:**

**Indicates a possibility of personal injury or equipment damage if instructions are not followed.**

**NOTE:** Gives helpful information.

This manual should be considered a permanent part of the motorcycle and should remain with the motorcycle when resold.

# WELCOME

The motorcycle presents you a challenge to master the machine, a challenge to adventure. You ride through the wind, linked to the road by a vehicle that responds to your commands as no other does. Unlike an automobile, there is no metal cage around you. Like an airplane, a pre-ride inspection and regular maintenance are essential to your safety. Your reward is freedom.

To meet the challenges safely, and to enjoy the adventure fully, you should become thoroughly familiar with this owner's manual **BEFORE YOU RIDE THE MOTORCYCLE**.

When service is required, remember that your Honda dealer knows your motorcycle best. If you have the required mechanical "know-how" and tools, your dealer can supply you with an official Honda Service Manual to help you perform many maintenance and repair tasks.

Pleasant riding, and thank you for choosing a Honda !

## **PARTS EXCLUDED FROM GUARANTEE**

In case of any worn parts resulting from or of any parts to be replaced after their normal use e.g. nuts, bolts, screws, washers, brake cables, clutch cables, throttle cables, carburetor choke cables, speedometer cables, revolution counter cables, inner tubes, tyres, brake shoes, brake pads, clutch discs, all kinds of seals, gaskets, electric wires and lubricants, light bulbs, fuses, sparkplugs, air cleaner elements, drive chains, front sprocket, back sprocket.

The company does hereby reserve all rights to consider any guarantee for the above mentioned parts worn or damaged during the period of guarantee when required by the customers to compensate for such damages, and/or to verify and search for any reasonable cause for worn parts before taking in account any request.

## **INSTRUCTION FOR USE OF HONDA MOTORCYCLES**

1. To comply with all instructions specified in the User's Guides of all models of Honda motorcycles.
2. To carry out the first and following maintenance according to the specification contained in the tables at the Honda Service Centers or the Honda's authorized dealers.
3. Not to modify any parts unless otherwise specified by the original manufacturing standard and the technical specifications provided by the company.
4. Not to use the product for any purposes other than the normal ones e.g. competition, etc.
5. To use only the authentic spare parts of Honda and the lubricants such as oils or greases specified in the instructions in case of repair or maintenance.
6. Not to carry out any modification if desiring to claim for damages.
7. To show if possible a guarantee book in your own interest.
8. To use if possible only the service of the Honda Services centers.



# OPERATION

## Page

### **1 MOTORCYCLE SAFETY**

- 1 Safe Riding Rules
- 2 Protective Apparel
- 2 Modifications
- 3 Loading and Accessories

### **6 PARTS LOCATION**

- 9 Instruments and Indicators

### **11 MAJOR COMPONENTS**

(Information you need to operate this motorcycle)

- 11 Suspension
- 12 Brakes
- 16 Clutch
- 18 Fuel
- 22 Engine Oil
- 23 Tubeless Tyres

### **26 ESSENTIAL INDIVIDUAL COMPONENTS**

- 26 Ignition Switch

## Page

- 27 Right Handlebar Controls
- 28 Left Handlebar Controls

### **29 FEATURES**

(Not required for operation)

- 29 Steering Lock
- 30 Helmet Holder
- 31 Side Cover
- 32 Document Compartment
- 33 Seat
- 34 Headlight Aim Vertical Adjustment

### **35 OPERATION**

- 35 Pre-ride Inspection
- 36 Starting the Engine
- 39 Running-in
- 40 Riding
- 42 Braking
- 43 Parking
- 43 Anti-theft Tips

# MAINTENANCE

## Page

### **44 MAINTENANCE**

45	Maintenance Schedule
48	Tool Kit
49	Serial Numbers
50	Maintenance Precautions
51	Air Cleaner
52	Crankcase Breather
53	Engine Oil
56	Spark Plugs
58	Throttle Operation
59	Idle Speed
60	Drive Chain
66	Front and Rear Suspension Inspection
66	Side Stand

## Page

67	Brake Pad Wear
69	Wheel Removal
74	Battery
77	Fuse Replacement
79	Stoplight Switch Adjustment
80	Bulb Replacement

### **84 CLEANING**

### **86 STORAGE GUIDE**

86	Storage
88	Removal From Storage

### **89 SPECIFICATIONS**

### **92 CATALYTIC CONVERTER**

# MOTORCYCLE SAFETY

## WARNING

- **Motorcycle riding requires special efforts on your part to ensure your safety. Know these requirements before you ride:**

## SAFE RIDING RULES

1. Always make a pre-ride inspection (page 36) before you start the engine. You may prevent an accident or equipment damage.
2. Many accidents involve inexperienced riders. Most countries require a special motorcycle riding test or license. Make sure you are qualified before you ride. NEVER lend your motorcycle to an inexperienced rider.
3. Many automobile/motorcycle accidents happen because the automobile driver does not “see” the motorcyclist.
  - Make yourself conspicuous to help avoid the accident that wasn’t your fault:
    - Wear bright or reflective clothing.
    - Don’t ride in another motorist’s “blind spot.”
4. Obey all national and local laws and regulations.
  - Excessive speed is a factor in many accidents. Obey the speed limits, and NEVER travel faster than conditions warrant.
  - Signal before you make a turn or lane change. Your size and maneuverability can surprise other motorists.
5. Don’t let other motorists surprise you. Use extra caution at intersections, parking lot entrances and exits, and driveways.
6. Keep both hands on the handlebars and both feet on the footpegs while riding. A passenger should hold on to the motorcycle or the operator with both hands and keep both feet on the passenger footpegs.

## PROTECTIVE APPAREL

1. Most motorcycle accident fatalities are due to head injuries: ALWAYS wear a helmet. You should also wear a face shield or goggles as well as boots, gloves and protective clothing. A passenger needs the same protection.
2. The exhaust system becomes hot during operation, and it remains hot for a while after stopping the engine. Be careful not to touch the exhaust system while it is hot. Wear clothing that fully covers your legs.
3. Do not wear loose clothing which could catch on the control levers, footpegs, drive chain or wheels.

## MODIFICATIONS

### WARNING

- **Modification of the motorcycle, or removal of original equipment, may render the vehicle unsafe or illegal. Obey all national and local equipment regulations.**

## LOADING AND ACCESSORIES

### **⚠ WARNING**

- **To prevent an accident, use extreme care when adding and riding with accessories and cargo. Addition of accessories and cargo can reduce a motorcycle's stability, performance and safe operating speed. Never ride an accessory-equipped motorcycle at speeds above 130 km/h (80 mph). And remember that this 130 km/h (80mph) limit may be reduced by installation of non-Honda accessories, improper loading, worn tyres and overall motorcycle condition, poor road or weather conditions. These general guidelines may help you decide whether or how to equip your motorcycle and how to load it safely.**

### **Loading**

The combined weight of the rider, passenger, cargo and all accessories must not exceed the maximum weight capacity:

126 kg (277 lbs)

1. Keep cargo and accessory weight low and close to the center of the motorcycle. Load weight equally on both sides to minimize imbalance. As weight is located further from the motorcycle's center of gravity, handling is proportionally affected.
2. Adjust tyre pressure (page 23) and rear suspension (page 11) to suit load weight and riding conditions.

3. Vehicle handling and stability can be adversely affected by loose cargo. Recheck cargo security and accessory mounts frequently.
4. Do not attach large or heavy items (such as a sleeping bag or tent) to the handlebars, fork, or fender. Unstable handling or slow steering response may result.

## **Accessories**

Genuine Honda accessories have been specifically designed for and tested on this motorcycle. Because the factory cannot test all other accessories, you are personally responsible for proper selection, installation, and use of non-Honda accessories. Always follow the guidelines under Loading, and these:

1. Carefully inspect the accessory to make sure it does not obscure any lights, reduce ground clearance and banking angle, or limit suspension travel, steering travel or control operation.
2. Large fork-mounted fairings or windshields, or poorly designed or improperly mounted fairings can produce aerodynamic forces that cause unstable handling. Do not install fairings that decrease cooling air flow to the engine.

3. Accessories which alter your riding position by moving hands or feet away from controls may increase reaction time in an emergency.
4. Do not add electrical equipment that will exceed the motorcycle's electrical system capacity. A blown fuse could cause a dangerous loss of lights or engine power.
5. This motorcycle was not designed to pull a sidecar or trailer. Handling may be seriously impaired if so equipped.

## PARTS LOCATION

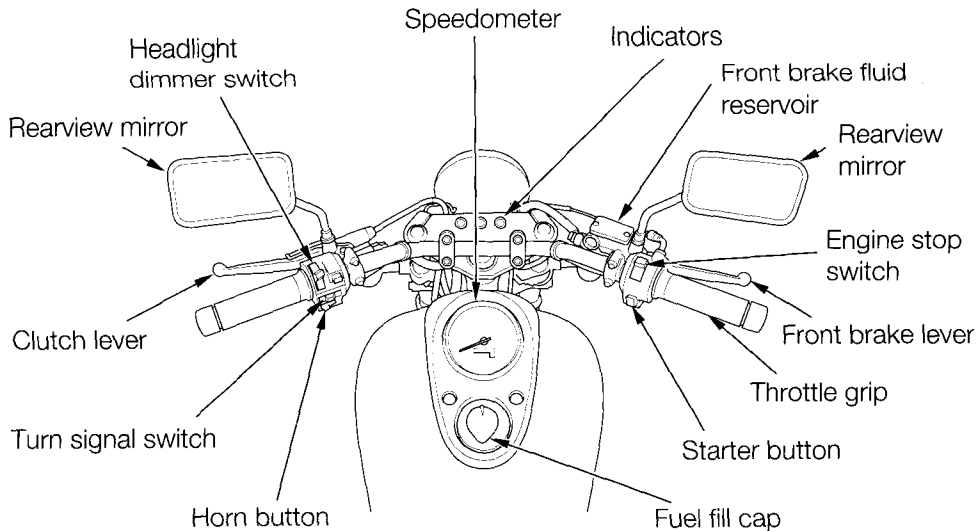

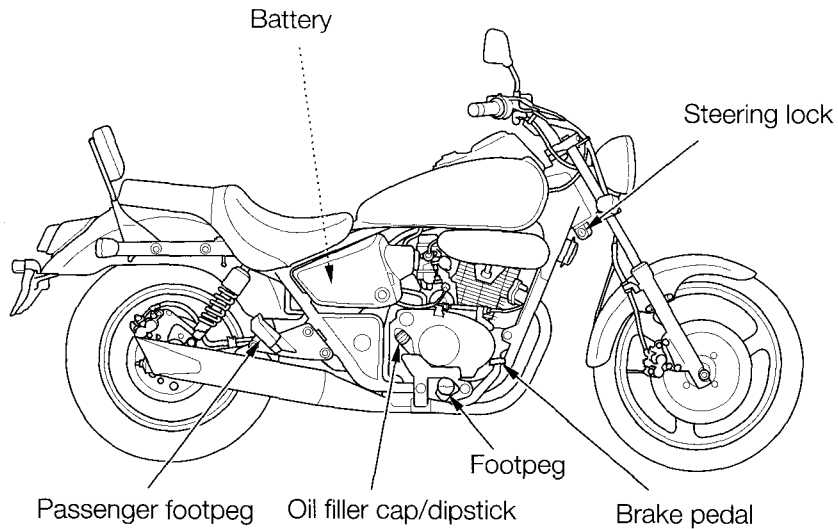

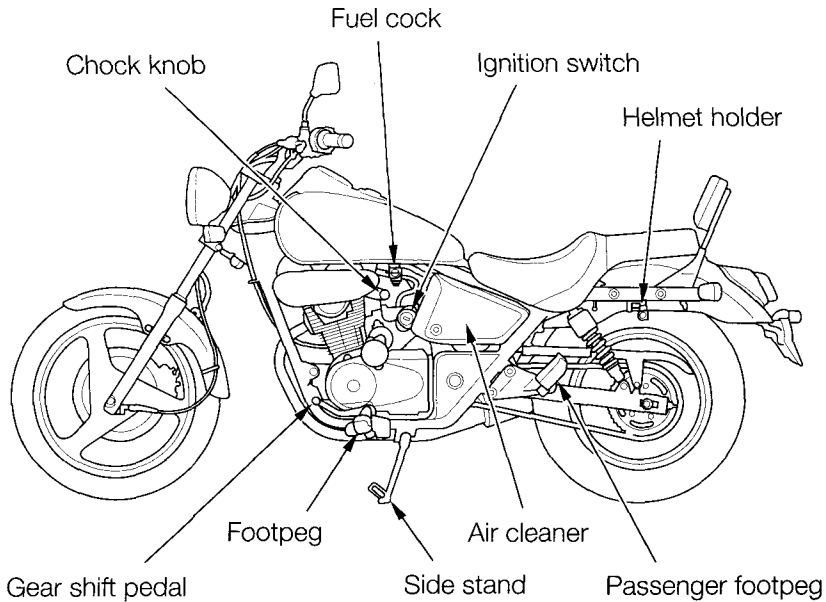

## INSTRUMENTS AND INDICATORS

The indicators are above the handlebar.  
Their functions are described in the table  
on the following page.

- (1) High beam indicator
- (2) Turn signal indicator
- (3) Neutral indicator
- (4) Speedometer
- (5) Odometer

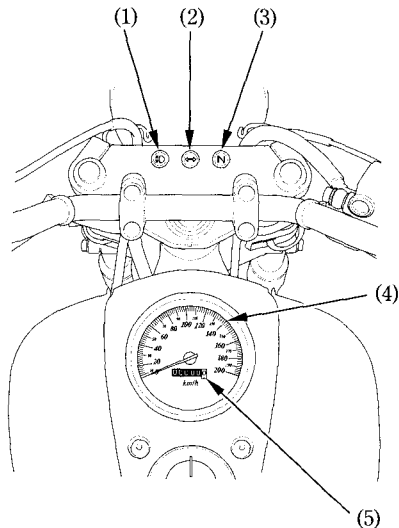

Ref. No.	Description	Function
(1)	High beam indicator (blue)	Light when the headlight is on high beam.
(2)	Turn signal indicator	Flashes when either turn signal is operated.
(3)	Neutral indicator (green)	Light when the transmission is in neutral.
(4)	Speedometer	Shows riding speed.
(5)	Odometer	Shows accumulated mileage.

## MAJOR COMPONENTS (Information you need to operate this motorcycle)

### **⚠ WARNING**

- If the **Pre-ride Inspection (page 35)** is not performed, severe personal injury or vehicle damage may result.

## SUSPENSION

Each shock absorber (1) has 5 adjustment positions for different load or riding conditions.

Use a pin spanner (2) to adjust the rear shocks.

Position 1 and 2 is for light loads and smooth road conditions. Positions 4 to 5 increase spring preload for a stiffer rear suspension, and can be used when the motorcycle is heavily loaded. Be certain to adjust both shock absorbers to the same position.

Standard position : 3

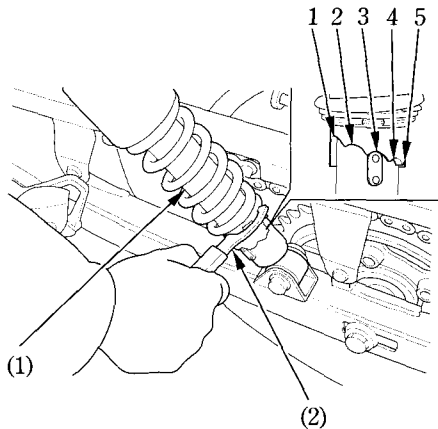

- (1) Shock absorber  
(2) Pin spanner

## BRAKES

Both the front and rear brakes are the hydraulic disc types.

As the brake pads wear, the brake fluid level drops.

There are no adjustments to perform, but fluid level and pad wear must be inspected periodically. The system must be inspected frequently to ensure there are no fluid leaks. If the control lever or pedal free travel becomes excessive and the brake pads are not worn beyond the recommended limit (page 67), there is probably air in the brake system and it must be bled. See your Honda dealer for this service.

### Front Brake

#### Brake Fluid Level :



- **Brake fluid may cause irritation. Avoid contact with skin or eyes. In case of contact, flush thoroughly with water and call a doctor if your eyes were exposed.**
- **KEEP OUT OF REACH OF CHILDREN.**

#### CAUTION :

- **Handle brake fluid with care because it can damage plastic and painted surfaces.**
- **When adding brake fluid, be sure the reservoir is horizontal before the cap is removed or brake fluid may spill out.**
- **Use only DOT 3 or 4 brake fluid from a sealed container.**
- **Never allow contaminants such as dirt or water to enter the brake fluid reservoir.**

Check that the fluid level is above the LOWER level mark (1) with the motorcycle in an upright position.

Brake fluid must be added to the reservoir whenever the fluid level begins to reach the LOWER level mark (1). Remove the screws (2), reservoir cover (3), diaphragm plate (4), and diaphragm (5). Fill the reservoir with DOT 3 or DOT 4 BRAKE FLUID from a sealed container up to the upper level mark (6). Reinstall the diaphragm, diaphragm plate, and cover. Tighten the screws securely.

#### Other Checks:

Make sure there are no fluid leaks. Check for deterioration or cracks in the hoses and fittings.

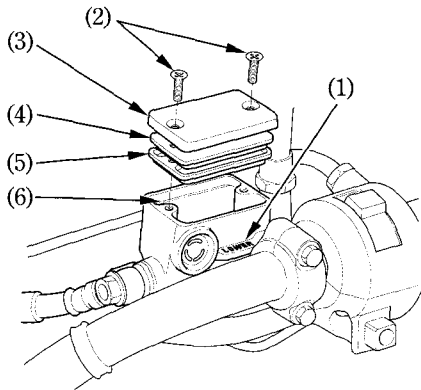

- |                      |                      |
|----------------------|----------------------|
| (1) LOWER level mark | (4) Diaphragm plate  |
| (2) Screws           | (5) Diaphragm        |
| (3) Reservoir cover  | (6) UPPER level mark |

## Rear Brake

### Rear Brake Fluid Level:

#### **⚠ WARNING**

- Brake fluid may cause irritation. Avoid contact with skin or eyes. In case of contact, flush thoroughly with water and call a doctor if your eyes were exposed.
- KEEP OUT OF REACH OF CHILDREN.

#### **CAUTION :**

- Handle brake fluid with care because it can damage plastic and painted surfaces.
- When adding brake fluid, be sure the reservoir is horizontal before the cap is removed or brake fluid may spill out.
- Use only DOT 3 or 4 brake fluid from a sealed container.
- Never allow contaminants such as dirt or water to enter the brake fluid reservoir.

Check the brake fluid level from the inspection window (1) of the right side cover.

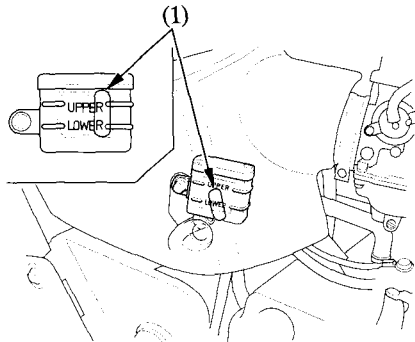

(1) Inspection window

Brake fluid must be added to the reservoir whenever the fluid level begins to reach the LOWER level mark (2). Remove the right side cover (page 32). Remove the screws (3), reservoir cover (4), diaphragm plate (5), and diaphragm (6). Fill the reservoir with DOT 3 or 4 BRAKE FLUID from a sealed container up to the UPPER level mark (7). Reinstall the diaphragm, diaphragm plate, cap and screws securely.

#### Other Checks:

Make sure there are no fluid leaks. Check for deterioration or cracks in the hoses and fittings.

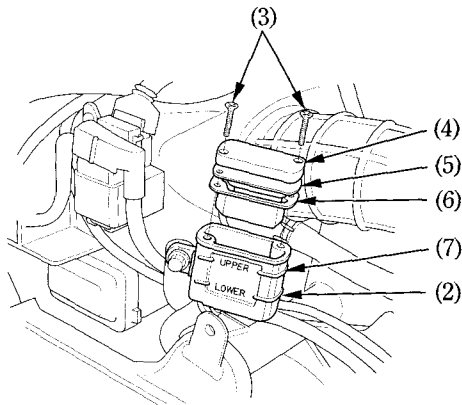

- (2) LOWER level mark
- (3) Screws
- (4) Reservoir cover
- (5) Diaphragm plate
- (6) Diaphragm
- (7) UPPER level mark

## CLUTCH

Clutch adjustment may be required if the motorcycle stalls when shifting into gear or tends to creep; or if the clutch slips, causing acceleration to lag behind engine speed. Minor adjustments can be made with the clutch cable adjuster (3) at the lever (1). Normal clutch lever free play is:

10 - 20 mm (0.4 - 0.8 in)

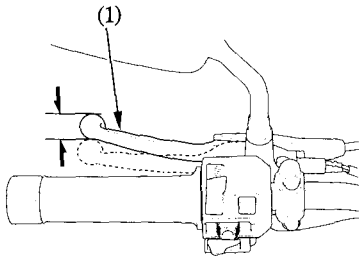

(1) Clutch lever

1. Loosen the lock nut (2) and turn the adjuster (3). Tighten the lock nut (2) and check the adjustment.
2. If the adjuster is threaded out near its limit or if the correct free play cannot be obtained, loosen the lock nut (2) and turn in the cable adjuster (3) completely. Tighten the lock nut (2).

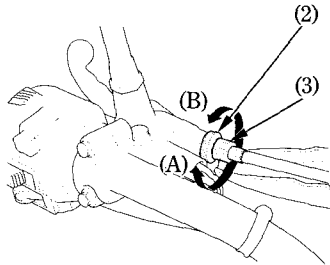

(2) Lock nut

(3) Clutch cable adjuster

(A) Increase free play

(B) Decrease free play

3. Loosen the lock nut (4) at the lower end of the cable. Turn the adjusting nut (5) to obtain the specified free play. Tighten the lock nut (4) and check the adjustment.
4. Start the engine, pull in the clutch lever and shift into gear. Make sure the engine does not stall and the motorcycle does not creep. Gradually release the clutch lever and open the throttle. The motorcycle should begin to move smoothly and accelerate gradually.

#### NOTE:

- If proper adjustment cannot be obtained or the clutch does not work correctly, see your Honda dealer.

#### Other Checks:

Check the clutch cable for kinks or signs of wear that could cause sticking or failure. Lubricate the clutch cable with a commercially available cable lubricant to prevent premature wear and corrosion.

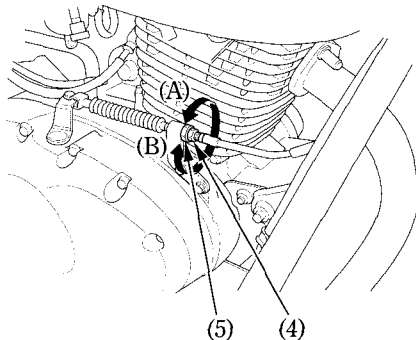

(4) Lock nut

(5) Adjusting nut

(A) Increase free play

(B) Decrease free play

## FUEL

### OFF

With the fuel cock in the OFF position, fuel cannot flow from the tank to the carburetor. Turn the cock OFF whenever the motorcycle is not in use.

### ON

With the fuel cock in the ON position, fuel will flow from the main fuel supply to the carburetor.

### RES

With the fuel cock in the RES position, fuel will flow from the reserve fuel supply to the carburetor. Use the reserve fuel only when the main supply is gone. Refill the tank as soon as possible after switching to RES.

The reserve fuel supply is:

2.68 l (0.708 US gal, 0.590 Imp gal)

## ⚠ WARNING

- To avoid running out of fuel that may result in a sudden stop, learn how to operate the fuel cock when riding the motorcycle.

## NOTE:

- Remember to check that the fuel cock is in the ON position each time you refuel. If the cock is left in the RES position, you may run out of fuel with no reserve.

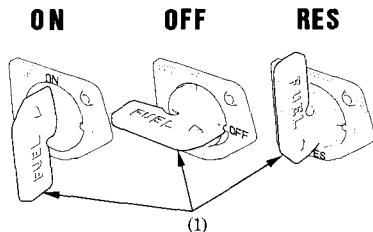

(1) Fuel cock

## Fuel Tank

The fuel tank capacity including the reserve supply is:

11.2 l (2.96 US gal, 2.46 Imp gal)

To open the fuel fill cap (1), insert the ignition key (2) and turn it clockwise. The fuel fill cap will pop up and can be lifted off. After refueling, to close the fuel fill cap, align the latch in the cap with the slot in the filler neck. Push the fuel fill cap into the filler neck until it snaps closed and locks. Remove the key.

Use unleaded petrol with a research octane number of 91 or higher.

The use of leaded petrol will cause premature damage to the catalytic converter.

## CAUTION:

- If “spark knock” or “pinking” occurs at a steady engine speed under normal load, change brands of petrol. If spark knock or pinking persists, consult your Honda dealer. Failure to do so is considered misuse, and damage caused by misuse is not covered by Honda’s Limited Warranty.

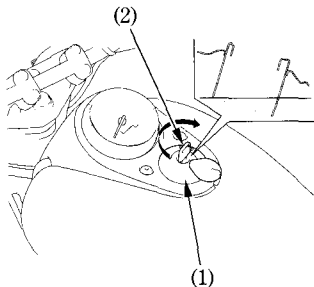

(1) Fuel fill cap (2) Ignition key

**⚠ WARNING**

- Petrol is extremely flammable and is explosive under certain conditions. Refuel in a well-ventilated area with the engine stopped. Do not smoke or allow flames or sparks in the area where petrol is stored or where the fuel tank is refueled.
  - Do not overfill the tank (there should be no fuel in the filler neck (3)). After refueling, make sure the fuel fill cap is closed securely.
  - Be careful not to spill fuel when refueling. Spilled fuel or fuel vapor may ignite. If any fuel is spilled, make sure the area is dry before starting the engine.
  - Avoid repeated or prolonged contact with skin or breathing of vapor.
- KEEP OUT OF REACH OF CHILDREN.**

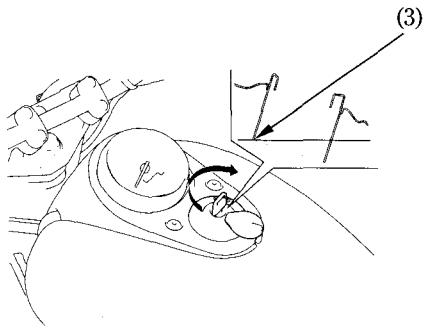

(3) Filler neck

## **Petrol Containing Alcohol**

If you decide to use a petrol containing alcohol (gasohol), be sure it's octane rating is at least as high as that recommended by Honda.

There are two types of "gasohol": one containing ethanol, and the other containing methanol.

Do not use petrol that contains more than 10 % ethanol.

Do not use petrol containing methanol (methyl or wood alcohol) that does not also contain cosolvents and corrosion inhibitors for methanol.

Never use petrol containing more than 5 % methanol, even if it has cosolvents and corrosion inhibitors.

## **NOTE:**

- When certain types of petrol containing alcohol are used, problems such as hard starting, poor performance, etc. may occur.
- If you notice any undesirable operating symptoms while using a petrol that contains alcohol, or one that you think contains alcohol, try another station or switch to another brand of petrol.
- When a problem resulting from the use of petrol containing alcohol occurs, contact your Honda dealer.

## ENGINE OIL

### Engine Oil Level Check

Check the engine oil level each day before riding the motorcycle.

The level must be maintained between the upper (1) and lower (2) level marks on the dipstick (3).

1. Start the engine and let it idle for a few minutes.
2. Stop the engine and hold the motorcycle in an upright position on firm, level ground.
3. After a few minutes, remove the oil filler cap/dipstick (3), wipe it clean, and reinsert the dipstick without screwing it in. Remove the dipstick. The oil level should be between the upper (1) and lower (2) level marks on the dipstick.
4. If required, add the specified oil (see page 53) up to the upper level mark. Do not overfill.

5. Reinstall the oil filler cap/dipstick. Check for oil leaks.

### CAUTION:

- **Running the engine with insufficient oil can cause serious engine damage.**

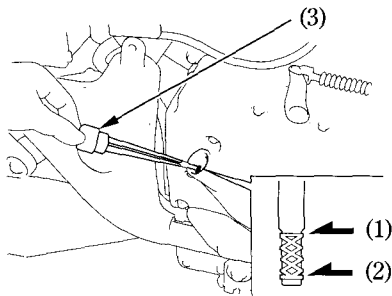

- (1) Upper level mark
- (2) Lower level mark
- (3) Oil filler cap/dipstick

## TUBELESS TYRES

This motorcycle is equipped with tubeless tyres, valves, and wheel rims. Use only tyres marked "TUBELESS" and tubeless valves on rims marked "TUBELESS TYRE APPLICABLE."

Proper air pressure will provide maximum stability, riding comfort and tyre life.

Check tyre pressure frequently and adjust if necessary.

### NOTE:

- Tyre pressure should be checked before you ride while the tyres are "cold".
- Tubeless tyres have some degree of selfsealing ability if they are punctured, and leakage is often very slow. Inspect very closely for punctures, especially if the tyre is not fully inflated.

Tyre size	
Front	90/90-17 49P
Rear	130/90-15 M/C 66P
Cold tyre pressures kPa (kgf/cm <sup>2</sup> , psi)	Driver only
	Front 200 (2.00 , 29)
	Rear 200 (2.00 , 29)
	Driver and one passenger
Front 200 (2.00 , 29)	
Rear 200 (2.00 , 29)	
Tyre brand TUBELESS ONLY	IRC
	Front NF52/TL Rear NR66/TL

Check the tyres for cuts, embedded nails or other sharp objects. Check the rims for dents or deformation. If there is any damage, see your Honda dealer for repair, replacement, and balancing.

**⚠ WARNING**

- **Improper tyre inflation will cause abnormal tread wear and create a safety hazard. Underinflation may result in the tyre slipping on, or coming off of the rim causing tyre deflation that may result in a loss of vehicle control.**
- **Operation with excessively worn tyres is hazardous and will adversely affect traction and handling.**

Replace tyres before tread depth at the center of the tyre reaches the following limit:

Minimum tread depth	
Front :	1.5 mm (0.06 in)
Rear :	2.0 mm (0.08 in)

## **Tyre Repair/Replacement:**

See your Honda Dealer.

### **⚠ WARNING**

- The use of tyres other than those listed on the tyre information label may adversely affect handling.
- Do not install tube-type tyres on tubeless rims. The beads may not seat and the tyres could slip on the rims, causing tyre deflation that may result in a loss of vehicle control.
- Do not install a tube inside a tubeless tyre. Excessive heat build-up may cause the tube to burst resulting in rapid tyre deflation that may result in a loss of vehicle control.
- Replace the tyre if the sidewall is punctured or damaged. Sidewall flexing may cause repair failure and tyre deflation that may result in a loss of vehicle control.

### **⚠ WARNING**

- To avoid possible repair failure and tyre deflation that may result in a loss of vehicle control, do not exceed 80 km/h (50 mph) for the first 24 hours, or 130 km/h (80 mph) at any time, after tyre repair.
- Proper wheel balance is necessary for safe, stable handling of the motorcycle. Do not remove or change any wheel balance weights. When wheel balancing is required, see your Honda dealer. Wheel balancing is required after tyre repair or replacement.
- Do not try to remove tubeless tyres without special tools and rim protectors. You may damage the rim sealing surface or disfigure the rim.

# ESSENTIAL INDIVIDUAL COMPONENTS

## IGNITION SWITCH

The ignition switch (1) is on front of left side cover.

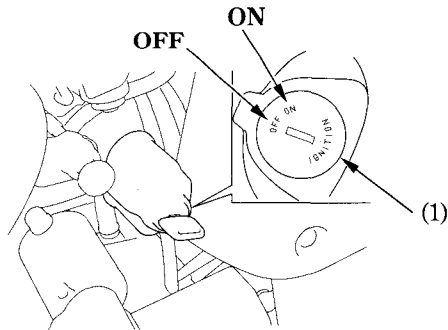

(1) Ignition switch

Key Position	Function	Key Removal
OFF	Engine and lights cannot be operated.	Key can be removed
ON	Engine and lights can be operated.	Key cannot be removed

## RIGHT HANDLEBAR CONTROLS

### Engine Stop Switch

The engine stop switch (1) is next to the throttle grip. When the switch is in the RUN position, the engine will operate. When the switch is in the OFF position, the engine will not operate. This switch is intended primarily as a safety or emergency switch and should normally remain in the RUN position.

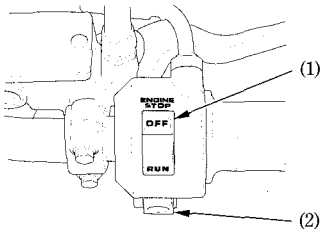

- (1) Engine stop switch
- (2) Starter button

### Starter Button

The starter button (2) is below the engine stop switch (1).

When the starter button is pressed, the starter motor cranks the engine. If the engine stop switch is in the OFF position, the starter motor will not operate. See page 37 for the starting procedure.

## LEFT HANDLEBAR CONTROLS

### Headlight Switch (1)

The headlight switch (1) has two positions: "H" and "OFF", marked by a dot below the "H".

H : Headlight, taillight and meter lights on.

OFF (dot) : Headlight, taillight and meter lights off.

### Headlight Dimmer Switch (2)

Push the headlight dimmer switch to "HI" to select high beam or to "LO" to select low beam.

### Turn Signal Switch (3)

Move to ◀ to signal a left turn, ▶ to signal a right turn. Press to turn signal off.

### Horn Button (4)

Press the button to sound the horn.

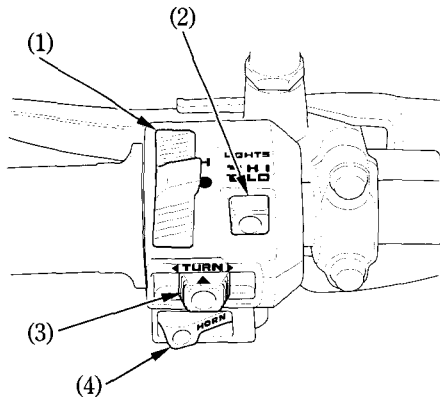

- (1) Headlight switch
- (2) Headlight dimmer switch
- (3) Turn signal switch
- (4) Horn button

# FEATURES

**(Not required for operation)**

## STEERING LOCK

The steering lock (1) is on the steering stem.

Turn the handlebar all the way to the left and insert the key into the lock, turn the key 180° clockwise and remove it.

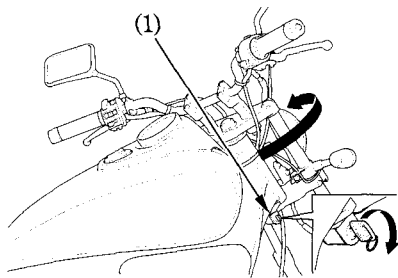

(1) Steering lock

## HELMET HOLDER

The helmet holder (1) is on the left side below the seat. Insert the ignition key (2) and turn it counterclockwise to unlock. Hang your helmet on the holder pin (3) and push it in to lock. Remove the key.

### **⚠ WARNING**

- **The helmet holder is designed for helmet security while parked. Do not ride with a helmet attached to the holder; the helmet may interfere with safe operation and result in loss of control.**

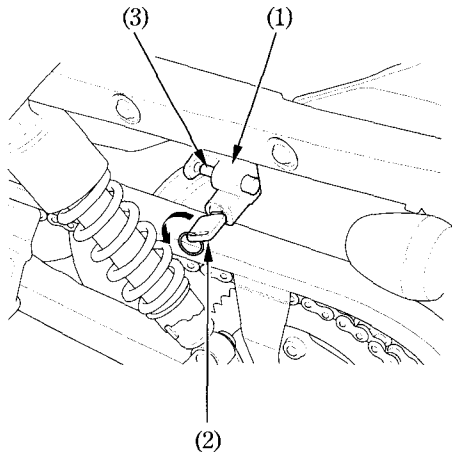

(1) Helmet holder

(3) Holder pin

(2) Ignition key

## SIDE COVER

To remove the right side cover (1) and left side cover (2), remove the screw and pull out the side covers.

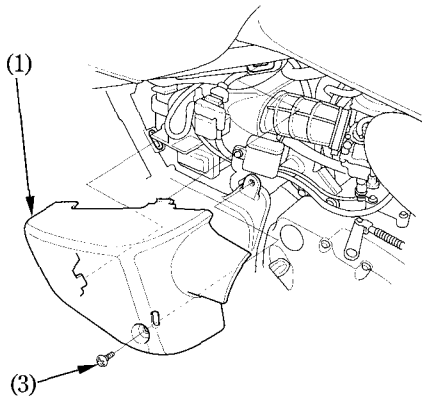

- (1) Right side cover
- (3) Screw

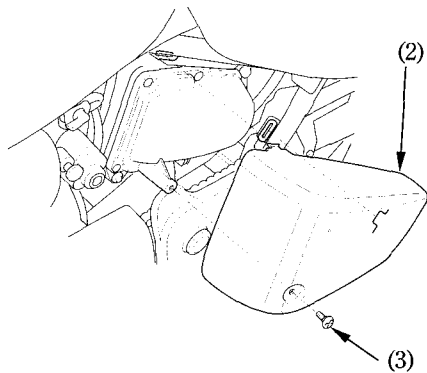

- (2) Left side cover

## DOCUMENT COMPARTMENT

The document compartment (1) is inside the left side cover (2) (page 31).

This owner's manual and other documents should be stored in this compartment.

When washing your motorcycle, be careful not to flood this area with water.

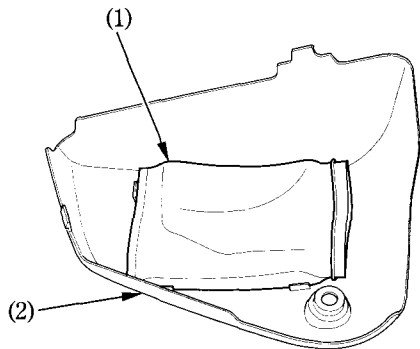

(1) Document compartment

(2) Left side cover

## SEAT

### Removal:

1. Remove the A bolt (1) and B bolts (2).
2. Pull the seat assembly (3) back and up.

### Installation:

1. Insert the seat tab (4) into the frame cross member (5).
2. Install the B bolts and A bolt.

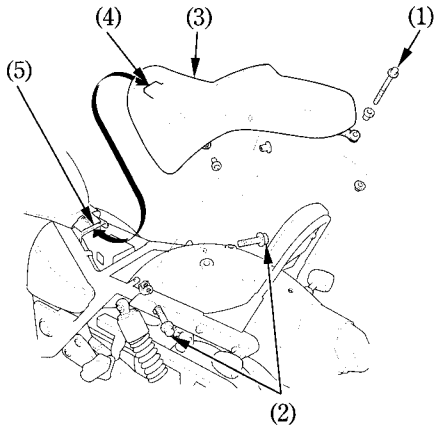

- (1) A bolt
- (2) B bolts
- (3) Seat assembly
- (4) Seat tab
- (5) Frame cross member

## HEADLIGHT AIM VERTICAL ADJUSTMENT

Vertical adjustment can be made by moving the headlight case (1) as necessary.

To move the headlight case (1), loosen the bolts (2) and nuts (3).

Tighten the bolts (2) and nuts (3) after adjustment.

Obey local laws and regulations.

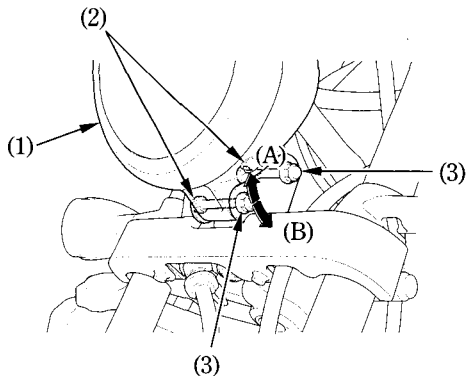

(1) Headlight case

(2) Bolts

(3) Nuts

(A) Up

(B) Down

# OPERATION

## PRE-RIDE INSPECTION

### WARNING

- **If the Pre-ride Inspection is not performed, severe personal injury or vehicle damage may result.**

Inspect your motorcycle every day before you ride it. The items listed here will only take a few minutes to inspect, and in the long run they can save time, expense, and possibly your life.

1. Engine oil level—add engine oil if required (page 22). Check for leaks.
2. Fuel level—fill fuel tank when necessary (page 18). Check for leaks.
3. Front and rear brakes—check operation; make sure there is no brake fluid leakage (page 12–15).

4. Tyres—check condition and pressure (page 23–25).
5. Drive chain—check condition and slack (page 60). Adjust and lubricate if necessary.
6. Throttle—check for smooth opening and full closing in all steering positions.
7. Lights and horn—check that headlight, tail/brake light, turn signals, indicators and horn function properly.
8. Engine stop switch—check for proper function (page 27).

Correct any discrepancy before you ride. Contact your Honda dealer for assistance if you cannot correct the problem.

## STARTING THE ENGINE

Always follow the proper starting procedure described below.

To protect the catalytic converter in your motorcycle's exhaust system, avoid extending idling and the use of leaded petrol.

### WARNING

- **Never run the engine in an enclosed area. The exhaust contains poisonous carbon monoxide gas that can cause loss of consciousness and lead to death.**
- **Do not try to start the motorcycle with the transmission in gear. You may injure yourself or damage the motorcycle.**

## Preparation

Before starting, insert the key, turn the ignition switch ON and confirm the following:

- The transmission is in NEUTRAL (neutral indicator light ON).
- The engine stop switch is at RUN.
- The fuel cock is ON.

## Starting Procedure

### Cold Engine:

1. Pull the choke knob (1) out all the way to Fully ON (A).
2. With the throttle closed, press the starter button.

### NOTE:

- Do not open the throttle when starting the engine with the choke ON. This will lean the mixture, resulting in hard starting.
3. When engine speed begins to pick up operate the choke knob (1) to keep fast idle.
  4. Continue warming up the engine until it runs smoothly and responds to the throttle, when the choke knob (1) is at fully OFF (B).

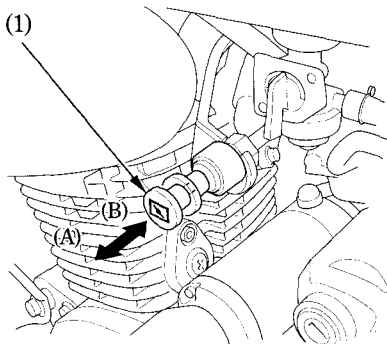

(1) Choke knob

(A) Fully ON

(B) Fully OFF

### Warm Engine:

1. Do not use the choke.
2. Open the throttle slightly.
3. Start the engine.

### **CAUTION:**

- **Snapping the throttle or fast idling for more than about 5 minutes at normal air temperature may cause exhaust pipe discoloration.**
- **Extended use of the choke may impair piston and cylinder wall lubrication and damage the engine.**

## **Flooded Engine**

If the engine fails to start after repeated attempts, it may be flooded with excess fuel. To clear a flooded engine, leave the engine stop switch on RUN and push the choke knob down to Fully OFF(B). Open the throttle fully and crank the engine for 5 seconds. If the engine starts, quickly close the throttle, then open it slightly if idling is unstable. If the engine does not start, wait 10 seconds, then follow the Starting Procedure.

## **RUNNING-IN**

Help assure your motorcycle's future reliability and performance by paying extra attention to how you ride during the first 500 km (300 miles). During this period, avoid full-throttle starts and rapid acceleration.

## RIDING

### **⚠ WARNING**

- **Review Motorcycle Safety (pages 1-5) before you ride.**

### **NOTE:**

- Make sure you understand the function of the side stand mechanism. (See MAINTENANCE SCHEDULE on page 46 and explanation for SIDE STAND on page 66).
  - Make sure flammable materials such as dry grass or leaves do not come in contact with the exhaust system when riding, idling, or parking your motorcycle.
1. After the engine has been warmed up, the motorcycle is ready for riding.
  2. While the engine is idling, pull in the clutch lever and depress the gearshift pedal to shift into 1st (low) gear.
  3. Slowly release the clutch lever and at the same time gradually increase engine speed by opening the throttle. Coordination

of the throttle and clutch lever will assure a smooth positive start.

4. When the motorcycle attains a moderate speed, close the throttle, pull in the clutch lever and shift to 2nd gear by raising the gearshift pedal.

This sequence is repeated to progressively shift to 3rd, 4th, 5th and 6th (top) gear.

5. Coordinate the throttle and brakes for smooth deceleration.
6. Both front and rear brakes should be used at the same time and should not be applied strongly enough to lock the wheel, or braking effectiveness will be reduced and control of the motorcycle be difficult.

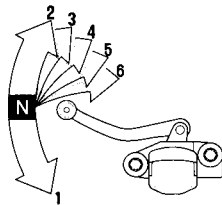

## **⚠ WARNING**

- **Do not downshift when traveling at a speed that would force the engine to overrev in the next lower gear; the rear wheel may lose traction, resulting in a possible loss of vehicle control.**

## **CAUTION:**

- **Do not shift gears without disengaging the clutch and closing the throttle. The engine and drive train could be damaged by overspeed and shock.**
- **Do not tow the motorcycle or coast for long distances while the engine is off. The transmission will not be properly lubricated and damage may result.**
- **Do not ride over a curb or rub the wheel against an obstacle, as wheel damage may result.**

## **NOTE:**

- The battery will not charge while the engine speed is near idle speed. Avoid idling for prolonged periods.

## BRAKING

1. For normal braking, gradually apply both the front and rear brakes while downshifting to suit your road speed.
2. For maximum deceleration, close the throttle and apply the front and rear brakes firmly. Pull in the clutch lever before coming to a complete stop to prevent stalling the engine.

### **⚠ WARNING**

- **Independent use of only the front or rear brake reduces stopping performance. Extreme braking may cause either wheel to lock, reducing control of the motorcycle.**
- **When possible, reduce speed or brake before entering a turn; closing the throttle or braking in mid-turn may cause wheel slip. Wheel slip will reduce control of the motorcycle.**

### **⚠ WARNING**

- **When riding in wet or rainy conditions, or on loose surfaces, the ability to maneuver and stop will be reduced. All of your actions should be smooth under these conditions. Rapid acceleration, braking or turning may cause loss of control. For your safety, exercise extreme caution when braking, accelerating or turning.**
- **When descending a long, steep grade, use engine compression braking by downshifting, with intermittent use of both brakes. Continuous brake application can overheat the brakes and reduce their effectiveness.**
- **Riding with your foot resting on the brake pedal or your hands on the brake lever may actuate the brakelight, giving a false indication to other drivers. It may also overheat the brake, reducing effectiveness.**

## PARKING

1. After stopping the motorcycle, shift the transmission into neutral, turn the fuel cock OFF, turn the handlebar fully to the left, turn the ignition switch OFF and remove the key.
2. Use the side stand to support the motorcycle while parked.

## CAUTION :

- **Park the motorcycle on firm, level ground to prevent it from falling over.**
  - **If you must park on a slight incline, aim the front of the motorcycle uphill to reduce the possibility of rolling off the side stand or overturning**
3. Lock the steering to help prevent theft (page 29).

## NOTE:

- Make sure flammable materials such as dry grass or leaves do not come in contact with the exhaust system when parking your motorcycle.

## ANTI-THEFT TIPS

1. Always lock the steering and never leave the key in the ignition switch. This sounds simple but people do forget.
2. Be sure the registration information for your motorcycle is accurate and current.
3. Park your motorcycle in a locked garage whenever possible.
4. Use an additional anti-theft device of good quality.
5. Put your name, address, and phone number in this Owner's Manual and keep it on your motorcycles at all times. Many times stolen motorcycles are identified by information in the Owner's Manuals that are still with them.

NAME : \_\_\_\_\_

ADDRESS : \_\_\_\_\_

\_\_\_\_\_

PHONE NO : \_\_\_\_\_

## MAINTENANCE

- The Required Maintenance Schedule specifies how often you should have your motorcycle served, and what things need attention. It is essential that your motorcycle be served as scheduled to retain its high level of safety, dependability, and emission control performance.
- These instructions are based on the assumption that the motorcycle will be used exclusively for its designed purpose. Sustained high speed operation, or operation in unusually wet or dusty conditions, will require more frequent service than specified in the MAINTENANCE SCHEDULE. Consult your Honda dealer for recommendations applicable to your individual needs and use.

# MAINTENANCE SCHEDULE

The following Maintenance Schedule specifies all maintenance required to keep your motorcycle in peak operating condition. Maintenance work should be performed in accordance with standards and specifications of Honda by properly trained and equipped technicians. Your Honda dealer meets all of these requirements.

Perform the Pre-ride Inspection (page 35) at each scheduled maintenance period.

I: INSPECT AND CLEAN, ADJUST, LUBRICATE OR REPLACE IF NECESSARY

C: CLEAN R: REPLACE A: ADJUST L: LUBRICATE

ITEMS		FREQUENCY	WHICHEVER → COMES FIRST ↓ NOTE	ODOMETER READING [NOTE (1)]				REFER TO PAGES	
				x1,000 km	1	4	8		12
				x1,000 mi	0.6	2.5	5		7.5
			MONTHS	6	12	18			
*	FUEL LINE				I	I	I	-	
*	FUEL STRAINER SCREEN				C	C	C	-	
*	THROTTLE OPERATION				I	I	I	58	
*	CARBURETOR CHOKE				I	I	I	-	
	AIR CLEANER	(NOTE 2)			C	C	R	51	
	CRANKCASE BREATHER	(NOTE 2)			C	C	C	52	
	SPARK PLUG				I	R	I	56	
*	VALVE CLEARANCE				I	I	I	-	
	ENGINE OIL				R	R	R	22, 53	
	ENGINE OIL STRAINER SCREEN						C	54	
**	ENGINE OIL CENTRIFUGAL FILTER						C	-	

ITEMS		FREQUENCY	WHICHEVER → COMES FIRST ↓	ODOMETER READING [NOTE (1)]				REFER TO PAGES	
				x1,000 km	1	4	8		12
		NOTE	x1,000 mi	0.6	2.5	5	7.5		
			MONTHS		6	12	18		
*	ENGINE IDLE SPEED								59
*	SECONDARY AIR SUPPLY SYSTEM	(NOTE 4)							-
*	EVAPORATIVE EMISSION CONTROL SYSTEM								-
	DRIVE CHAIN				EVERY 1,000 km (600 mi) I, L				60
	BRAKE FLUID	(NOTE 5)							12
	BRAKE PADS WEAR								67
	BRAKE SYSTEM								12-67
*	BRAKE LIGHT SWITCH								79
*	HEADLIGHT AIM								-
	CLUTCH SYSTEM								16
	SIDE STAND								66
*	SUSPENSION								66
*	NUTS, BOLTS, FASTENERS								-
**	WHEELS/TYRES								-
**	STEERING HEAD BEARINGS								-

- \* Should be serviced by your Honda dealer, unless the owner has the proper tools and service data and is mechanically qualified. Refer to the Official Honda Shop Manual.
- \*\* In the interest of safety, we recommend these items be serviced only by your Honda dealer.

Honda recommends that your Honda dealer should road test your motorcycle after each periodic maintenance is carried out.

- NOTES :**
1. At higher odometer readings, repeat at the frequency interval established here.
  2. Service more frequently if the motorcycle is ridden in unusually wet or dusty areas.
  3. Service more frequently when riding in rain or at full throttle.
  4. Replace every 3 years or 24,000 km (16,000 mile). Replacement requires mechanical skill.
  5. Replace every 2 years. Replacement requires mechanical skill.

## TOOL KIT

The tool kit (1) is in the tool box (2) behind the right side cover.

Remove the right side cover (page 31) and tool box lid (3).

Some roadside repairs, minor adjustments and parts replacement can be performed with the tools contained in the kit.

- 8x10 mm open end wrench
- 10x12 mm open end wrench
- 14x17 mm open end wrench
- Pliers
- Standard/Phillips screwdriver
- Screwdriver handle
- 22 mm box end wrench
- Pin spanner
- Extension bar
- Spark plug wrench
- Tool bag

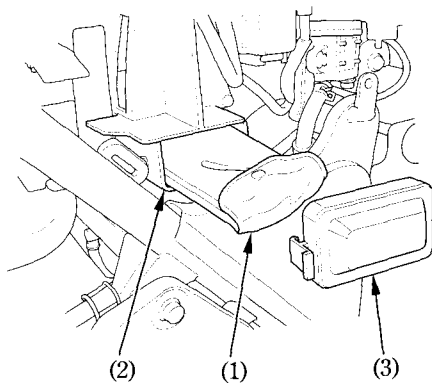

- (1) Tool kit
- (2) Tool box
- (3) Tool box lid

## SERIAL NUMBERS

The frame and engine serial numbers are required when registering your motorcycle. They may also be required by your dealer when ordering replacement parts. Record the numbers here for your reference.

FRAME NO. \_\_\_\_\_

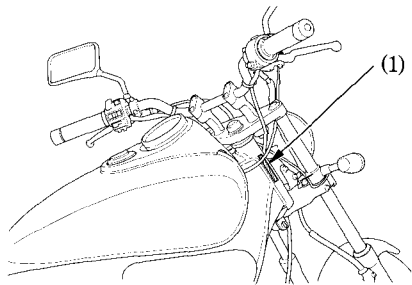

(1) Frame number

The frame number (1) is stamped on the right side of the steering head.

The engine number (2) is stamped on the left side of the crankcase.

ENGINE NO. \_\_\_\_\_

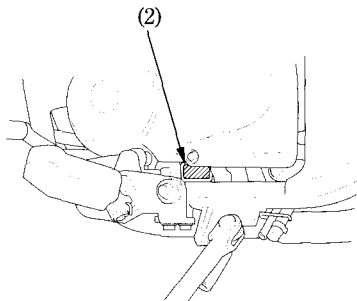

(2) Engine number

## MAINTENANCE PRECAUTIONS

### **⚠ WARNING**

- If your motorcycle is overturned or involved in a collision, inspect control levers, cables, accessories, and other vital parts for damage. Do not ride the motorcycle if damage impairs safe operation. Have your Honda dealer inspect the major components, including frame, suspension and steering parts, for misalignment and damage that you may not be able to detect.
- Use new, genuine Honda parts or their equivalent for maintenance and repair. Parts which are not of equivalent quality may impair the safety of your motorcycle.

### **⚠ WARNING**

- Stop the engine and support the motorcycle securely on a firm, level surface before performing any maintenance.

## AIR CLEANER

(Refer to the maintenance precautions on page 50).

The air cleaner should be serviced at regular intervals (page 45). Service more frequently when riding in unusually wet or dusty areas.

1. Remove the left side cover (page 31).
2. Remove the screws (1) and the air cleaner housing cover (2).

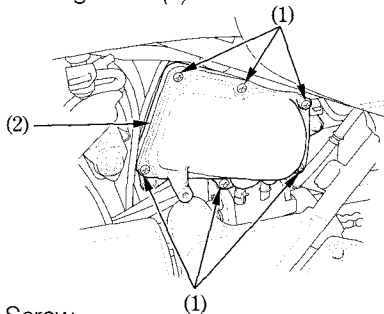

(1) Screw

(2) Air cleaner housing cover

3. Take out the air cleaner element (3) and clean the air cleaner element using compressed air from the outside, or replace it if necessary.
4. Install the air cleaner element.
5. Install the removed parts in the reverse order of removal.

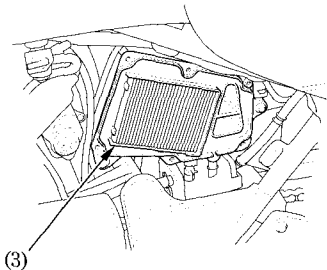

(3) Air cleaner

## CRANKCASE BREATHER

(Refer to the maintenance precautions on page 50).

1. Remove the crankcase breather tube plug (1) from the tube and drain deposits into a suitable container.
2. Reinstall the crankcase breather tube plug.

### NOTE:

- Service more frequently when riding in rain, at full throttle, or after the motorcycle is washed or overturned. Service if the deposit level can be seen in the transparent section of the drain tube.

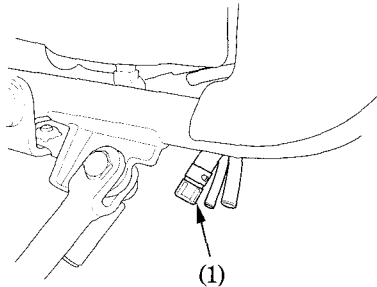

(1) Crankcase breather tube plug

## ENGINE OIL

(Refer to the maintenance precautions on page 50).

### Engine Oil

Good engine oil has many desirable qualities. Use only high detergent, quality motor oil certified on the container to meet or exceed requirements for API Service Classification SE, SF or SG. It is not necessary to use additives.

### Viscosity:

Viscosity grade of engine oil should be based on average atmospheric temperature in your riding area. The following provides a guide to the selection of the proper grade or viscosity of oil to be used at various atmospheric temperatures.

### CAUTION:

- **Do not use oils with graphite or molybdenum additives: they will adversely affect clutch operation.**

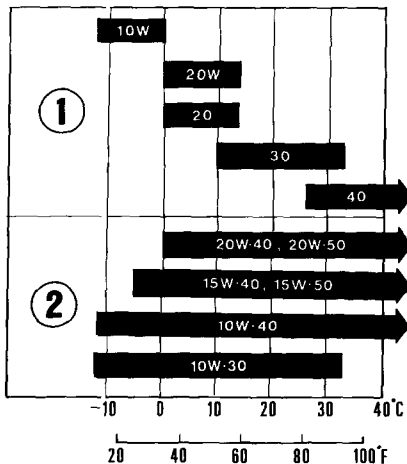

(1) Single grade (2) Multi grade

## Engine Oil/Oil Strainer Screen

Engine oil quality is the chief factor affecting engine service life. Change the engine oil as specified in the maintenance schedule (page 45).

### NOTE:

- Change the engine oil with the engine at normal operating temperature and the motorcycle on its side stand to assure complete and rapid draining.

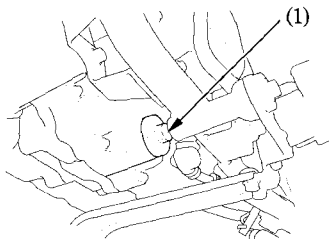

(1) Drain plug

1. Remove the oil filler cap from the right crankcase cover.
2. Place an oil drain pan under the crankcase and remove the oil drain plug (1).

### NOTE:

- The spring (2) and oil strainer screen (3) will come out when the drain plug is removed.
3. Clean the oil strainer screen.
  4. Check that the oil strainer screen, sealing rubber (4) and drain plug O-ring are in good condition.

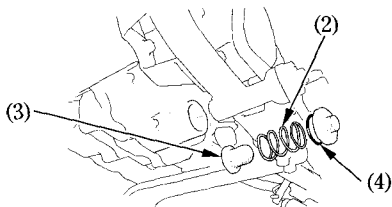

(2) Spring

(3) Oil strainer screen

(4) Sealing rubber

5. Install the oil strainer screen, spring and drain plug.
6. Fill the crankcase with the recommended grade oil; approximately:  
1.0 ℓ (1.1 US qt , 0.9 Imp qt)
7. Install the filler cap.
8. Start the engine and let it idle for 2–3 minutes.
9. Stop the engine and check that the oil level is at the upper level mark on the dipstick with the motorcycle upright on firm, level ground. Make sure there are no oil leaks.

## NOTE:

- Please dispose of used engine oil in a manner that is compatible with the environment. We suggest you take it in a sealed container to your local recycling center or service station for reclamation. Do not throw it in the rubbish or pour it on the ground or down a drain.

## CAUTION:

- **Used engine oil may cause skin cancer if repeatedly left in contact with the skin for prolonged periods. Although this is unlikely unless you handle used oil on a daily basis, it is still advisable to thoroughly wash your hands with soap and water as soon as possible after handling used oil.**

## SPARK PLUG

(Refer to the maintenance precautions on page 50).

Recommended plug:

Standard:

**DPR8EA 9 (NGK) or  
X24EPR U9 (DENSO)**

1. Remove the screws (1) and right front side cover (2).

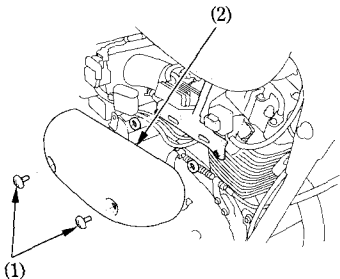

2. Disconnect the spark plug cap (3) from the spark plug.
3. Clean any dirt from around the spark plug bases. Remove the spark plug using the plug wrench (4) furnished in the tool kit.
4. Inspect the electrodes and center porcelain for deposits, erosion or carbon fouling. If the erosion or deposit is heavy, replace the plug. Clean a carbon or wetfouled plug with a plug cleaner, otherwise use a wire brush.

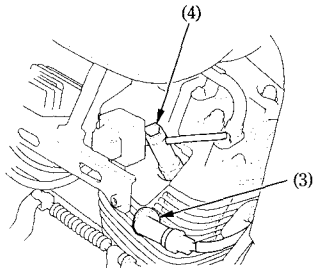

(1) Screws

(2) Right front side cover

(3) Spark plug cap

(4) Plug wrench

5. Check the spark plug gap (3) using a wire-type feeler gauge. If adjustment is necessary, bend the side electrode (4) carefully.

The gap should be:

0.80-0.90 mm (0.031-0.035 in)

Make sure the plug washer is in good condition.

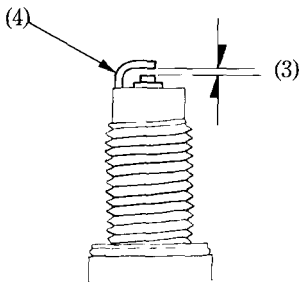

(2) Spark plug gap    (3) Side electrode

6. With the plug washer attached, thread the spark plug in by hand to prevent cross-threading.
7. Tighten a new spark plug 1/2 turn with a spark plug wrench to compress the washer. If you are reusing a plug, it should only take 1/8-1/4 turn after the plug seats.
8. Reinstall the spark plug cap, right front side cover and screws.

#### CAUTION :

- **The spark plug must be securely tightened. An improperly tightened plug can become very hot and possibly damage the engine.**
- **Never use a spark plug with an improper heat range. Severe engine damage could result.**

## THROTTLE OPERATION

(Refer to the maintenance precautions on page 50).

1. Check for smooth rotation of the throttle grip from the fully open to the fully closed position at both full steering positions.
2. Measure the throttle grip free play at the throttle grip flange.  
The standard free play should be approximately:

**2-6 mm (0.08-0.24 in)**

To adjust the free play, loosen the lock nut (1) and turn the adjuster (2).

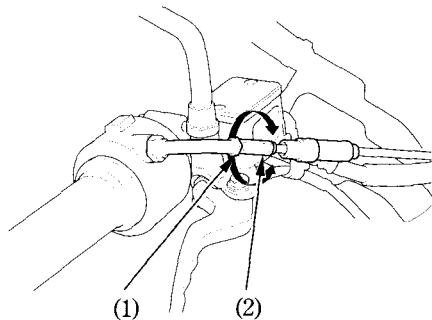

(1) Lock nut

(2) Adjuster

## IDLE SPEED

(Refer to the maintenance precautions on page 50).

The engine must be at normal operating temperature for accurate idle speed adjustment. Ten minutes of stop-and-go riding is sufficient.

### NOTE :

- Do not attempt to compensate for faults in other systems by adjusting idle speed. See your Honda dealer for regularly scheduled carburetor adjustments, including individual carburetor adjustment and synchronization.
1. Warm up the engine, shift to neutral and place the motorcycle on its side stand.
  2. Connect a tachometer to the engine.

3. Adjust idle speed with the throttle stop screw (1).

Idle speed (In neutral):

**1,400 ± 100 (rpm)**

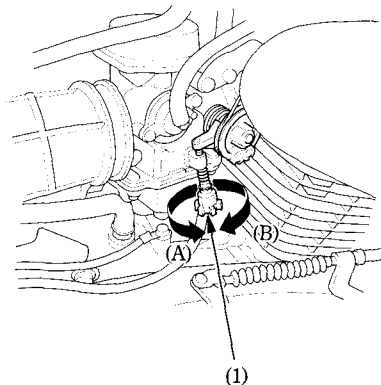

- (1) Throttle stop screw      (A) Increase  
(B) Decrease

## DRIVE CHAIN

(Refer to the maintenance precautions on page 50).

The service life of the drive chain is dependent upon proper lubrication and adjustment. Poor maintenance can cause premature wear or damage to the drive chain and sprockets.

The drive chain should be checked and lubricated as part of the Pre-ride Inspection (page 35). Under severe usage, or when the motorcycle is ridden in unusually dusty or muddy areas, more frequent maintenance will be necessary.

### Inspection:

1. Turn the engine off, place the motorcycle on its side stand and shift the transmission into neutral.
2. Check slack in the lower drive chain run midway between the sprockets. Drive chain slack should be adjusted to allow the following vertical movement by hand:

20–30 mm (0.8–1.2 in)

3. Roll the motorcycle forward. Stop. Check drive chain slack. Repeat this procedure several times. Drive chain slack should remain constant. If the chain is slack only in certain sections, some links are kinked and binding. Binding and kinking can frequently be eliminated by lubrication.

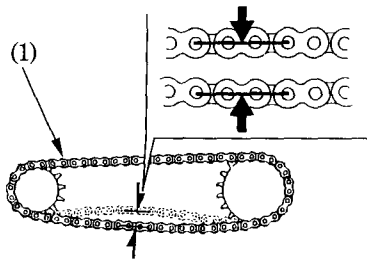

(1) Drive chain

4. Rotate the rear wheel slowly and inspect the drive chain and sprockets for any of the following conditions:

#### DRIVE CHAIN

- Damaged Rollers
- Loose Pins
- Dry or Rusted Links
- Kinked or Binding Links
- Excessive Wear
- Improper Adjustment
- Damaged or Missing O-rings

#### SPROCKETS

- Excessively Worn Teeth
- Broken or Damaged Teeth

A drive chain with damaged rollers, loose pins, or missing O-rings must be replaced. A chain which appears dry, or shows signs of rust, requires supplementary lubrication. Kinked or binding

links should be thoroughly lubricated and worked free. If links cannot be freed, the chain must be replaced.

Damaged Sprocket  
Teeth  
REPLACE

Worn Sprocket  
Teeth  
REPLACE

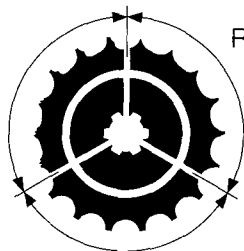

Normal Sprocket Teeth  
GOOD

### Adjustment:

Drive chain slack should be checked and adjusted, if necessary, every 1,000 km (600 miles). When operated at sustained high speeds or under conditions of frequent rapid acceleration, the chain may require more frequent adjustment.

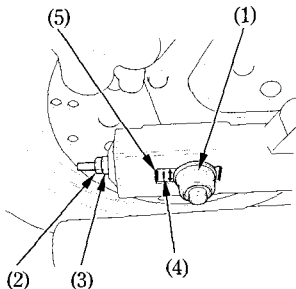

- |                                  |                   |
|----------------------------------|-------------------|
| (1) Axle nut                     | (4) Index mark    |
| (2) Lock nut                     | (5) Rear edge     |
| (3) Drive chain<br>adjusting nut | of adjusting slot |

If the drive chain requires adjustment, the procedure is as follows:

1. Place the motorcycle on its side stand with the transmission in neutral and the ignition switch off.
2. Loosen the axle nut (1).
3. Loosen the lock nuts (2) on both adjusting nuts (3).
4. Turn both adjusting nuts (3) an equal number of turns until the correct drive chain slack is obtained. Turn the adjusting nuts clockwise to tighten the chain, or counterclockwise to provide more slack. Adjust the chain slack at a point midway between the drive sprocket and the rear wheel sprocket. Rotate the rear wheel and recheck slack at other sections of the chain.

Chain slack should be:

**20–30 mm (0.8–1.2 in)**

5. Check rear axle alignment by confirming the chain adjuster index marks (4) against the rear edge (5) of the adjusting slots. Both left and right marks should correspond. If the axle is misaligned, turn the left or right adjusting nut until the marks correspond on the rear edge of the adjusting slots and recheck chain slack.
6. Tighten the axle nut to specified torque.  
88 N·m (9.0 kgf·m , 65 lbf·ft)
7. Tighten the adjusting nuts lightly, then tighten the lock nuts by holding the adjusting nuts with a spanner.
8. Recheck drive chain slack.

**⚠ WARNING**

- **If a torque wrench is not used for this installation, see your Honda dealer as soon as possible to verify proper assembly.**

**CAUTION:**

- **Damage to the bottom part of the frame may be caused by excessive drive chain slack of more than:  
50 mm (2.0 in)**

Wear inspection:

Check the chain wear label when adjusting the chain. If the red zone (6) on the label aligns with the rear edge of the axle washer (7) after the chain has been adjusted to the proper slack, the chain is excessively worn and must be replaced. The proper slack is:

**20–30 mm (0.8–1.2 in)**

Replacement Chain:

**RK 520 M09**

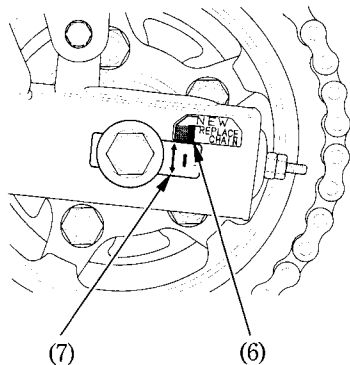

(6) Red zone

(7) Rear edge of the axle washer

### Lubrication and cleaning:

Lubricate every 1,000 km (600 miles) or sooner if chain appears dry.

The O-rings in this chain can be damaged by steam cleaning, high pressure washers, and certain solvents. Clean the side surfaces of the chain with a dry cloth. Do not brush the rubber O-rings. Brushing will damage them. Wipe dry and lubricate only with SAE 80 or 90 gear oil. Commercial chain lubricants may contain solvents which could damage the rubber O-rings.

### CAUTION:

- **The drive chain on this motorcycle is equipped with small O-rings between the link plates. These O-rings retain grease inside the chain to improve its service life. However, special precautions must be taken when adjusting, lubricating, washing, and replacing the chain.**

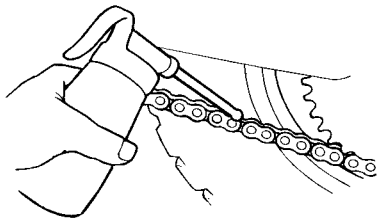

## FRONT AND REAR SUSPENSION INSPECTION

(Refer to the maintenance precautions on page 50).

1. Check the fork assembly by locking the front brake and pumping the fork up and down vigorously. Suspension action should be smooth and there must be no oil leakage.
2. Swingarm bearings should be checked by pushing hard against the side of the rear wheel while the motorcycle is on a support block. Free play indicates worn bearings.
3. Carefully inspect all front and rear suspension fasteners for tightness.

## SIDE STAND

(Refer to the maintenance precautions on page 50).

Check the side stand spring (1) for damage and loss of tension, and the side stand assembly for freedom of movement.

If the side stand is squeaky or stiff, clean the pivot area and lubricate the pivot bolt with clean engine oil.

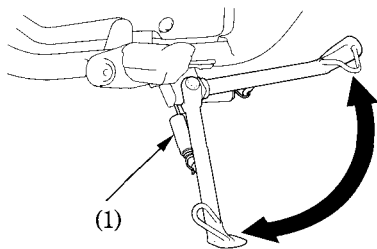

(1) Side stand spring

## BRAKE PAD WEAR

(Refer to the maintenance precautions on page 50).

Brake pad wear depends upon the severity of usage, the type of riding, and road conditions. (Generally, the pads will wear faster on wet and dirty roads.)

Inspect the pads at each regular maintenance interval (page 46).

### Front Brake

Check the wear indicator mark (1) on each pad.

If either pad is worn to the wear indicator mark, replace both pads as a set. See your Honda dealer for this service.

<FRONT BRAKE>

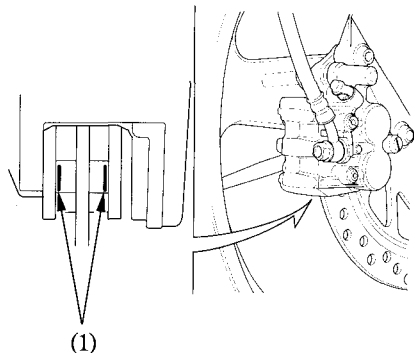

(1) Wear indicator mark

## Rear Brake

Check the wear indicator mark (2) on each pad.

If either pad is worn to the wear indicator mark, replace both pads as a set. See your Honda dealer for this service.

<REAR BRAKE>

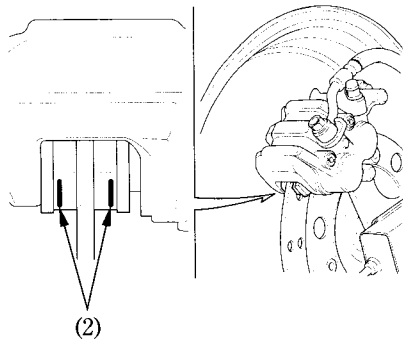

(2) Wear indicator mark

## WHEEL REMOVAL

(Refer to the maintenance precautions on page 50).

### NOTE:

- This motorcycle is equipped with a side stand only. Therefore, if front or rear wheel removal is required, it will be necessary to raise the center of the motorcycle with a jack or other firm support. If none is available, see your Honda dealer for this service.

### Front Wheel Removal

1. Raise the front wheel off the ground by placing a support block under the engine.
2. Disconnect the speedometer cable (1) by removing the speedometer cable set screw (2).

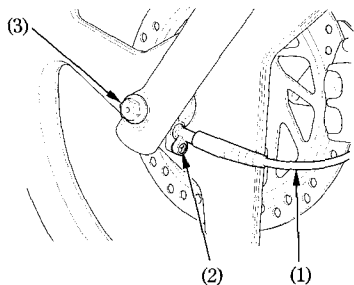

- (1) Speedometer cable
- (2) Speedometer cable set screw
- (3) Axle shaft

3. Remove the axle shaft (3) and axle nut (4). Remove the front wheel.

**NOTE:**

- Do not depress the brake lever when the wheel is off the motorcycle. The caliper pistons will be forced out of the cylinders with subsequent loss of brake fluid. If this occurs, servicing of the brake system will be necessary. See your Honda dealer for this service.

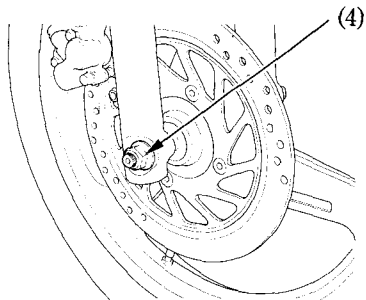

(4) Axle nut

### Installation Notes:

- To install the front wheel assembly, install the brake disc between the brake pads taking care not to damage the brake pads and insert the axle through the left fork leg.
- Make sure that the lugs (5) on the fork leg is contacting the lugs on the speedometer gear box. Tighten the axle nut to specified torques.

Axle nut torque:

**59 N·m (6.0 kgf·m , 43 lbf·ft)**

- After installing the wheel, apply the brake several times and then check if the wheel rotates freely. Recheck the wheel if the brake drags or if the wheel does not rotate freely.

### **⚠ WARNING**

- **If a torque wrench was not used for installation, see your Honda dealer as soon as possible to verify proper assembly. Improper assembly may lead to loss of braking capacity.**

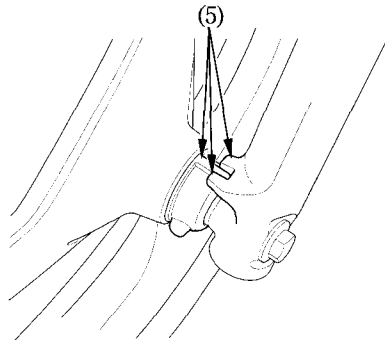

(5) Lugs

## Rear Wheel Removal

1. Raise the rear wheel off the ground by placing a support block under the engine.
2. Loosen the rear axle nut.
3. Loosen the locknuts (2).
4. Loosen the drive chain adjusting nuts (3).
5. Remove the rear axle nut.
6. Remove the drive chain (4) from the driven sprocket by pushing the rear wheel forward.

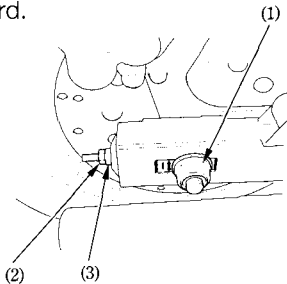

- (1) Rear axle nut  
(2) Lock nuts

- (3) Drive chain  
adjusting nuts

7. Remove the axle shaft (5), side collar and rear wheel from the swing arm.

## NOTE:

- Do not depress the brake pedal while the wheel is off the motorcycle. The caliper pistons will be forced out of the cylinders with subsequent loss of brake fluid. If this occurs, servicing of the brake system will be necessary. See your Honda dealer for this service.

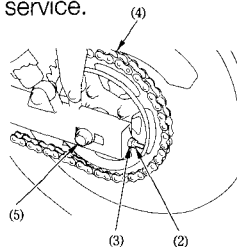

- (2) Lock nuts  
(3) Drive chain  
adjusting nuts

- (4) Drive chain  
(5) Axle shaft

### Installation:

To install the rear wheel, reverse the removal procedure. Torque the axle nut to the specified torque.

Axle nut torque:

88 N·m (9.0 kgf·m , 65 lbf·ft)

### **CAUTION:**

- **When installing the wheel, carefully fit the brake disc between the brake pads to avoid damaging the pads.**

After installing the wheel, apply the brake several times and then check if the wheel rotates freely. Recheck the wheel if the brake drags or if the wheel does not rotate freely.

### **⚠ WARNING**

- **If a torque wrench was not used for installation, see your Honda dealer as soon as possible to verify proper assembly. Improper assembly may lead to loss of braking capacity.**

## BATTERY

(Refer to the maintenance precautions on page 50).

It is not necessary to check the battery electrolyte level or add distilled water as the battery is a maintenance-free (sealed) type. If your battery seems weak add/or is leaking electrolyte (causing hard starting or other electrical troubles), contact your Honda dealer.

## CAUTION :

- **Removing the battery cap strip can damage the cap strip and result in leaks and eventual battery damage.**
- **When the motorcycle is to be stored for an extended period of time, remove the battery from the motorcycle and charge it fully. Then store it in a cool, dry place. If the battery is to be left in the motorcycle, disconnect the negative cable from the battery terminal.**

**⚠ WARNING**

- The battery gives off explosive gases; keep sparks, flames, and cigarettes away. Provide adequate ventilation when charging or using the battery in an enclosed space.
- The battery contains sulfuric acid (electrolyte). Contact with skin or eyes may cause severe burns. Wear protective clothing and a face shield.
  - If electrolyte gets on your skin, flush with water.
  - If electrolyte gets in your eyes, flush with water for at least 15 minutes and call a physician immediately.
- Electrolyte is poisonous.
  - If swallowed, drink large quantities of water or milk and follow with milk of magnesia or vegetable oil and call a physician.
- **KEEP OUT OF REACH OF CHILDREN.**

### Battery Removal:

1. Remove the seat (page 33).
2. Release the ring (1).
3. Disconnect the negative (-) terminal lead (2) from the battery first.
4. Disconnect the positive (+) terminal lead (3).
5. Lift up the battery box (5) then pull out the battery (4).

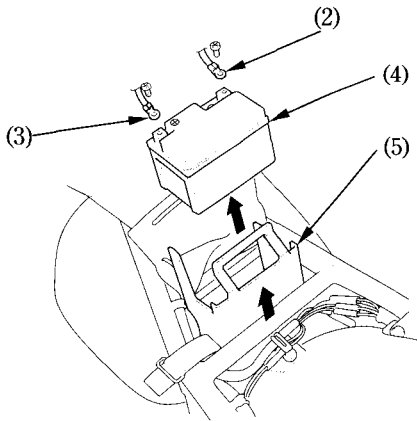
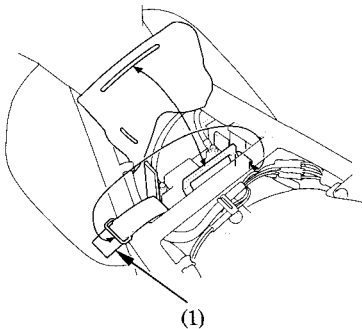

- (1) Ring
- (2) Negative (-) terminal lead
- (3) Positive (+) terminal lead
- (4) Battery
- (5) Battery box

## FUSE REPLACEMENT

(Refer to the maintenance precaution on page 50).

When frequent fuse failure occurs, it usually indicates a short circuit or an overload in the electrical system. See your Honda dealer for repair.

### CAUTION :

- **Turn the ignition switch OFF before checking or replacing fuses to prevent accidental short-circuiting.**

### **⚠ WARNING**

- **Never use a fuse with a different rating from that specified. Serious damage to the electrical system or a fire may result, causing a dangerous loss of lights or engine power.**

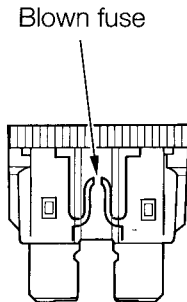

### Main fuse:

The main fuse (1) is located behind the right side cover. The specified fuse is:

**15A**

1. Remove the right side cover (page 31).
2. Disconnect the wire connector (2) of the stater magnetic switch (3).
3. Pull out the fuse. If the fuse is blown install a new fuse. The spare main fuse (4) is located near the starter magnetic switch.
4. Reconnect the wire connector and install the right side cover.

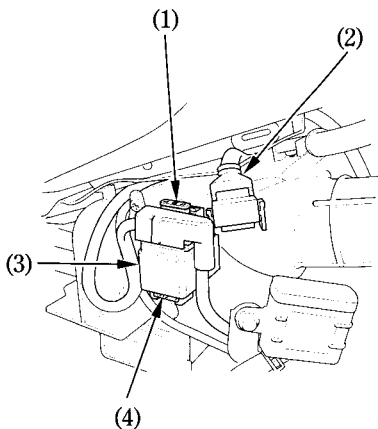

- (1) Main fuse
- (2) Wire connector
- (3) Starter magnetic switch
- (4) Spare main fuse

## STOPLIGHT SWITCH ADJUSTMENT

(Refer to the maintenance precautions on page 50).

Check the operation of the stoplight switch (1) at the right side behind the engine from time to time.

Adjustment is done by turning the adjusting nut (2). Turn the nut in the direction (A) if the switch operates too late and in direction (B) if the switch operates too soon.

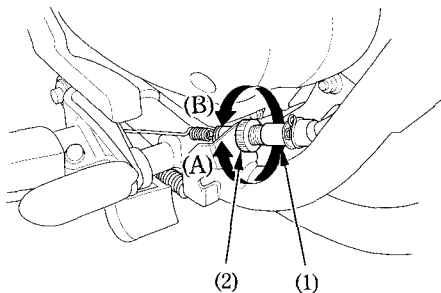

- (1) Stoplight switch
- (2) Adjusting nut

## BULB REPLACEMENT

(Refer to the maintenance precautions on page 50).

### WARNING

- **The light bulb becomes very hot while the light is ON, and remain hot for a while after it is turned OFF. Be sure to let it cool down before servicing.**

### CAUTION:

- **Do not put finger prints on the headlight bulb, as they may create hot spots on the bulb and cause it to break.**  
**Wear clean gloves while replacing the bulb.**  
**If you touch the bulb with your bare hands, clean it with a cloth moistened with alcohol to prevent its early failure.**

### NOTE:

- Be sure to turn the ignition switch OFF when replacing the bulb.
- Do not use bulbs other than that specified.
- After installing a new bulb, check that the light operates properly.

## Headlight/Position Light Bulb

1. Remove the two bolts (1) from the headlight case.
2. Gently pull the lower end of the headlight (2) forward and remove the headlight.
3. Disconnect the connector (3).
4. Remove the seat rubber (4).

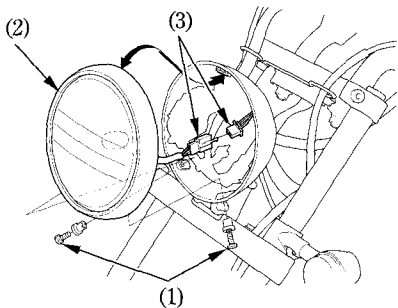

(1) Bolts  
(2) Headlight

(3) Connector

5. Remove the socket (5) from headlight by slightly pressing the socket and turning it counterclockwise.
6. Remove the bulb (6).
7. Install a new bulb in the reverse order of removal.

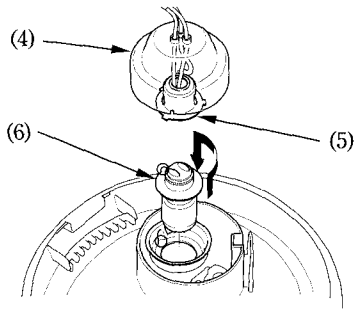

(4) Seat rubber  
(5) Socket

(6) Bulb

## Stop/Taillight Bulb

1. Remove the taillight lens (1) by removing the two screws (2).
2. Slightly press the bulb (3) and turn it counterclockwise.
3. Install a new bulb in the reverse order of removal.

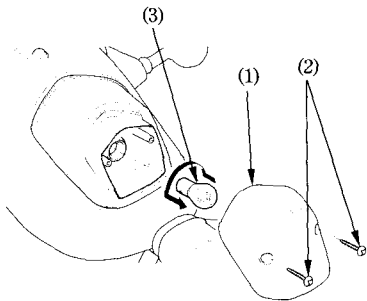

(1) Taillight lens  
(2) Screws

(3) Bulb

## Front/Rear Turn Signal Bulb

1. Remove the turn signal lens (1) by removing the screw (2).
2. Remove the socket (3) by turning it counterclockwise.
3. Pull out the bulb (4).
4. Install a new bulb in the reverse order of removal.

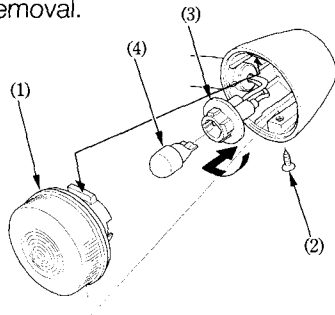

(1) Turn signal lens  
(2) Screw

(3) Socket  
(4) Bulb

## License Light Bulb

1. Remove the license light cover (1) and license light lens (2) by removing the two screws (3).
2. Pull out the bulb (4).
3. Install a new bulb in the reverse order of removal.

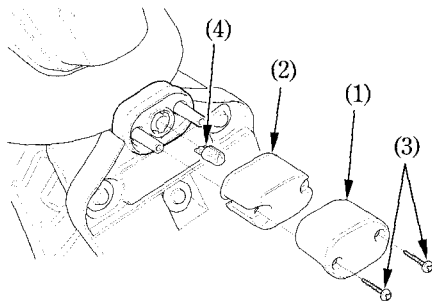

- |                         |            |
|-------------------------|------------|
| (1) License light cover | (3) Screws |
| (2) License light lens  | (4) Bulb   |

## CLEANING

Clean your motorcycle regularly to protect the surface finishes and inspect for damage, wear and oil leakage.

### CAUTION :

- **High pressure water (or air) can damage certain parts of the motorcycle.**

Avoid spraying high pressure water (typical in coin-operated car washes) at the following areas:

Wheel Hubs	Drive Chain
Ignition Switch	Under Seat
Carburetor	Headlight
Brake Master Cylinders	
Instruments	
Handlebar Switches	
Muffler Outlet	
Under Fuel Tank	

1. After cleaning, rinse the motorcycle thoroughly with plenty of clean water. Strong detergent residue can corrode alloy parts.

### NOTE :

- Clean the fairing, headlight lens, meter lens and other plastic parts using a cloth or sponge dampened with a solution of mild detergent and water. Rub the soiled area gently rinsing it frequently with fresh water.
- The inside of the headlight lens may be clouded immediately after washing the motorcycle. Moisture condensation inside the headlight lens will disappear gradually by lighting the headlight in high beam. Run the engine while keeping the headlight on.

2. Dry the motorcycle, start the engine, and let it run for several minutes.

**⚠ WARNING**

- **Braking efficiency may be temporarily impaired immediately after washing the motorcycle. Anticipate longer stopping distance to avoid a possible accident.**

3. Test the brakes before riding the motorcycle. Several applications may be necessary to restore normal braking performance.
4. Lubricate the drive chain immediately after washing and drying the motorcycle.

### **Painted Aluminum Wheel Maintenance**

Aluminum may corrode from contact with dirt, mud, or road salt. Clean the wheels after riding through any of these substances. Use a wet sponge and mild detergent. Avoid stiff brushes, steel wool, or cleaners containing abrasives or chemical compounds.

After washing, rinse with plenty of water and dry with a clean cloth.

Apply touch-up paint to the wheels where damage has resulted.

## STORAGE GUIDE

Extended storage, such as for winter, requires that you take certain steps to reduce the effects of deterioration from non-use of the motorcycle. In addition, necessary repairs should be made BEFORE storing the motorcycle; otherwise, these repairs may be forgotten by the time the motorcycle is removed from storage.

### STORAGE

1. Change the engine oil.
2. Empty the fuel tank into an approved petrol container using a commercially available hand siphon or an equivalent method. Spray the inside of the tank with an aerosol rust-inhibiting oil. Reinstall the fuel fill cap on the tank.

### NOTE:

- If storage will last more than one month, carburetor draining is very important, to assure proper performance after storage.

### WARNING

- **Petrol is extremely flammable and is explosive under certain conditions. Perform this operation in a well-ventilated area with the engine stopped. Do not smoke or allow flames or sparks in the area where petrol is drained or stored and where the fuel tank is refueled.**

3. To prevent rusting in the cylinder, perform the following:
  - Remove the spark plug cap from the spark plug. Using tape or string, secure the cap to any convenient plastic body part so it is positioned away from the spark plug.
  - Remove the spark plug from the engine and store it in a safe place. Do not connect the spark plug to the spark plug cap.
  - Pour a tablespoon (15–20 cm<sup>3</sup>) of clean engine oil into the cylinder and cover the spark plug hole with a piece of cloth.
  - Crank the engine several times to distribute the oil.
  - Reinstall the spark plug and spark plug cap.
4. Remove the battery. Store in an area protected from freezing temperatures and direct sunlight.  
Slow charge the battery once a month.
5. Wash and dry the motorcycle. Wax all painted surfaces. Coat chrome with rustinhibiting oil.
6. Lubricate the drive chain (page 65).
7. Inflate the tyres to their recommended pressures. Place the motorcycle on blocks to raise both tyres off the ground.
8. Cover the motorcycle (don't use plastic or other coated materials) and store in an unheated area, free of dampness with a minimum of daily temperature variation.  
Do not store the motorcycle in direct sunlight.

## REMOVAL FROM STORAGE

1. Uncover and clean the motorcycle.  
Change the engine oil if more than 4 months have passed since the start of storage.
2. Charge the battery as required. Install the battery.
3. Drain any excess aerosol rust-inhibiting oil from the fuel tank. Fill the fuel tank with fresh petrol.
4. Perform all Pre-ride Inspection checks (page 35).  
Test ride the motorcycle at low speeds in a safe riding area away from traffic.

# SPECIFICATIONS

## DIMENSIONS

Overall length	2,260 mm (89.0 in)
Overall width	730 mm (28.7 in)
Overall height	1,065 mm (41.8 in)
Wheelbase	1,505 mm (59.1 in)
Ground clearance	148 mm (5.8 in)

## WEIGHT

Dry weight	140 kg (308 lbs)
------------	------------------

## CAPACITIES

Engine oil	(After draining)	1.0 l
	(After disassembly)	1.2 l
Fuel tank		11.2 l
Fuel reserve		2.68 l
Passenger capacity		Operator and one passenger
Maximum weight capacity		126 kg (277 lbs)

## ENGINE

Bore and stroke	63.5 x 62.2 mm (2.49 x 2.44 in)
Compression ratio	9.0 : 1
Displacement	196.9 cm <sup>3</sup>
Spark plug	
Standard	DPR8EA 9 (NGK) or X24EPR U9 (DENSO)
Spark plug cap	0.80 – 0.90 mm (0.031 – 0.035 in)
Idle speed	1,400 ± 100 min (rpm)

## CHASSIS AND SUSPENSION

Caster	31°10'
Trail	117 mm (4.6 in)
Tyre size, front	90/90 – 17 49P
Tyre size, rear	130/90 – 15 M/C 66P

## POWER TRANSMISSION

Primary reduction	3.090
Gear ratio, 1st	2.545
2nd	1.687
3rd	1.280
4th	1.041
5th	0.903
6th	0.814
Final reduction	3.154

## ELECTRICAL

MF Battery	12V – 3.5Ah
Generator	130W/5000 min (rpm)

## LIGHTS

Headlight	12V – 30/30W
Tail/brake light	12V – 5/18W
Turn signal light	12V – 15W x 2
Front	
Rear	12V – 15W x 2
Instrument light	12V – 1.7W x 2
License light bulb	12V – 5W
Neutral indicator light	12V – 1.7W
Turn signal indicator light	12V – 1.7W
High beam indicator light	12V – 1.7W

## FUSE

Main fuse	15A
-----------	-----

## CATALYTIC CONVERTER

This motorcycle is equipped with a catalytic converter.

The catalytic converter contains precious metals that serve as catalysts, promoting chemical reactions to convert the exhaust gasses without affecting the metals.

The catalytic converter acts on HC, CO, and NOx. A replacement unit must be an original Honda part or its equivalent.

The catalytic converter must operate at a high temperature for the chemical reactions to take place. It can set on fire any combustible materials that come near it. Park your motorcycle away from high grasses, dry leaves, or other flammables.

A defective catalytic converter contributes to air pollution, and can impair your engine's performance. Follow these guidelines to protect your motorcycle's catalytic converter.

- Always use unleaded petrol. Even a small amount of leaded petrol can contaminate the catalyst metals, making the catalytic converter ineffective.
- Keep the engine tuned-up.
- Have your motorcycle diagnosed and replaced if it is misfiring, backfiring, stalling or otherwise not running properly.