

 **HONDA**



ST 1300
ST 1300A

OWNER'S MANUAL



**Honda PAN EUROPEAN
ST1300/A**

OWNER'S MANUAL

IMPORTANT INFORMATION

- **OPERATOR AND PASSENGER**

This motorcycle is designed to carry the operator and one passenger. Never exceed the maximum weight capacity as shown on the accessories and loading label.

- **ON-ROAD USE**

This motorcycle is designed to be used only on the road.

- **READ THIS OWNER'S MANUAL CAREFULLY**

Pay special attention to the safety messages that appear throughout the manual. These messages are fully explained in the "A Few Words About Safety" section which appears before the Contents page.

This manual should be considered a permanent part of the motorcycle and should remain with the motorcycle when resold.

**Honda PAN EUROPEAN
ST1300/A
OWNER'S MANUAL**

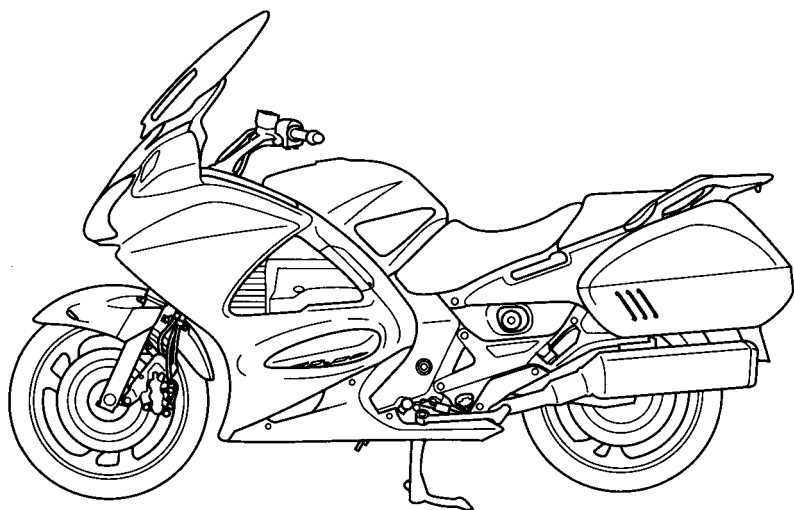

All information in this publication is based on the latest production information available at the time of approval for printing. Honda Motor Co.,Ltd. reserves the right to make changes at any time without notice and without incurring any obligation.

No part of this publication may be reproduced without written permission.

WELCOME

The motorcycle presents you a challenge to master the machine, a challenge to adventure. You ride through the wind, linked to the road by a vehicle that responds to your commands as no other does. Unlike an automobile, there is no metal cage around you. Like an airplane, a pre-ride inspection and regular maintenance are essential to your safety. Your reward is freedom.

To meet the challenges safely, and to enjoy the adventure fully, you should become thoroughly familiar with this owner's manual BEFORE YOU RIDE THE MOTORCYCLE.

As you read this manual, you will find information that is preceded by a **NOTICE** symbol. This information is intended to help you avoid damage to your motorcycle, other property, or the environment.

When service is required, remember that your Honda dealer knows your motorcycle best. If you have the required mechanical "know-how" and tools, your dealer can supply you with an official Honda Shop Manual to help you perform many maintenance and repair tasks.

Pleasant riding, and thank you for choosing a Honda !

- The following codes in this manual indicate each country.
- The illustrations herein are based on the ST1300A type.
- The illustrations herein are based on the ED type.

E	UK	Ireland	
ED	European direct sales		
	Italy	Switzerland	Norway
	Austria	Sweden	Finland
	Holland	Spain	Portugal
	Greece	Denmark	
F	France		
U	Australia	New Zealand	

- The specifications may vary with each locale.

A FEW WORDS ABOUT SAFETY

Your safety, and the safety of others, is very important. And operating this motorcycle safely is an important responsibility.

To help you make informed decisions about safety, we have provided operating procedures and other information on labels and in this manual. This information alerts you to potential hazards that could hurt you or others.

Of course, it is not practical or possible to warn you about all hazards associated with operating or maintaining a motorcycle. You must use your own good judgment.

You will find important safety information in a variety of forms, including:

- **Safety Labels** — on the motorcycle.
- **Safety Messages** — preceded by a safety alert symbol  and one of three signal words: **DANGER**, **WARNING**, or **CAUTION**.

These signal words mean:

⚠ DANGER

You **WILL** be **KILLED** or **SERIOUSLY HURT** if you don't follow instructions.

⚠ WARNING

You **CAN** be **KILLED** or **SERIOUSLY HURT** if you don't follow instructions.

⚠ CAUTION

You **CAN** be **HURT** if you don't follow instructions.

- **Safety Headings** — such as Important Safety Reminders or Important Safety Precautions.
- **Safety Section** — such as Motorcycle Safety.
- **Instructions** — how to use this motorcycle correctly and safely.

This entire manual is filled with important safety information — please read it carefully.

CONTENTS

OPERATION

Page

- 1 MOTORCYCLE SAFETY**
 - 1 IMPORTANT SAFETY INFORMATION
 - 2 PROTECTIVE APPAREL
 - 4 LOAD LIMITS AND GUIDELINES
 - 8 SAFETY LABELS

- 11 PARTS LOCATION**
 - 14 INSTRUMENTS AND INDICATORS
 - 18 MULTI-DISPLAY

- 28 MAJOR COMPONENTS**
(Information you need to operate this motorcycle)
 - 28 REAR SUSPENSION
 - 30 BRAKES
 - 33 CLUTCH
 - 34 COOLANT
 - 36 FUEL
 - 39 ENGINE OIL
 - 40 FINAL DRIVE OIL
 - 41 TUBELESS TYRES

- 46 ESSENTIAL INDIVIDUAL COMPONENTS**
 - 46 IGNITION SWITCH
 - 47 KEYS
 - 48 IMMOBILIZER SYSTEM (HISS)
 - 50 RIGHT HANDLEBAR CONTROLS
 - 51 LEFT HANDLEBAR CONTROLS
 - 52 WINDSCREEN HEIGHT ADJUSTMENT SWITCH
 - 53 HAZARD WARNING SYSTEM SWITCH

Page

54 FEATURES

(Not required for operation)

- 54 STEERING LOCK
- 55 SEAT
- 57 HELMET HOLDERS
- 58 SADDLEBAGS
- 60 FAIRING POCKETS
- 61 WINDSCREEN HEIGHT ADJUSTMENT
- 62 DOCUMENTS
- 63 STORAGE COMPARTMENT FOR U-SHAPED ANTI-THEFT LOCK
- 64 REARVIEW MIRRORS
- 65 HEADLIGHT AIM VERTICAL ADJUSTMENT
- 66 CLIP
- 67 FUEL TANK MAINTENANCE POSITION

69 OPERATION

- 69 PRE-RIDE INSPECTION
- 70 STARTING THE ENGINE
- 72 RUNNING-IN
- 73 RIDING
- 74 BRAKING
- 77 PARKING
- 78 ANTI-THEFT TIPS

CONTENTS

MAINTENANCE

Page

79 MAINTENANCE

79	THE IMPORTANCE OF MAINTENANCE
80	MAINTENANCE SAFETY
81	SAFETY PRECAUTIONS
82	MAINTENANCE SCHEDULE
84	TOOL KIT
85	SERIAL NUMBERS
86	COLOUR LABEL
87	COVER REMOVAL
91	AIR CLEANER
92	ENGINE OIL
97	SPARK PLUGS
99	THROTTLE OPERATION
100	IDLE SPEED
101	COOLANT
102	FINAL DRIVE OIL
103	FRONT AND REAR SUSPENSION INSPECTION
104	SIDE STAND
105	WHEEL REMOVAL
112	BRAKE PAD WEAR
113	BRAKE SYSTEM INSPECTION
114	BATTERY
116	FUSE REPLACEMENT
118	BULB REPLACEMENT

122 CLEANING

126 STORAGE GUIDE

126	STORAGE
127	REMOVAL FROM STORAGE

128 SPECIFICATIONS

130 CATALYTIC CONVERTERS

MOTORCYCLE SAFETY

IMPORTANT SAFETY INFORMATION

Your motorcycle can provide many years of service and pleasure — if you take responsibility for your own safety and understand the challenges that you can meet on the road.

There is much that you can do to protect yourself when you ride. You'll find many helpful recommendations throughout this manual. Following are a few that we consider most important.

Always Wear a Helmet

It's a proven fact: helmets significantly reduce the number and severity of head injuries. So always wear an approved motorcycle helmet and make sure your passenger does the same. We also recommend that you wear eye protection, sturdy boots, gloves, and other protective gear (page 3).

Make Yourself Easy to See

Some drivers do not see motorcycles because they are not looking for them. To make yourself more visible, wear bright reflective clothing, position yourself so other drivers can see you, signal before turning or changing lanes, and use your horn when it will help others notice you.

Ride Within Your Limits

Pushing the limits is another major cause of motorcycle accidents. Never ride beyond your personal abilities or faster than conditions warrant. Remember that alcohol, drugs, fatigue and inattention can significantly reduce your ability to make good judgements and ride safely.

Don't Drink and Ride

Alcohol and riding don't mix. Even one drink can reduce your ability to respond to changing conditions, and your reaction time gets worse with every additional drink. So don't drink and ride, and don't let your friends drink and ride either.

Keep Your Bike in Safe Condition

For safe riding, it's important to inspect your motorcycle before every ride and perform all recommended maintenance. Never exceed load limits, and only use accessories that have been approved by Honda for this motorcycle. See page 5 for more details.

MOTORCYCLE SAFETY

PROTECTIVE APPAREL

For your safety, we strongly recommend that you always wear an approved motorcycle helmet, eye protection, boots, gloves, long pants, and a long-sleeved shirt or jacket whenever you ride. Although complete protection is not possible, wearing proper gear can reduce the chance of injury when you ride.

Following are suggestions to help you choose proper gear.

WARNING

Not wearing a helmet increases the chance of serious injury or death in a crash.

Be sure you and your passenger always wear a helmet, eye protection and other protective apparel when you ride.

Helmets and Eye Protection

Your helmet is your most important piece of riding gear because it offers the best protection against head injuries. A helmet should fit your head comfortably and securely. A bright-coloured helmet can make you more noticeable in traffic, as can reflective strips.

An open-face helmet offers some protection, but a full-face helmet offers more. Always wear a face shield or goggles to protect your eyes and help your vision.

Additional Riding Gear

In addition to a helmet and eye protection, we also recommend:

- Sturdy boots with non-slip soles to help protect your feet and ankles.
- Leather gloves to keep your hands warm and help prevent blisters, cuts, burns and bruises.
- A motorcycle riding suit or jacket for comfort as well as protection. Bright-coloured and reflective clothing can help make you more noticeable in traffic. Be sure to avoid loose clothes that could get caught on any part of your motorcycle.

MOTORCYCLE SAFETY

LOAD LIMITS AND GUIDELINES

Your motorcycle has been designed to carry you, one passenger, cargo and accessories. When you add cargo or carry a passenger, you may feel some difference during acceleration and braking. But so long as you keep your motorcycle well-maintained, with good tyres and brakes, you can safely carry loads within the limits and guidelines given below.

However, exceeding the weight limit or carrying an unbalanced load can seriously affect your motorcycle's handling, braking and stability. Non-Honda accessories, improper modifications, and poor maintenance can also reduce your safety margin.

The following pages give more specific information on loading, accessories and modifications.

Loading

How much weight you put on your motorcycle, and how you load it, are important to your safety. Anytime you ride with a passenger or cargo you should be aware of the following information.

WARNING

Overloading or improper loading can cause a crash and you can be seriously hurt or killed.

Follow all load limits and other loading guidelines in this manual.

Load Limits

Following are the load limits for your motorcycle:

Maximum weight capacity: = 196 kg (432 lbs)

Includes the weight of the rider,
passenger, all cargo and all accessories

Putting too much weight in individual storage compartments can also affect stability and handling. So be sure to stay within the limits given below:

Maximum cargo weight: = 31 kg (68 lbs)

includes following maximum
compartment weights:

rear carrier = 9.0 kg (20.0 lbs)

each saddlebag = 9.0 kg (20.0 lbs)

each fairing pocket = 2.0 kg (4.5 lbs)

The weight of added accessories will reduce the maximum cargo weight you can carry.

Loading Guidelines

Improperly loading your motorcycle can affect its stability and handling. Even if your motorcycle is properly loaded, you should ride at reduced speeds and never exceed 130 km/h (80 mph) when carrying cargo.

Follow these guidelines whenever you carry a passenger or cargo:

- Check that both tyres are properly inflated (page 41).
- If you change your normal load, you may need to adjust your rear suspension settings (page 28) and your headlight (page 65).
- To prevent loose items from creating a hazard, make sure that storage lids are properly closed and that any other cargo is securely tied down before you ride away.

MOTORCYCLE SAFETY

- Cargo weight should be carried as low and as close to the centre of a motorcycle as possible. When loading your motorcycle, try to pack heavier items in the saddlebags and put lighter, bulkier items in the travel trunk. If you must carry heavy items in the trunk, put them as far forward as you can.
- Balance cargo weight evenly on both sides. When loading the saddlebags, for example, be sure the weight in each bag is about the same.

Accessories and Modifications

Modifying your motorcycle or using non-Honda accessories can make your motorcycle unsafe. Before you consider making any modifications or adding an accessory, be sure to read the following information.

WARNING

Improper accessories or modifications can cause a crash in which you can be seriously hurt or killed.

Follow all instructions in this owner's manual regarding accessories and modifications.

Accessories

We strongly recommend that you use only Honda Genuine Accessories that have been specifically designed and tested for your motorcycle. Because Honda cannot test all other accessories, you must be personally responsible for proper selection, installation and use of non-Honda accessories. Check with your dealer for assistance and always follow these guidelines:

- Make sure the accessory does not obscure any lights, reduce ground clearance and banking angle, limit suspension travel or steering travel, alter your riding position or interfere with operating any controls.

-
- Be sure electrical equipment does not exceed the motorcycle's electrical system capacity (page 129). A blown fuse can cause a loss of lights or engine power.
 - Do not pull a trailer or sidecar with your motorcycle. This motorcycle was not designed for these attachments, and their use can seriously impair your motorcycle's handling.

Modifications

We strongly advise you not to remove any original equipment or modify your motorcycle in any way that would change its design or operation. Such changes could seriously impair your motorcycle's handling, stability and braking, making it unsafe to ride.

Removing or modifying your lights, mufflers, emission control system or other equipment can also make your motorcycle illegal.

MOTORCYCLE SAFETY

SAFETY LABELS

The following pages show the locations of safety labels on your motorcycle. Some labels warn you of potential hazards that could cause serious injury. Others provide important safety information. Read these labels carefully and don't remove them.

If a label comes off or becomes hard to read, contact your Honda dealer for a replacement.

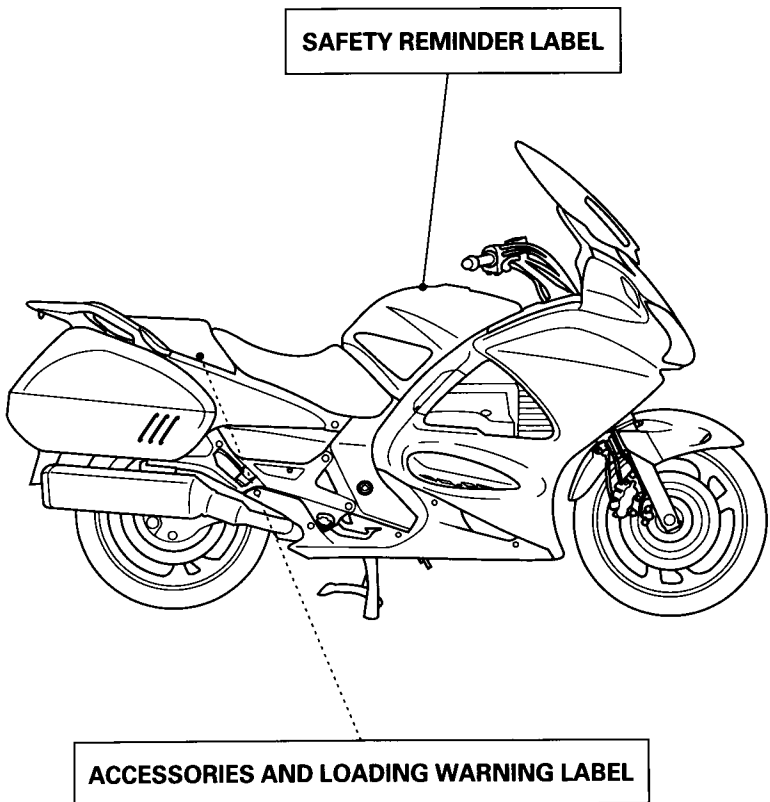

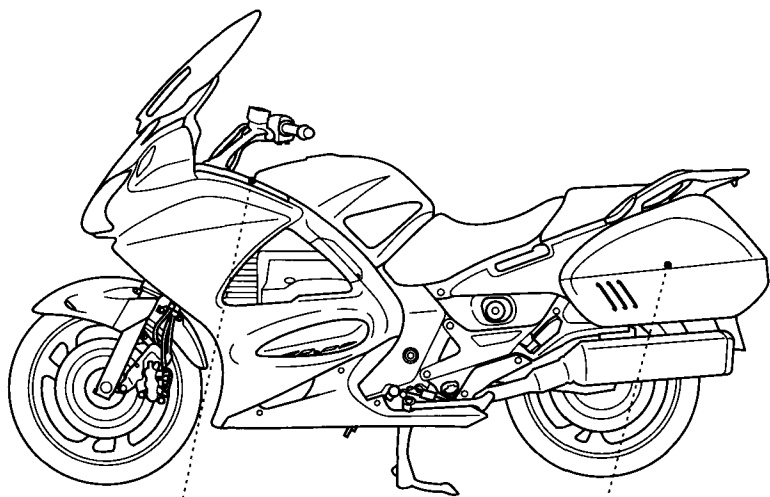

CARGO LIMIT

2.0kg / 4.5lbs

CARGO LIMIT

9.0kg / 20.0lbs

MOTORCYCLE SAFETY

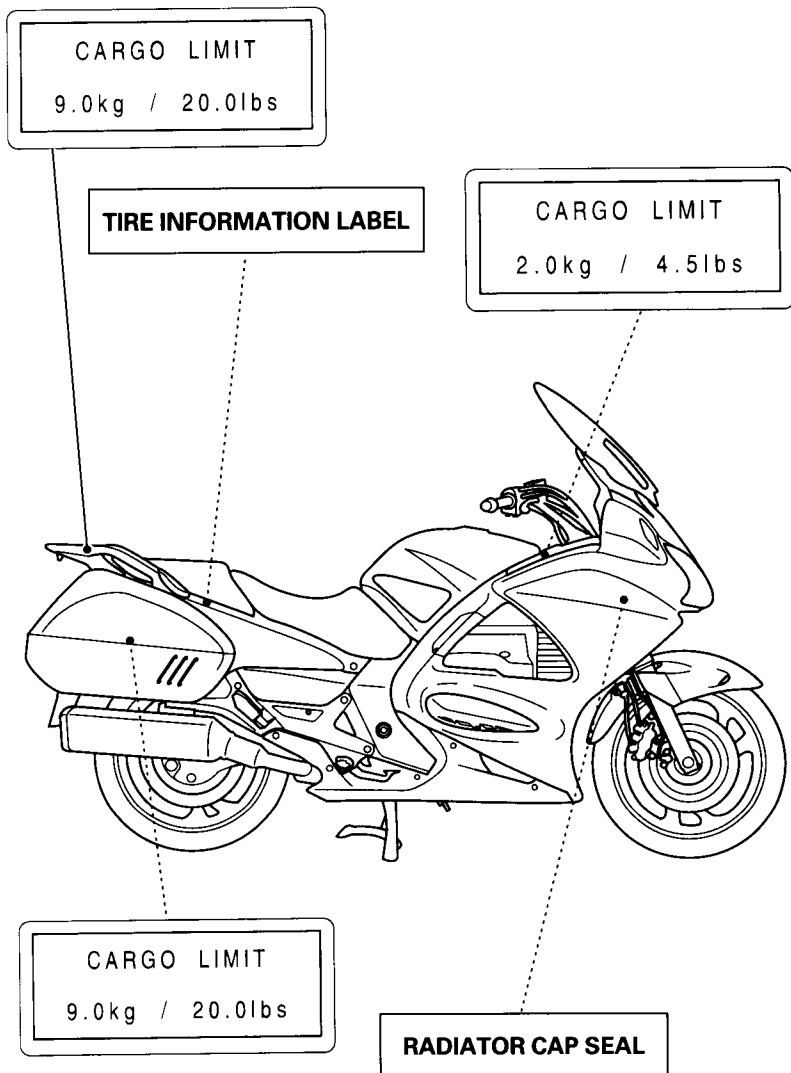

PARTS LOCATION

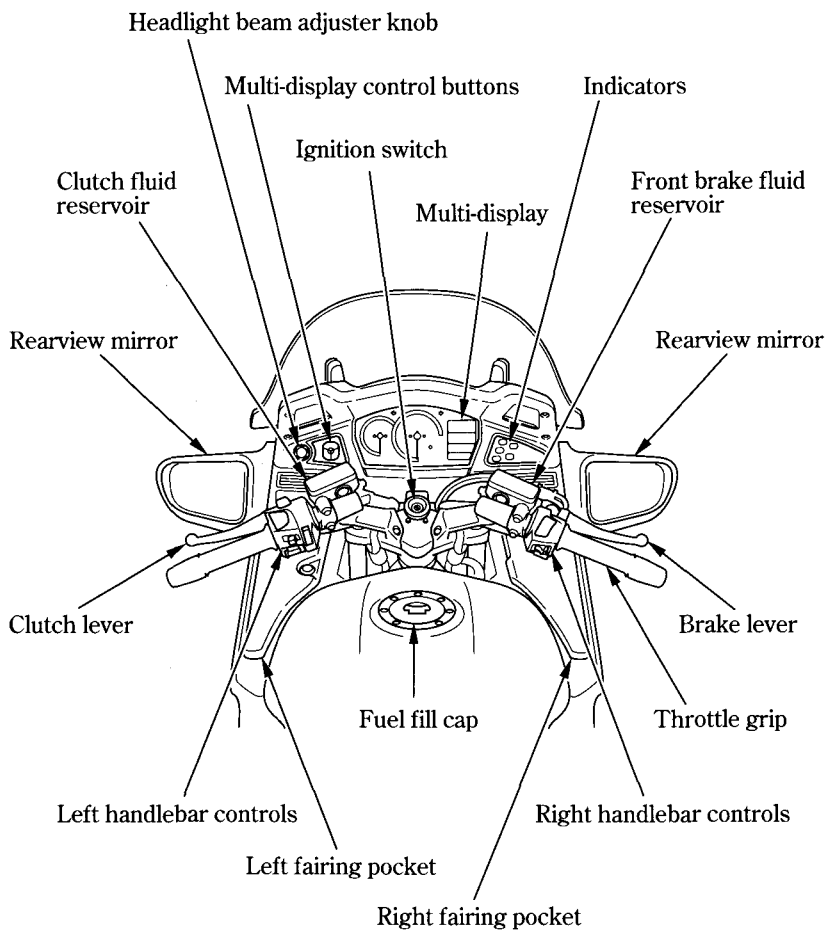

PARTS LOCATION

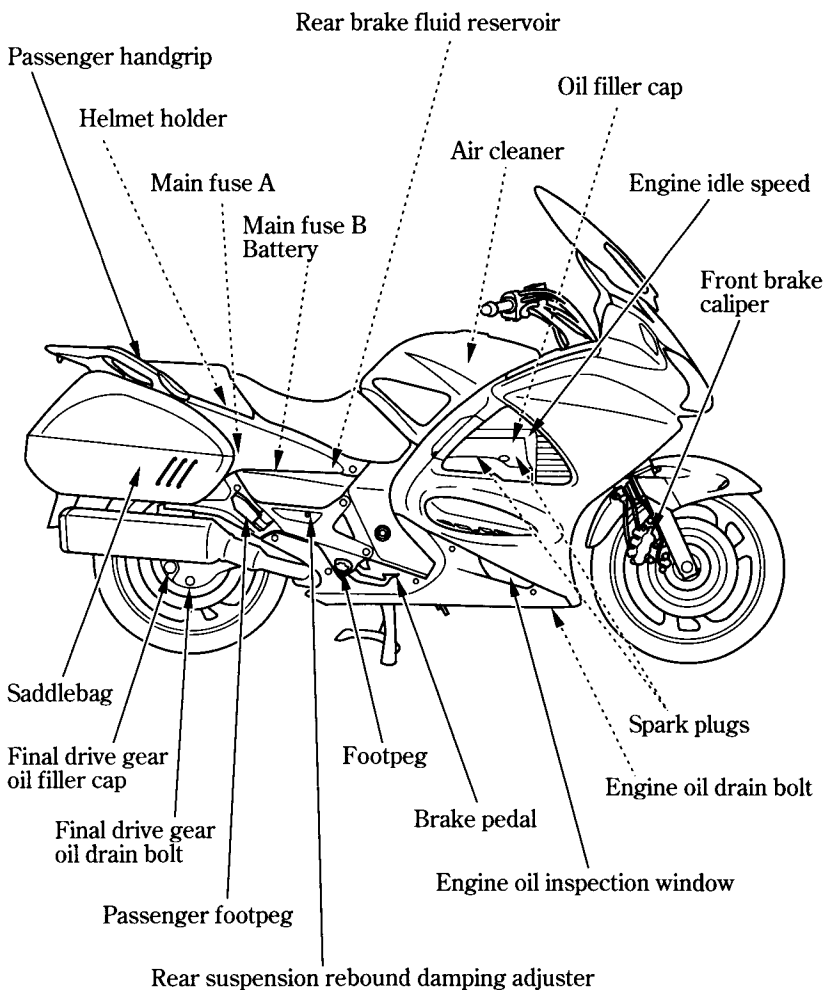

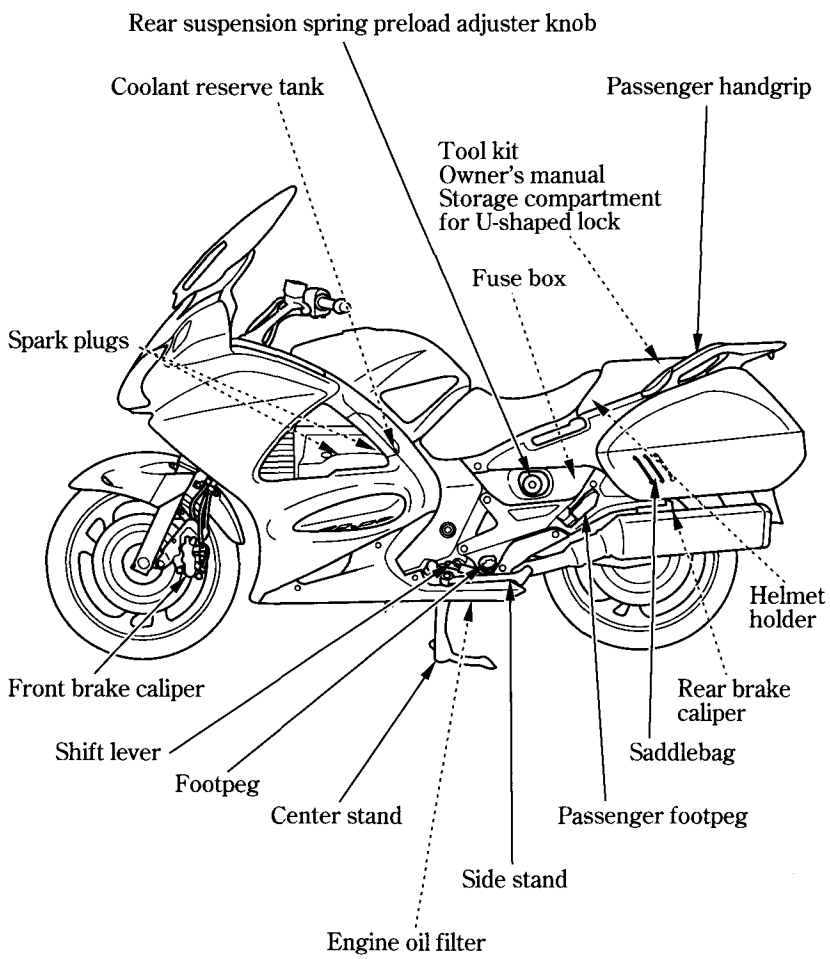

PARTS LOCATION

INSTRUMENTS AND INDICATORS

The indicators are contained in the instrument panel. Their functions are described in the tables on the following pages.

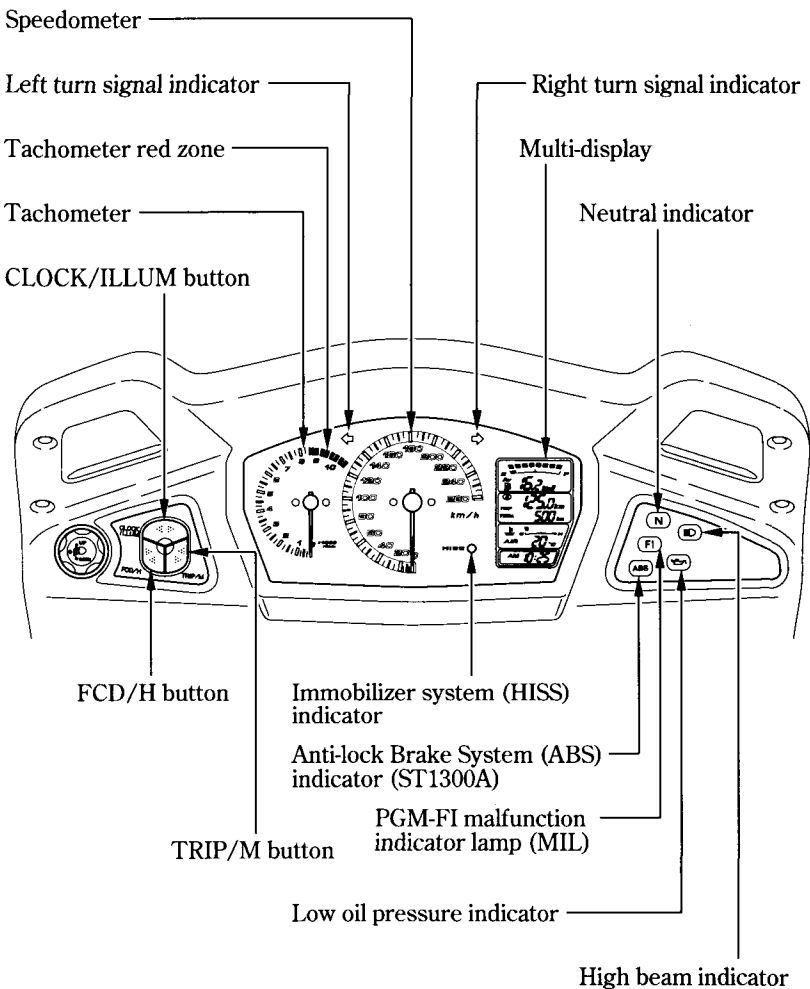



Speedometer

Shows riding speed.

This shows your speed in kilometers per hour (km/h) and/or miles per hour (mph) depending on the type.



Tachometer

Shows engine speed in revolutions per minute.



Tachometer red zone

Never allow the tachometer needle to enter the red zone, even after the engine has been broken in.

NOTICE

Running the engine beyond recommended maximum engine speed (the beginning of the tachometer red zone) can damage the engine.



Turn signal indicators (green)

Flashes when a turn signal operates.



Neutral indicator (green)

Lights when the transmission is in neutral.

PARTS LOCATION



Low oil pressure indicator (red)

Lights when the engine oil pressure is below normal operating range. Should light when ignition switch is ON and engine is not running. Should go out when the engine starts, except for occasional flickering at or near idling speed when engine is warm.

NOTICE

Running the engine with insufficient oil pressure may cause serious engine damage.



PGM-FI malfunction indicator lamp (MIL) (red)

Lights when there is any abnormality in the PGM-FI (Programmed Fuel Injection) system. Should also light for a few seconds and then go off when the ignition switch is turned ON and engine stop switch is at \odot (RUN). If the indicator comes on at any other time, reduce speed and take the motorcycle to a Honda dealer as soon as possible.



Anti-lock Brake System
(ABS) indicator
(red)
(ST1300A)

This light normally comes on when the ignition is turned ON, and goes off after you ride the motorcycle at speed above 10 km/h (6 mph). If there is a problem with the Anti-lock Brake System, this light flashes and remains on (page 76).



High beam indicator (blue)

Lights when the headlight is on high beam.



Immobilizer system
(HISS) indicator
(red)

This indicator lights for a few seconds when the ignition switch is turned ON and the engine stop switch is at  (RUN). It will then go off if the properly-coded key has been inserted. If an improperly-coded key has been inserted, the indicator will remain on and the engine will not start (page 48).

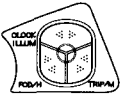

CLOCK/ILLUM button

Use this button for the following purposes.

- To adjust time
- To adjust display illumination
- To switch blinking of the immobilizer system (HISS) indicator

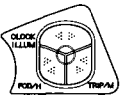

FCD/H button

Use this button for the following purposes.

- To adjust time
- To select and reset the fuel mileage meter
- To change the mileage units for the odometer/tripmeter and fuel consumption meter

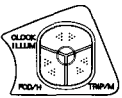

TRIP/M button

Use this button for the following purposes.

- To adjust time
- To select and reset the tripmeter

PARTS LOCATION

MULTI-DISPLAY

Your motorcycle is equipped with a Multi-display that presents various displays. This section explains display functions and operations.

Initial Display

When the ignition switch is turned ON, the display will temporarily show all the modes and digital segments so you can make sure the liquid crystal display is functioning properly. (Except digital clock)

The unit "mile/ℓ" and "mile" will be displayed only for E type.

Digital clock and tripmeter will reset if the battery is disconnected.

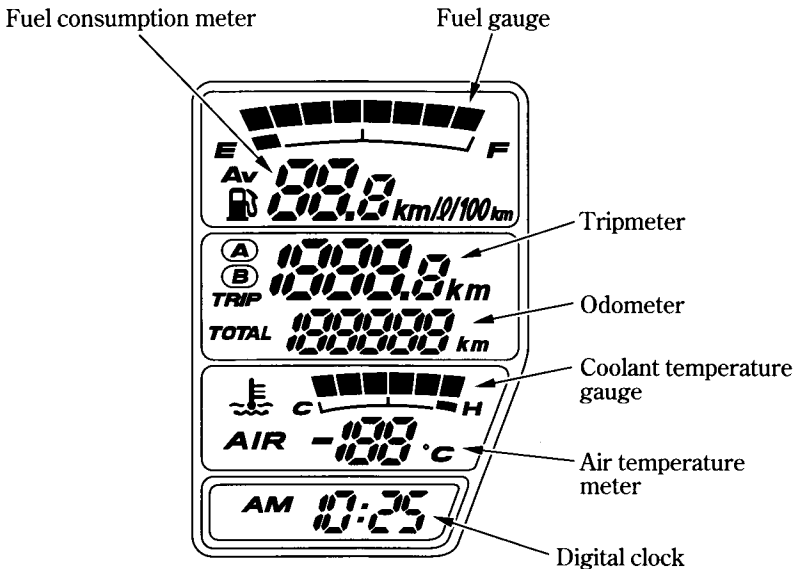

Fuel Gauge

The fuel gauge liquid crystal display shows the approximate fuel supply available in a graduated display. When the segment F goes on, the fuel tank capacity including reserve is:

29.0 l (7.66 US gal , 6.38 Imp gal)

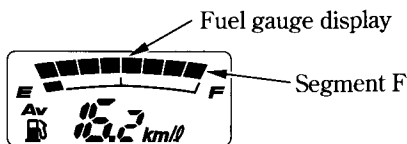

When segment E flashes, fuel will be low and you should refill the tank as soon as possible. The amount of fuel left in the tank with the vehicle set upright is approximately:

5.0 l (1.32 US gal , 1.10 Imp gal)

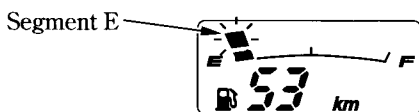

Coolant Temperature Gauge

When the segment begins to move above the C (Cold) mark, the engine is warm enough for the motorcycle to be ridden. The normal operating temperature range is within the section between the H and C marks.

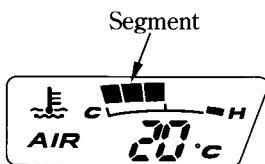

If the segment H flashes, stop the engine and check the reserve tank coolant level. Read pages 34 – 35 and do not ride the motorcycle until the problem has been corrected.

NOTICE

Exceeding maximum running temperature may cause serious engine damage.

PARTS LOCATION

Air Temperature Meter

Air temperature meter shows air temperature digitally.

Temperature Display

Below -11°C	"— —" is displayed.
Between: -10°C — 50°C	Actual air temperature is indicated.
Above 50°C	The display will remain and blink " 50°C ".

The temperature sensor is located in the fairing. The temperature reading can be affected by heat reflecting from the road surface, engine heat, and the exhaust from surrounding traffic. This can cause an error in the temperature reading when your speed is under 30 km/h (19 mph).



Fuel Consumption Meter

The fuel consumption meter allows indication of the available driving distance, the amount of remaining fuel, the current fuel consumption and the average fuel consumption. Briefly pressing the FCD/H button changes the indication as described below. The available driving distance and the amount of remaining fuel are indicated when the fuel in the fuel tank becomes 5 liters or less.

《When more than 5 liters》

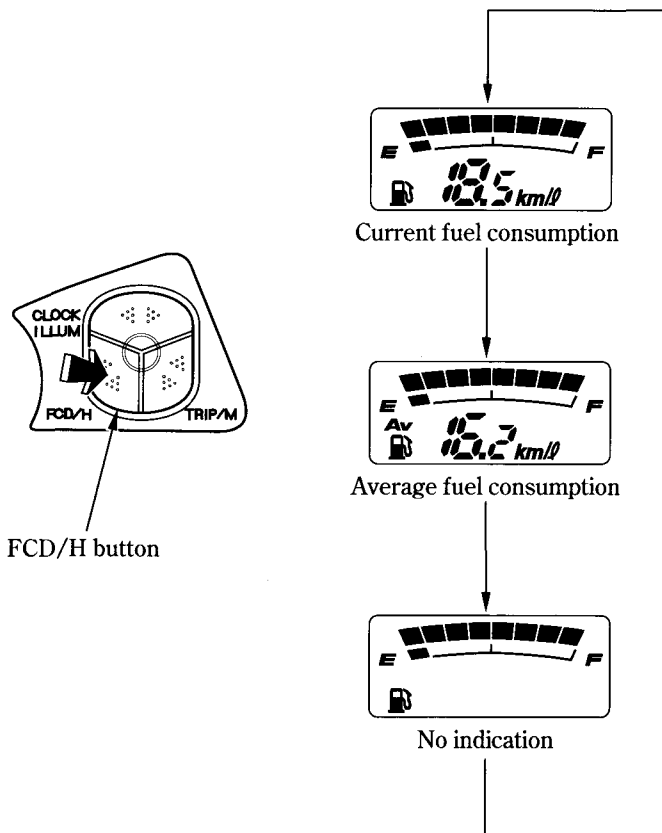

PARTS LOCATION

《When less than 5 liters》

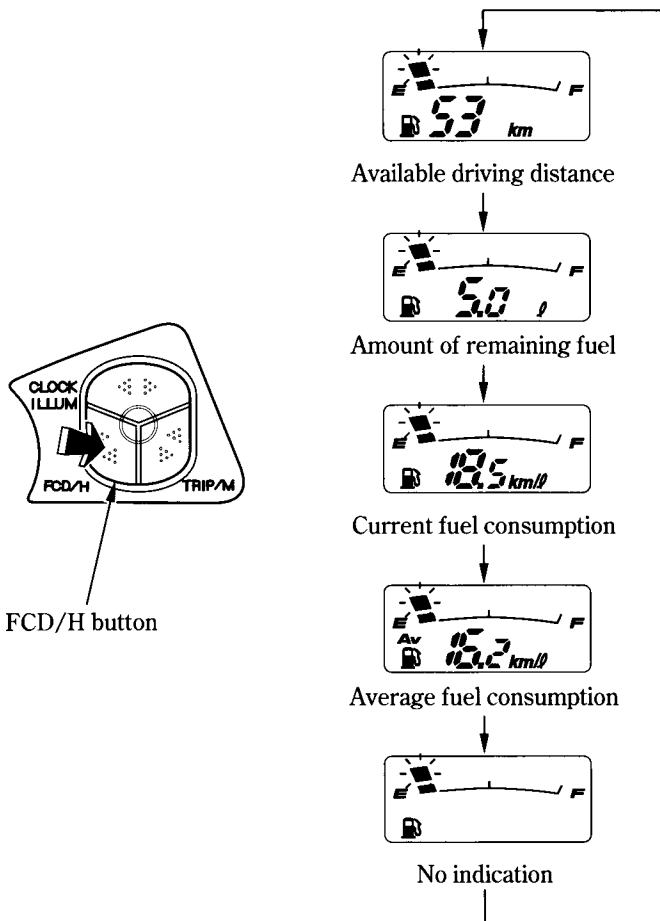

- When the remaining fuel becomes 5 liters or less, the indication automatically changes to the available driving distance.
(Except no indication)
- When the battery terminal is disconnected, the available driving distance, the amount of remaining fuel and the average fuel consumption memories will be reset.
- When the battery terminal is disconnected with 5 liters or less fuel remaining, the available driving distance and the amount of remaining fuel may be shown inaccurately in some cases.

Current Fuel Consumption

Indicates the momentary fuel consumption of each 15 seconds during engine operation. With motorcycle speed 5 km/h or below “- -” is displayed.

The indicated fuel consumption may differ from the actual fuel consumption.

The E type uses mile/ℓ or km/ℓ, the ED, F and U type in km/ℓ or ℓ/100 km.

When “- -” blinks, go to your Honda dealer.

Current fuel consumption



Average Fuel Consumption

The average fuel consumption after reset until that moment is indicated every 15 seconds.

The indicated fuel consumption may differ from the actual fuel consumption.

The E type uses mile/ℓ or km/ℓ, the ED, F and U type in km/ℓ or ℓ/100 km.

When “- -” blinks, go to your Honda dealer.

Average fuel consumption



To reset average fuel consumption:

Press and hold the FCD/H button for more than 2 seconds with the display in the average fuel consumption.

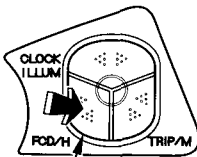

FCD/H button



PARTS LOCATION

Available Driving Distance

When the amount of remaining fuel becomes less than 5 liters, the estimated allowable distance is indicated.

The E type uses mile or km, and others use km.

When the amount of remaining fuel becomes less than 2 liters, “-.” will be indicated.

The indicated available driving distance is by calculation depending on the driving conditions, and the indicated figure may not always be the actual allowable distance. When the fuel gauge near to E or when E segment blinks, fill fuel promptly.



Remaining Fuel

When the amount of remaining fuel becomes less than 5 liters, the estimated amount of remaining fuel is indicated.

When the amount of remaining fuel becomes less than 2 liters, “-.” will be indicated.

The amount of remaining fuel is calculated from the driving conditions.

The indicated amount of remaining fuel may be different from the actual amount. When the fuel gauge near to E or when E segment blinks, fill fuel promptly.

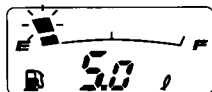

Odometer/Tripmeter

- ODO (Odometer) — shows the total miles (For E type) or kilometer (Except E type) ridden.
- TRIP (Tripmeter) — shows the number of miles (For E type) or kilometer (Except E type) ridden.

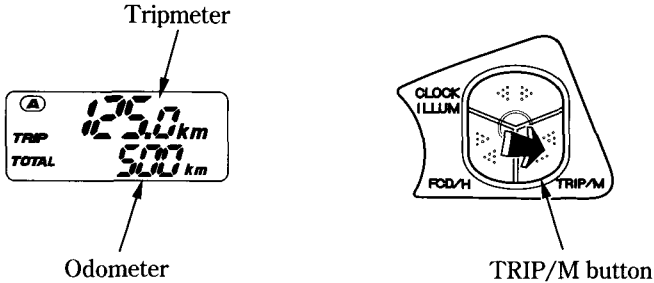

The tripmeter will show mileage in two sub modes, “tripmeter A” and “tripmeter B.”

Press the TRIP/M button to select the “tripmeter A” or “tripmeter B” mode.

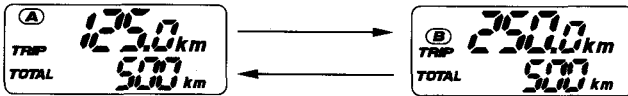

To reset the tripmeter, press and hold the TRIP/M button for more than 2 seconds with the display in the “tripmeter A” or “tripmeter B” mode.

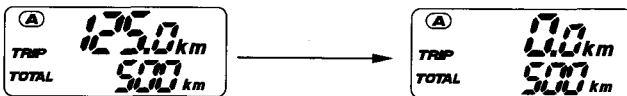

PARTS LOCATION

Digital Clock

The display shows the hour and minute.

To adjust the time:

1. Turn the ignition switch to ON or ACC.
2. Press and hold the CLOCK/ILLUM button for more than 2 seconds. The clock will be set in the adjust mode with the display flashing.
3. To set the hour, press and release the FCD/H button until the desired hour appears.
 - Quick setting — press and hold the FCD/H button until the desired hour appears.
4. To set the minute, press and release the TRIP/M button until the desired minute appears.
 - Quick setting — press and hold the TRIP/M button until the desired minute appears.
5. To end the adjustment, press the CLOCK/ILLUM button after the last adjustment, or turn the ignition switch OFF.

Wait approximately 5 seconds; the display will stop flashing automatically. If the ignition switch is turned off during the time adjustment mode, the blinking function of the immobilizer system (HISS) indicator will be altered.

After turning ignition switch OFF, the clock will display for 10 days.

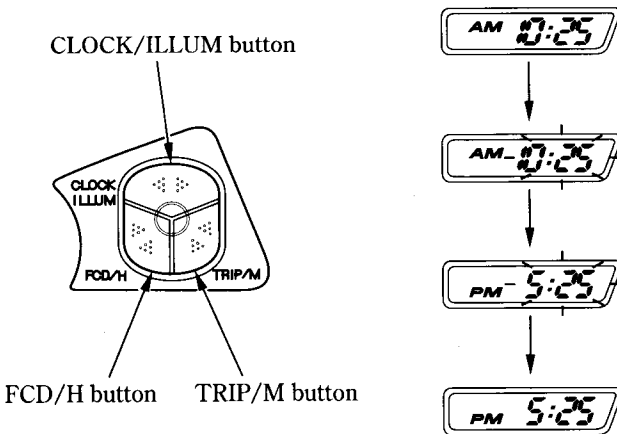

Mileage and Fuel Consumption Unit Change

The odometer/tripmeter displays either “km” or “mile”. (E type only)

The current/average fuel consumption meter displays either “km/ℓ” or “mile/ℓ” (E type)/“km/ℓ” or “ℓ/100 km” (ED, F and U type).

Press the FCD/H button to get the fuel consumption meter display shown below.

Press and hold the FCD/H button for more than 2 seconds to select.

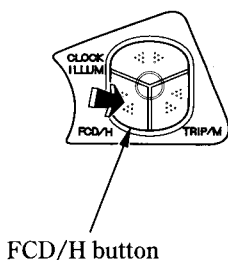

No indication

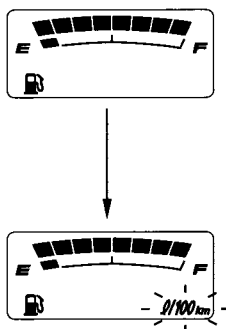

Display Illumination Adjustment

The brightness of a display can be adjusted in three stages.

To adjust the brightness of the display, press the CLOCK/ILLUM button.

CLOCK/ILLUM button

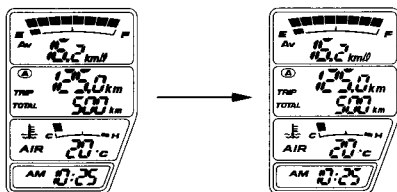
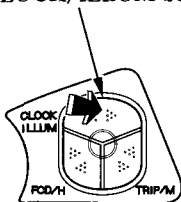

MAJOR COMPONENTS

(Information you need to operate this motorcycle)

REAR SUSPENSION

Rebound Damping:

To reduce (SOFT) :

Turn the adjuster counterclockwise toward SOFT for a light load and smooth road condition.

To increase (HARD) :

Turn the adjuster clockwise toward HARD for a firmer ride and rough road condition.

To adjust the adjuster to the standard position, proceed as follows :

1. Turn the damping adjuster clockwise until it will no longer turn (lightly seats). This is the full hard setting.
2. The adjuster is set in the standard position when the adjuster is turned counterclockwise approximately 1 turn so that its punch mark aligns with the reference punch mark.

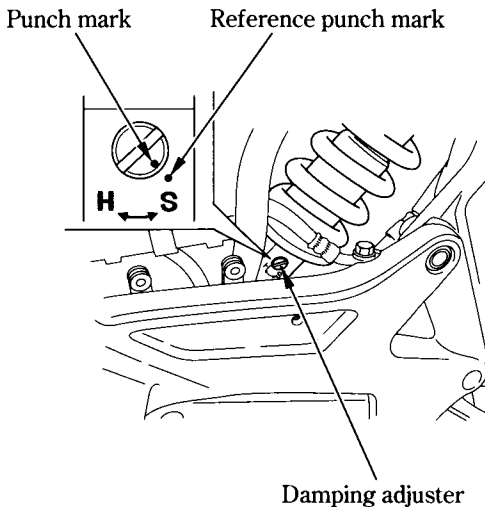

Spring Preload:

The spring preload adjuster knob has 35 spring preload positions (clicks) or more for different load or riding conditions.

To adjust the spring preload, turn the adjuster knob.

To reduce (LOW) :

Turn the adjuster counterclockwise toward LOW for a light load and smooth road condition.

To increase (HIGH) :

Turn the adjuster clockwise toward HIGH for a firmer ride and rough road condition.

To adjust to the standard position:

Turn the spring preload adjuster knob counterclockwise until it will no longer turn (lightly seats). This is the full LOW setting. Turn the adjuster clockwise by 7 clicks. At that position, the end of the adjuster knob should be aligned with the indicator line.

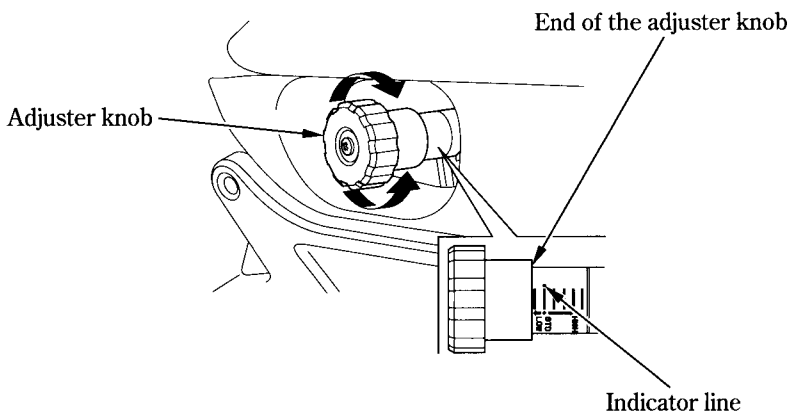

The rear shock absorber assembly includes a damper unit that contains high pressure nitrogen gas. Do not attempt to disassemble or service the damper; it cannot be rebuilt and must be replaced when worn out. Disposal should only be done by your Honda dealer. The instructions found in this owner's manual are limited to adjustment of the shock assembly only.

MAJOR COMPONENTS

(Information you need to operate this motorcycle)

BRAKES

Both the front and rear brakes are the hydraulic disc types.

As the brake pads wear, the brake fluid level drops.

There are no adjustments to perform, but fluid level and pad wear must be inspected periodically. The system must be inspected frequently to ensure there are no fluid leaks. If the control lever or pedal free travel becomes excessive and the brake pads are not worn beyond the recommended limit (page 112), there is probably air in the brake system and it must be bled. See your Honda dealer for this service.

Front Brake Fluid Level:

With the motorcycle in an upright position, check the fluid level. It should be above the LOWER level mark. If the level is at or below the LOWER level mark, check the brake pads for wear (page 112).

Worn pads should be replaced. If the pads are not worn, have your brake system inspected for leaks.

The recommended brake fluid is Honda DOT 4 brake fluid from a sealed container, or an equivalent.

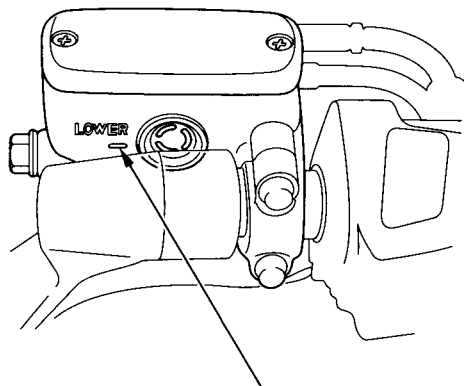

LOWER level mark

The distance between the tip of the brake lever and the grip can be adjusted.

1. Turn the adjuster dial while pushing the brake lever forward.
2. Align the index mark on the brake lever with the numbers on the adjuster dial.
3. Apply the brake, release it, then spin the wheel and check that it rotates freely. Repeat this procedure several times.

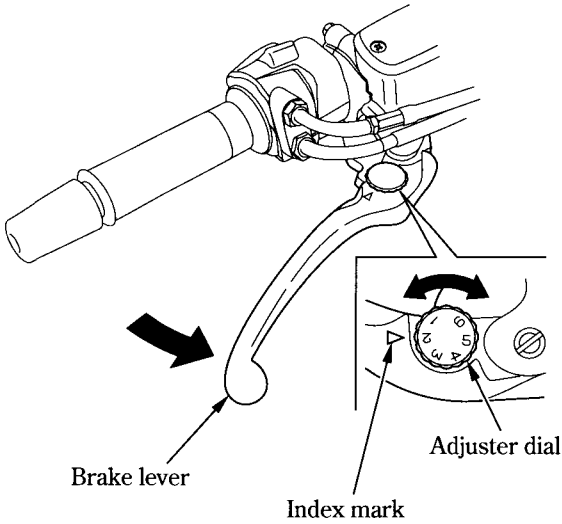

Other Checks:

Make sure there are no fluid leaks. Check for deterioration or cracks in the hoses and fittings.

MAJOR COMPONENTS

(Information you need to operate this motorcycle)

Rear Brake Fluid Level:

The reserve tank is located below the seat.

Remove the front and rear seat and right side cover (pages 55 , 88).

With the motorcycle in an upright position, check the fluid level. It should be between the UPPER and LOWER level marks. If the level is at or below the LOWER level mark, check the brake pads for wear (page 112).

Worn pads should be replaced. If the pads are not worn, have your brake system inspected for leaks.

The recommended brake fluid is Honda DOT 4 brake fluid from a sealed container, or an equivalent.

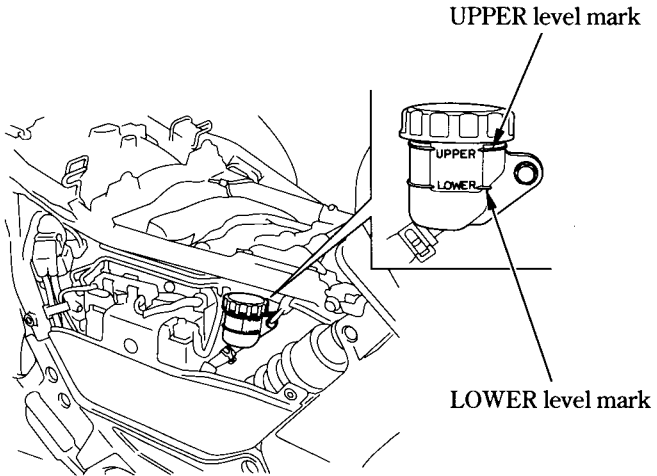

Other Checks:

Make sure there are no fluid leaks. Check for deterioration or cracks in the hoses and fittings.

CLUTCH

This motorcycle has a hydraulically actuated clutch. There are no adjustments to perform, but the clutch system must be inspected periodically for fluid level and leakage.

If the motorcycle creeps or stalls when shifted into gear, or if the clutch slips, causing acceleration to lag behind engine speed, there is probably air in the clutch system and it must be bled out. See your Honda dealer for this service.

Fluid Level:

Check that the fluid level is above the LOWER level mark. If the fluid level is near the LOWER level mark, it indicates fluid leakage. See your Honda dealer for repair.

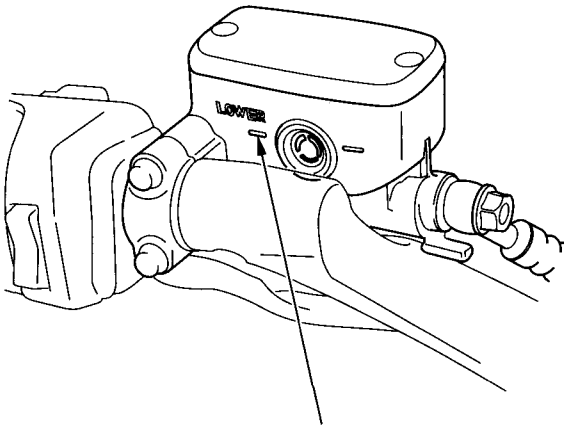

LOWER level mark

Other Checks:

Make sure there are no fluid leaks. Check for deterioration or cracks in the hoses and fittings.

MAJOR COMPONENTS

(Information you need to operate this motorcycle)

COOLANT

Coolant Recommendation

The owner must properly maintain the coolant to prevent freezing, overheating, and corrosion. Use only high quality ethylene glycol antifreeze containing corrosion protection inhibitors specifically recommended for use in aluminum engines. (SEE ANTIFREEZE CONTAINER LABEL).

Use only low-mineral drinking water or distilled water as a part of the antifreeze solution. Water that is high in mineral content or salt may be harmful to the aluminum engine.

Using coolant with silicate inhibitors may cause premature wear of water pump seals or blockage of radiator passages.

Using tap water may cause engine damage.

The factory provides a 50/50 solution of antifreeze and distilled water in this motorcycle. This coolant solution is recommended for most operating temperatures and provides good corrosion protection. A higher concentration of antifreeze decreases the cooling system performance and is recommended only when additional protection against freezing is needed. A concentration of less than 40/60 (40% antifreeze) will not provide proper corrosion protection. During freezing temperatures, check the cooling system frequently and add higher concentrations of antifreeze (up to a maximum of 60% antifreeze) if required.

Inspection

The reserve tank is located below the maintenance lid.

Remove the left maintenance lid (page 88).

Check the coolant level in the reserve tank while the engine is at normal operating temperature. Add coolant to the reserve tank as required to bring coolant level to the UPPER level mark. Always add coolant to the reserve tank. Do not attempt to add coolant by removing the radiator cap.

If the reserve tank is empty, or if coolant loss is excessive, check for leaks and see your Honda dealer for repair.

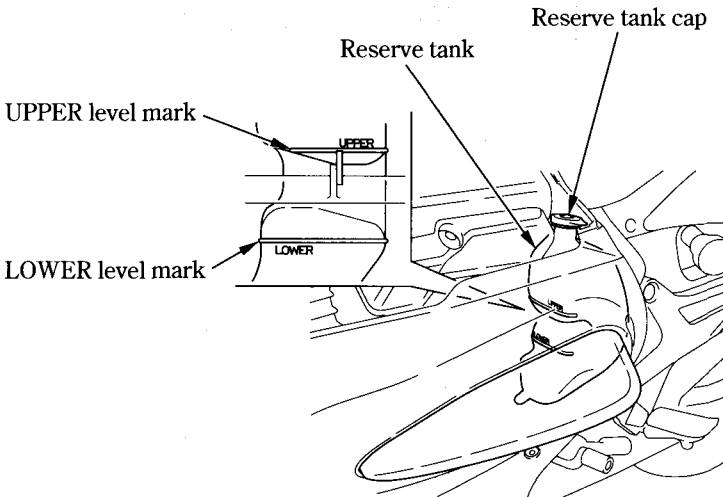

MAJOR COMPONENTS

(Information you need to operate this motorcycle)

FUEL

Fuel Tank

The fuel tank capacity including the reserve supply is:

29.0 ℓ (7.66 US gal , 6.38 Imp gal)

To open the fuel fill cap, insert the ignition key and turn it clockwise. The fuel fill cap is hinged and will lift up.

Do not overfill the tank. There should be no fuel in the filler neck.

After refueling, to close the fuel fill cap, push the fuel fill cap into the filler neck until it snaps closed and locks. Remove the key.

⚠ WARNING

Petrol is highly flammable and explosive. You can be burned or seriously injured when handling fuel.

- Stop the engine and keep heat, sparks, and flame away.
- Refuel only outdoors.
- Wipe up spills immediately.

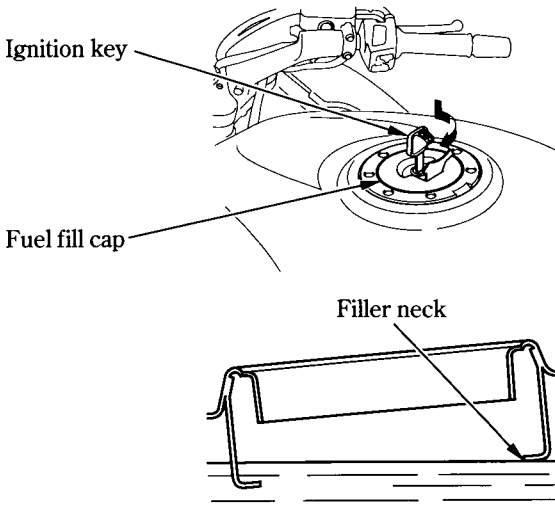

Use premium unleaded petrol with a research octane number of 95 or higher. The use of leaded petrol will cause premature damage to the catalytic converters.

Occasionally you may experience light spark knock while operating under heavy loads. This is no cause for concern, it simply means your engine is operating efficiently.

NOTICE

If “spark knock” or “pinking” occurs at a steady engine speed under normal load, change brands of petrol. If spark knock or pinking persists, consult your Honda dealer. Failure to do so is considered misuse, and damage caused by misuse is not covered by Honda’s Limited Warranty.

MAJOR COMPONENTS

(Information you need to operate this motorcycle)

Petrol Containing Alcohol

If you decide to use a petrol containing alcohol (gasohol), be sure it's octane rating is at least as high as that recommended by Honda. There are two types of "gasohol": one containing ethanol, and the other containing methanol. Do not use petrol that contains more than 10 % ethanol. Do not use petrol containing methanol (methyl or wood alcohol) that does not also contain cosolvents and corrosion inhibitors for methanol. Never use petrol containing more than 5 % methanol, even if it has cosolvents and corrosion inhibitors.

Fuel system damage or engine performance problems resulting from the use of fuels that contain alcohol is not covered under the warranty. Honda cannot endorse the use of fuels containing methanol since evidence of their suitability is as yet incomplete.

Before buying fuel from an unfamiliar station, try to find out if the fuel contains alcohol. If it does, confirm the type and percentage of alcohol used. If you notice any undesirable operating symptoms while using a petrol that contains alcohol, or one that you think contains alcohol, switch to a petrol that you know does not contain alcohol.

ENGINE OIL

Engine Oil Level Check

Check the engine oil level each day before riding the motorcycle. The level must be maintained between the upper and lower level marks in the inspection window.

To Check the Oil Level:

1. Start the engine and let it idle for 3–5 minutes. Make sure the low oil pressure indicator goes off. If the indicator remains flashing, stop the engine immediately.
2. Stop the engine and put the motorcycle on its center stand on level ground.
3. After 2–3 minutes, check that the oil level is between the upper and lower level marks in the inspection window.
4. If required, remove the right maintenance lid (page 88), overhead cover (page 90) and oil filler cap and add the specified oil up to the upper level mark. Do not overfill.
5. Reinstall the oil filler cap, overhead cover and right maintenance lid. Check for oil leaks.

NOTICE

Running the engine with insufficient oil pressure may cause serious engine damage.

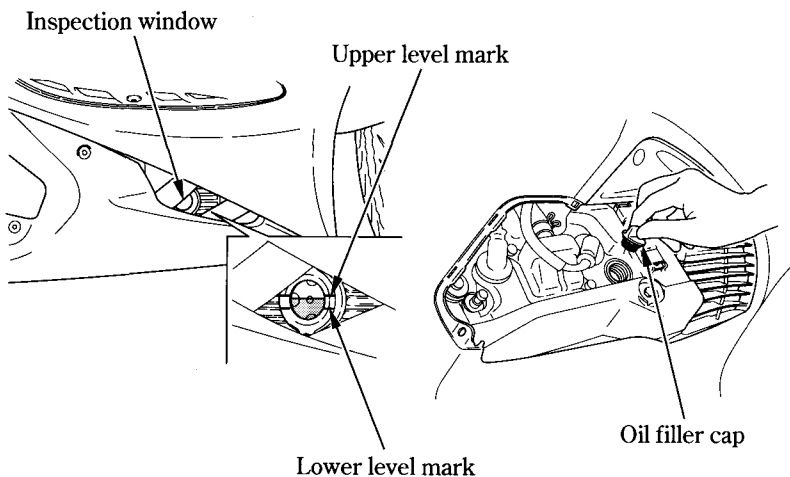

MAJOR COMPONENTS

(Information you need to operate this motorcycle)

FINAL DRIVE OIL

Oil Level Check

Check the final drive oil level when specified by the maintenance schedule (page 83).

1. Place the motorcycle on its center stand on a firm, level surface.
2. Remove the oil filler cap.
3. Check the oil level. It should be flush with the lower edge of the oil filler hole.
4. If the level is low, check for oil leaks. Add the recommended oil through the oil filler hole until it reaches the lower edge of the opening.
5. Install the oil filler cap.

Recommended Oil:

HYPOID GEAR OIL SAE 80

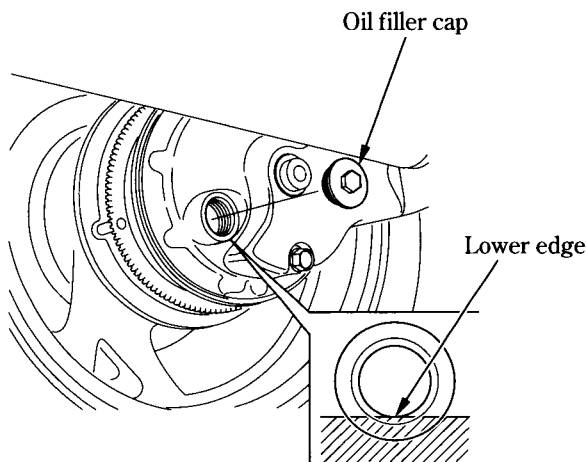

TUBELESS TYRES

To safely operate your motorcycle, your tyres must be the proper type and size, in good condition with adequate tread, and correctly inflated for the load you are carrying. The following pages give more detailed information on how and when to check your air pressure, how to inspect your tyres for damage, and what to do when your tyres need to be repaired or replaced.

WARNING

Using tyres that are excessively worn or improperly inflated can cause a crash in which you can be seriously hurt or killed.

Follow all instructions in this owner's manual regarding tyre inflation and maintenance.

Air Pressure

Keeping your tyres properly inflated provides the best combination of handling, tread life and riding comfort. Generally, underinflated tyres wear unevenly, adversely affect handling, and are more likely to fail from being overheated. Overinflated tyres make your motorcycle ride harshly, are more prone to damage from road hazards, and wear unevenly.

We recommend that you visually check your tyres before every ride and use a gauge to measure air pressure at least once a month or any time you think the tyres might be low.

Tubeless tyres have some self-sealing ability if they are punctured. However, because leakage is often very slow, you should look closely for punctures whenever a tyre is not fully inflated.

MAJOR COMPONENTS

(Information you need to operate this motorcycle)

Always check air pressure when your tyres are “cold” – when the motorcycle has been parked for at least three hours. If you check air pressure when your tyres are “warm” – when the motorcycle has been ridden for even a few miles – the readings will be higher than if the tyres were “cold”. This is normal, so do not let air out of the tyres to match the recommended cold air pressures given below. If you do, the tyres will be underinflated.

The recommended “cold” tyre pressures are:

Front	290 kPa (2.90 kgf/cm ² , 42 psi)
Rear	290 kPa (2.90 kgf/cm ² , 42 psi)

Inspection

Whenever you check the tyre pressures, you should also examine the tyre treads and sidewalls for wear, damage, and foreign objects:

Look for:

- Bumps or bulges in the side of the tyre or the tread. Replace the tyre if you find any bumps or bulges.
- Cuts, splits or cracks in the tyre. Replace the tyre if you can see fabric or cord.
- Excessive tread wear.

Also, if you hit a pothole or hard object, pull to the side of the road as soon as you can safely and carefully inspect the tyres for damage.

Tread Wear

Replace tyres before tread depth at the center of the tyre reaches the following limit:

Minimum tread depth	
Front	1.5 mm (0.06 in)
Rear	2.0 mm (0.08 in)

< For Germany >

German law prohibits use of tyres whose tread depth is less than 1.6 mm.

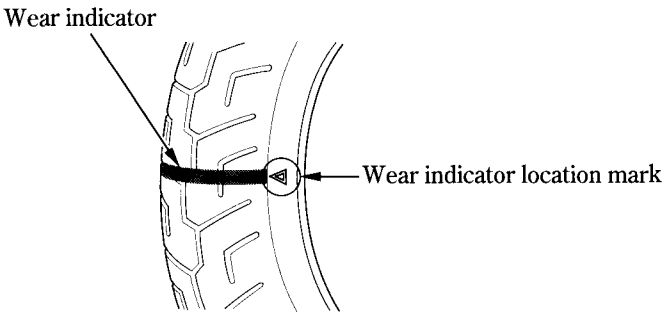

Tyre Repair

If a tyre is punctured or damaged, you should replace it, not repair it. As discussed below, a tyre that is repaired, either temporarily or permanently, will have lower speed and performance limits than a new tyre.

A temporary repair, such as an external tubeless tyre plug, may not be safe for normal speeds and riding conditions. If a temporary or emergency repair is made to a tyre, you should ride slowly and cautiously to a dealer and have the tyre replaced. If possible, you should not carry a passenger or cargo until a new tyre is installed.

Even if a tyre is professionally repaired with a permanent internal patch plug, it will not be as good as a new tyre. You should not exceed 80 km/h (50 mph) for the first 24 hours, or 130 km/h (80 mph) at any time thereafter. In addition, you may not be able to safely carry as much weight as with a new tyre. Therefore, we strongly recommend that you replace a damaged tyre. If you choose to have a tyre repaired, be sure the wheel is balanced before you ride.

MAJOR COMPONENTS

(Information you need to operate this motorcycle)

Tyre Replacement

The tyres that came on your motorcycle were designed to match the performance capabilities of your motorcycle and provide the best combination of handling, braking, durability and comfort.

WARNING

Installing improper tyres on your motorcycle can affect handling and stability. This can cause a crash in which you can be seriously hurt or killed.

Always use the size and type of tyres recommended in this owner's manual.

The recommended tyres for your motorcycle are:

Front	120/70ZR18M/C (59W)
	BRIDGESTONE BT020F F DUNLOP D220FST L
Rear	170/60ZR17M/C (72W)
	BRIDGESTONE BT020R F DUNLOP D220ST L
Type	radial-ply, tubeless

Whenever you replace a tyre, use one that is equivalent to the original and be sure the wheel is balanced after the new tyre is installed.

Important Safety Reminders

- Do not install a tube inside a tubeless tyre on this motorcycle. Excessive heat build-up can cause the tube to burst.
- Use only tubeless tyres on this motorcycle. The rims are designed for tubeless tyres, and during hard acceleration or braking, a tube-type tyre could slip on the rim and cause the tyre to rapidly deflate.
- Do not install a bias-ply tyre on this motorcycle. Mixing bias-ply and radial tyres can adversely affect handling and stability.
- Do not install car tyres on this motorcycle. During installation the tyre may separate from the rim with enough force to cause serious injury or death.
- When replacing tyres, use only the recommended tyres as shown above and on the tyre information label. Use of other tyres on the model equipped with ABS may impair proper ABS function.

The ABS computer works by comparing wheel speed.

Non-recommended tyres can affect wheel speed and may confuse the ABS computer.

ESSENTIAL INDIVIDUAL COMPONENTS

IGNITION SWITCH

The ignition switch is below the indicator panel.

The headlight, position light and taillights will come on whenever you turn the ignition switch ON. If your motorcycle is stopped with the ignition switch ON and the engine is not running, the headlight, position light and taillights will still be on, resulting in battery discharge.

Key Position	Function	Key Removal
LOCK (steering lock)	No electrical circuits function. Locks the steering head.	can be removed
OFF	No electrical circuits function.	can be removed
ON	Electrical circuits on.	cannot be removed
ACC	Only the accessory circuits function.	cannot be removed

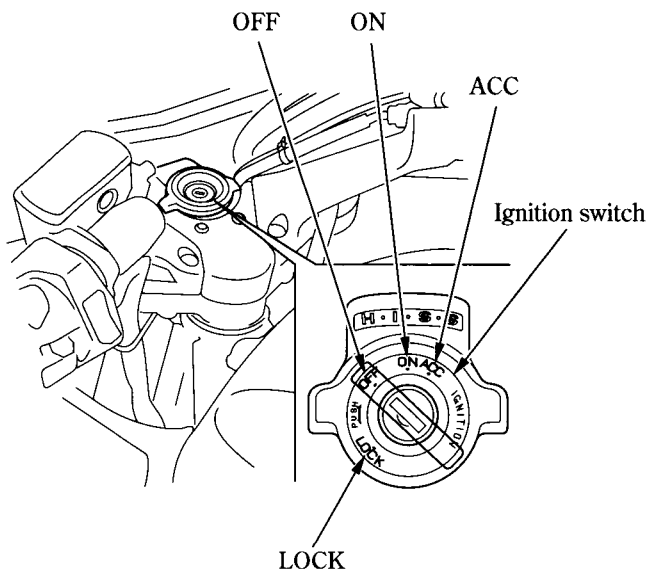

KEYS

This motorcycle has two keys and a key number plate.

< Except F type >

< For F type >

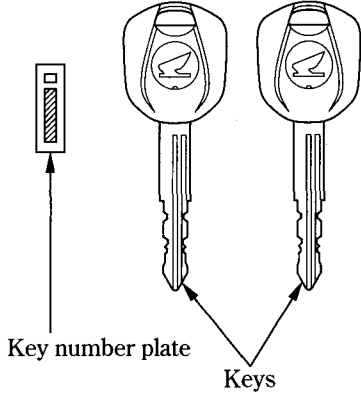
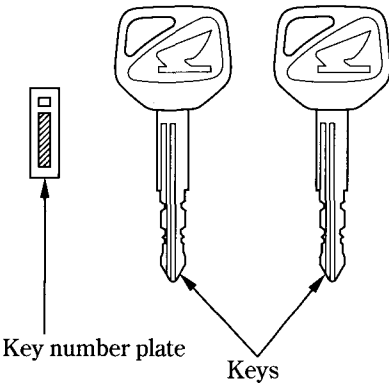

You will need the key number if you ever have to replace a key. Store the plate in a safe place.

To reproduce keys, bring all keys, key number plate and motorcycle to your Honda dealer.

Up to four keys can be registered with the immobilizer system (HISS), including the ones in hand.

If all keys are lost, the PGM-FI unit/ignition control module must be replaced. To avoid this possibility we recommend that if only one key is left, you immediately have it reproduced to ensure that a back-up is available.

These keys contain electronic circuits that are activated by the immobilizer system (HISS). They will not work to start the engine if the circuits are damaged.

- Do not drop the keys or set heavy objects on them.
- Do not grind, drill or in any way alter the original shape of the keys.
- Keep the keys away from magnetic objects.

ESSENTIAL INDIVIDUAL COMPONENTS

IMMOBILIZER SYSTEM (HISS)

HISS is the abbreviation of Honda Ignition Security System.

The immobilizer system (HISS) protects your motorcycle from theft. A properly-coded key must be used in the ignition switch for the engine to start. If an improperly-coded key (or other device) is used the engine's starting circuit is disabled.

When the ignition switch is turned ON and the engine stop switch is at " \bigcirc " (RUN), the immobilizer system (HISS) indicator lights for a few seconds, then goes off. If the indicator remains on, it means the system does not recognize the coding of the key. Turn the ignition switch to OFF, remove the key, reinsert and turn the switch ON again.

The immobilizer system has such a function that keeps the immobilizer system (HISS) indicator blinking at 2 second intervals for 24 hours. This blinking function can be turned on or off.

To alter the blinking function.

1. Turn the ignition switch ON.
2. Press and hold the CLOCK/ILLUM button for more than 2 seconds. The clock will be set in the adjust mode with the display flashing.
3. Turn the ignition switch OFF within 5 seconds.

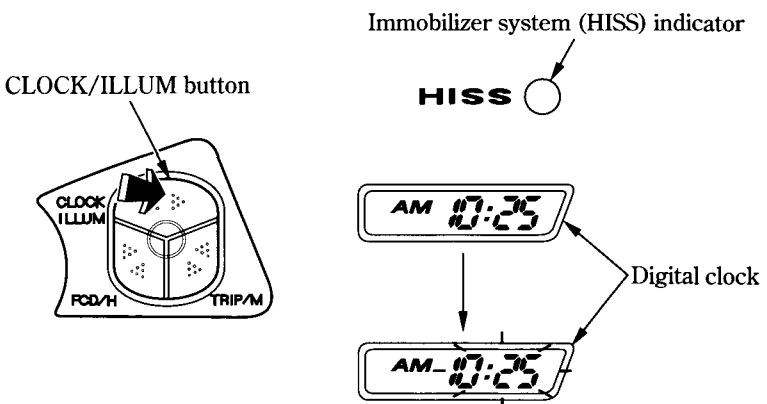

If the system repeatedly does not recognize the coding of your key, contact your Honda dealer.

- The system may not recognize the key's coding if any other immobilizer key is near the ignition switch. To make sure the system recognizes the key code, keep each immobilizer key on a separate ring.
- Do not attempt to alter the immobilizer system (HISS) or add other devices to it. Electrical problems could result, making it impossible to start your motorcycle.
- If all keys are lost, the PGM-FI unit/ignition control module must be replaced.

EC Directives

This immobilizer system complies with the R & TTE (Radio equipment and telecommunications terminal equipment and the mutual recognition of their conformity) Directive.





The declaration of conformity to R & TTE Directive is provided to the owner at the time of purchase. The declaration of conformity should be kept at a safe place. When the declaration of conformity is lost or is not provided, contact your Honda dealer.

ESSENTIAL INDIVIDUAL COMPONENTS

RIGHT HANDLEBAR CONTROLS

Engine Stop Switch

The engine stop switch is next to the throttle grip. When the switch is in the  (RUN) position, the engine will operate. When the switch is in the  (OFF) position, the engine will not operate. This switch is intended primarily as a safety or emergency switch and should normally remain in the  (RUN) position.

Start Button

The start button is below the engine stop switch.

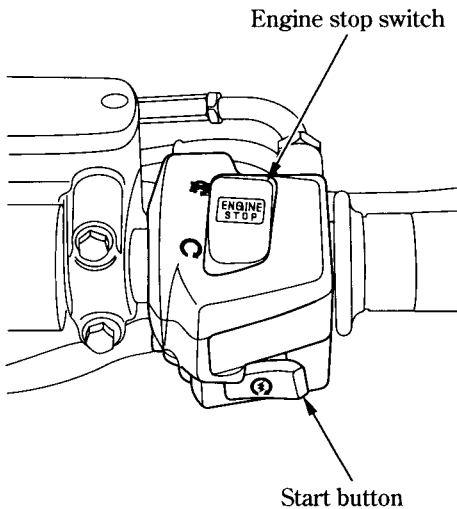

When the start button is pressed, the starter motor cranks the engine. If the engine stop switch is in the  (OFF) position, the starter motor will not operate. See page 71 for the starting procedure.



LEFT HANDLEBAR CONTROLS

The controls next to left handlebar grip are:

Headlight Dimmer Switch

Push the dimmer switch to  (HI) to select high beam or to  (LO) to select low beam.

Passing Light Control Switch

When this switch is pressed, the headlight flashes on to signal approaching cars or when passing.

Horn Button

Press the button to sound the horn.

Turn Signal Switch

Move to  to signal a left turn,  to signal a right turn. Press to turn signal off.

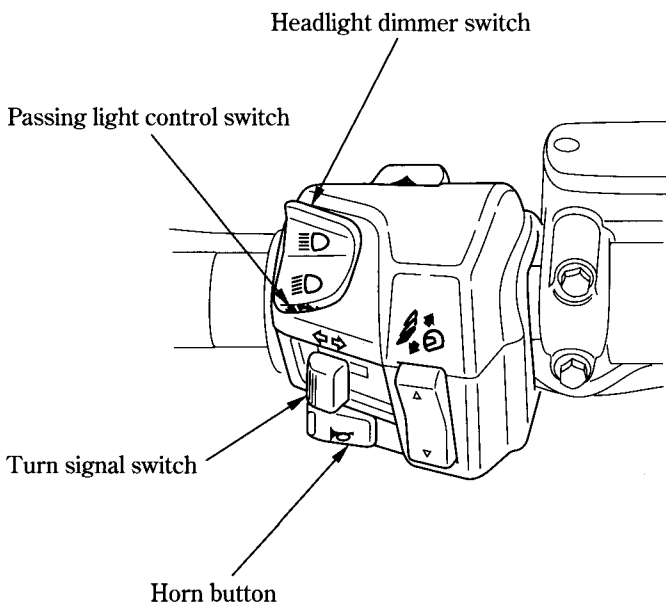

ESSENTIAL INDIVIDUAL COMPONENTS

WINDSCREEN HEIGHT ADJUSTMENT SWITCH

The maximum amount of height adjustment is about 190 mm (7.4 in). Adjust the height with the adjusting buttons according to your preference as described below.

To Adjust the Height of the Windscreen:

1. Turn the ignition switch ON.

To raise the windscreen:
push the ▲ (up) button.

To lower the windscreen:
push the ▼ (down) button.

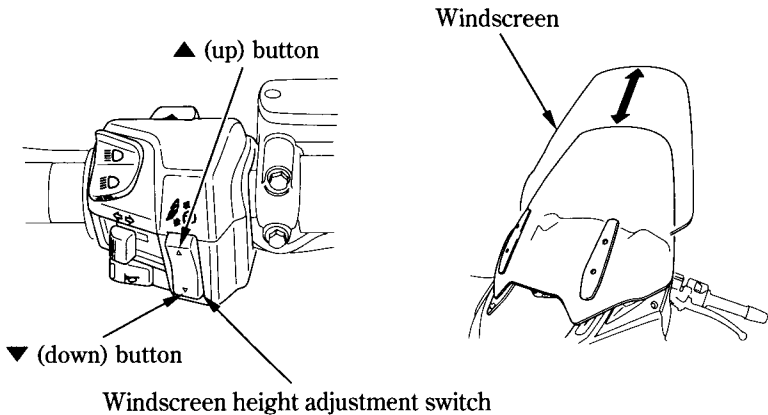

The windscreen will be raised or lowered while the adjusting buttons are kept depressed.

When you lower the windscreen, please check the new position will allow safe operation of the motorcycle.

HAZARD WARNING SYSTEM SWITCH

This system should be used only when your motorcycle is stopped under emergency or hazardous conditions. To turn it on, turn the ignition key to the ON or ACC position, and then push the switch marked . The front and rear turn signals will blink simultaneously.

Be sure to turn the switch off when the hazard warning is no longer required, or the turn signals will not work properly, and may confuse other drivers.

Hazard warning system switch

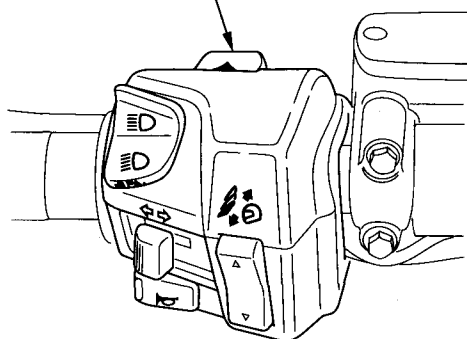

FEATURES

(Not required for operation)

STEERING LOCK

To lock the steering, turn the handlebars all the way to the left or right, turn the key to LOCK while pushing in. Remove the key.

To unlock the steering, turn the key to OFF while pushing in.

Do not turn the key to LOCK while riding the motorcycle; loss of vehicle control will result.

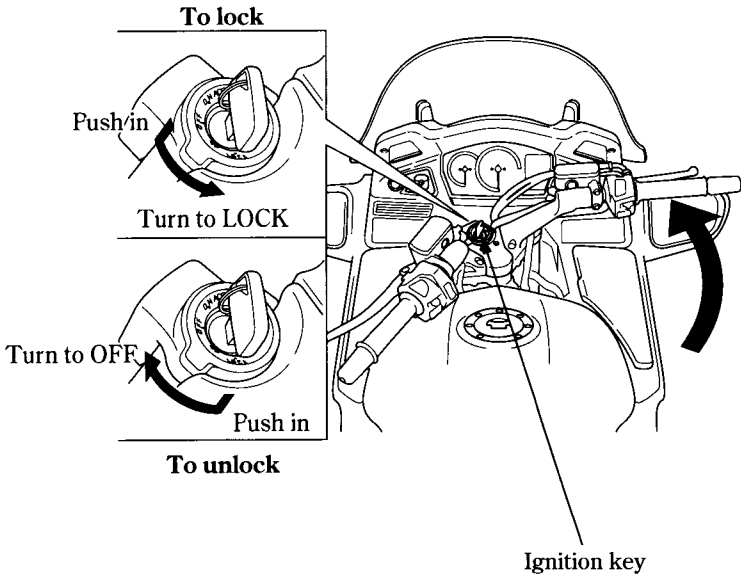

SEAT

To Remove the Rear Seat:

Insert the ignition key and turn it clockwise to open the left latch lever. Pull the rear seat back and up while depressing a seat opener.

To Remove the Front Seat:

Remove the front seat. Pull the front seat back and up.

To Install the Front Seat:

Insert the prongs A into the recesses. Insert the prong B into the seat height adjuster. Push down on the rear of the front seat.

Be sure to align the holes in the rear of the front seat with the adjuster when install the front seat.

To Install the Rear Seat:

Install the front seat. Insert the prongs into the recesses under the frame cross member and then push down on the rear of the rear seat. Close the latch lever and turn the ignition key counterclockwise.

Be sure the seat is locked securely in position after installation.

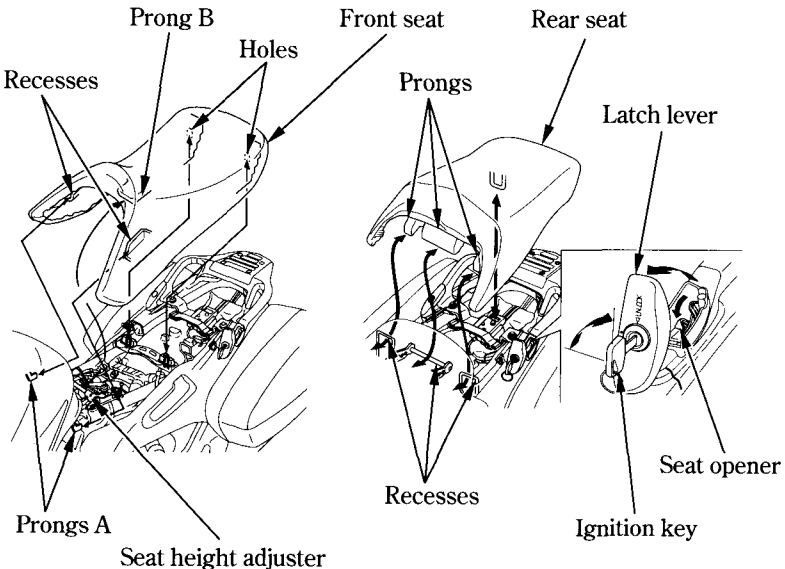

FEATURES

(Not required for operation)

The front seat can be adjusted to one of three positions in 15 mm (0.6 in) increments.

Adjust the height according to your preference as described below.

To Adjust the Height of the Front Seat:

1. Remove the front and rear seat (page 55).
2. Slide the seat height adjuster toward the rear, then set it in the guide.

Seat height adjuster

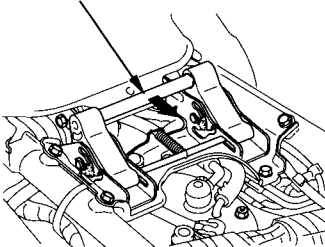

Guide

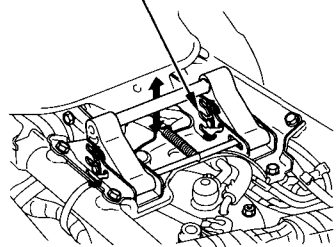

Be sure to align the hole in the rear of the front seat with the adjuster when install the front seat.

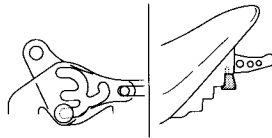

LOW position

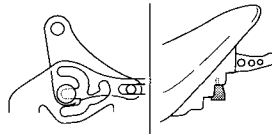

MID position

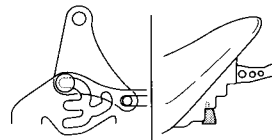

HIGH position

3. Install the front and rear seat (page 55).

HELMET HOLDERS

The helmet holders are located below the seat.

Remove the rear seat (page 55).

Hang the helmets on the holder hooks.

Install the rear seat and lock it securely.

⚠ WARNING

Riding with a helmet attached to the holder can interfere with the rear wheel or suspension and could cause a crash in which you can be seriously hurt or killed.

Use the helmet holder only while parked. Do not ride with a helmet secured by the holder.

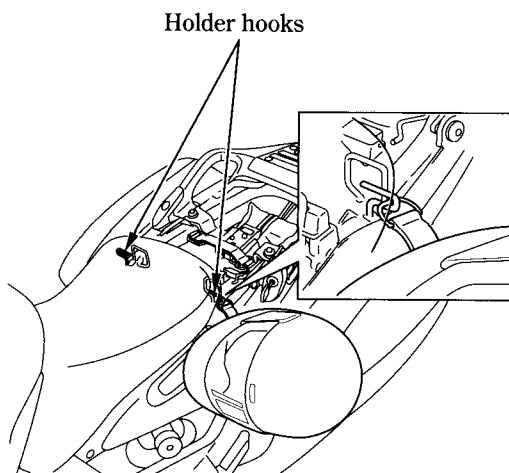

FEATURES

(Not required for operation)

SADDLEBAGS

The saddlebags are for lightweight items. Do not carry more than 9.0 kg (20.0 lbs) in each saddlebag.

To Open the Saddlebags:

Install the ignition key and turn it clockwise. Pull the handle up to open the saddlebags.

To Lock the Saddlebags:

Close the saddlebags and handle. Turn the ignition key counterclockwise. Make sure the saddlebags are locked.

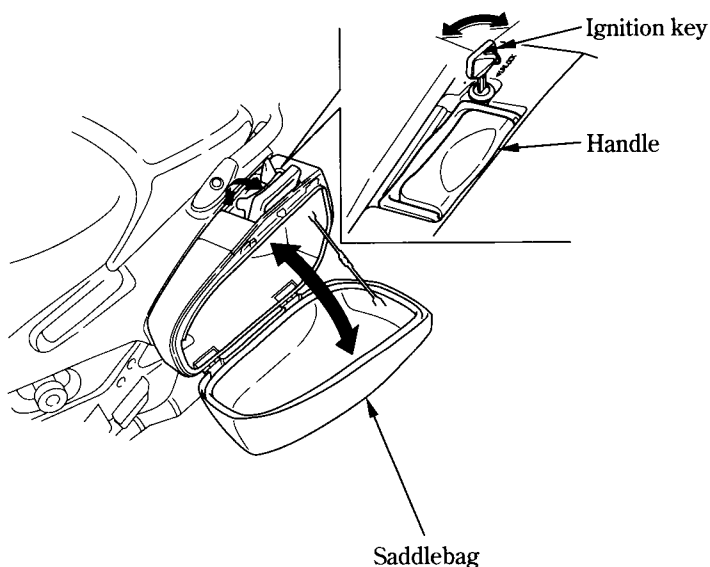

To Remove the Saddlebags:

Insert the ignition key and turn it clockwise to open the latch lever. Remove the saddlebag by lifting up and pulling it out toward you as shown. After removing, lock the latch lever with ignition key.

To Install the Saddlebags:

Installation can be done in the reverse order of removal.

After installing the saddlebag, check that the slot engages securely.

Close the latch lever and turn the ignition key counterclockwise.

Make sure the latch levers are locked before riding.

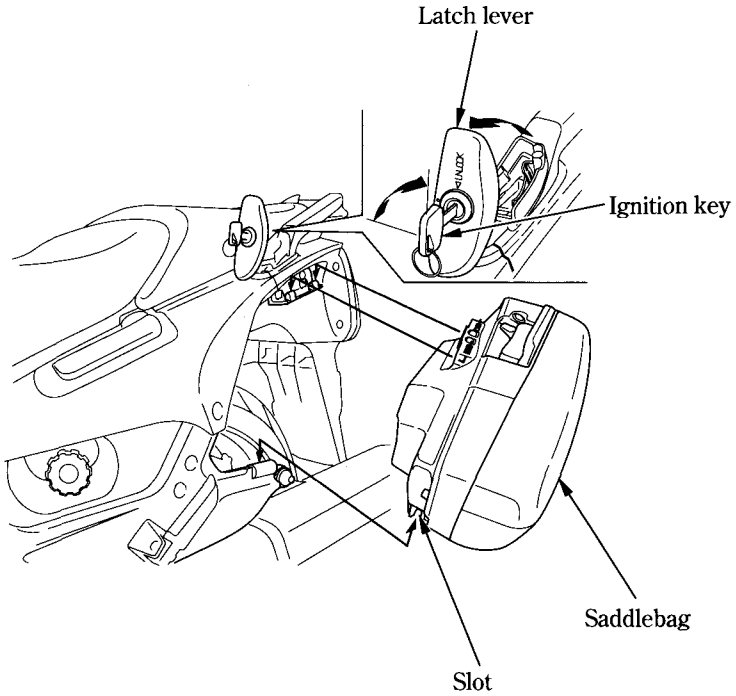

FEATURES

(Not required for operation)

FAIRING POCKETS

The fairing pockets are for lightweight items. Do not carry more than 2.0 kg (4.5 lbs) in each fairing pocket.

To open the left fairing pocket, insert the ignition key, turn it clockwise.

To open the right fairing pocket, pull the knob.

To shut each fairing pocket, place your hands flat on the edges of its lid and press down until it is firmly closed.

Do not open the each fairing pocket while riding the motorcycle.

Make sure the fairing pockets are closed before riding.

When washing your motorcycle, be careful not to flood this area with water.

Do not store valuables or fragile articles in the fairing pockets.

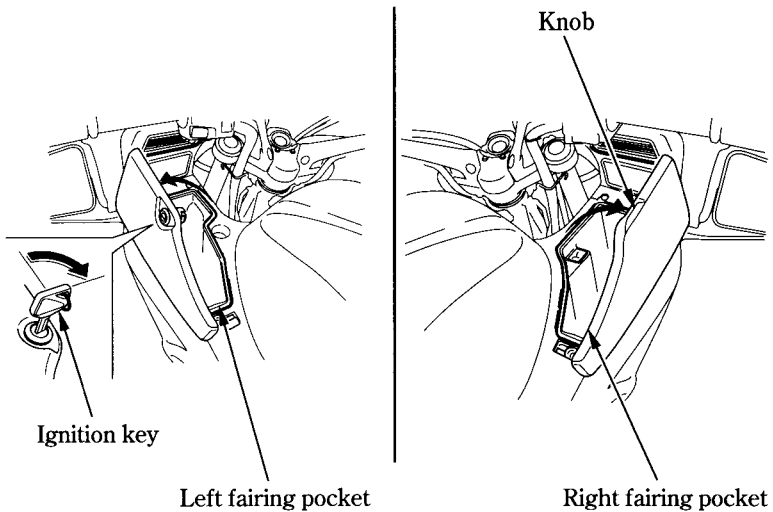

WINDSCREEN HEIGHT ADJUSTMENT

The height of the initial position may be adjusted 60 mm (2.3 in) to a higher or lower position.

To Adjust the Height of an Initial Configuration:

1. Raise the windscreen to the top position (page 52).
2. Remove the windscreen cover by removing the screws.

To raise:

Loosen the nuts and slide the windscreen to set lower guide.

To lower:

Loosen the nuts and slide the windscreen to set upper guide.

3. Tighten the nuts and install the windscreen cover after adjustment.
Make sure the windscreen is fixed before riding.

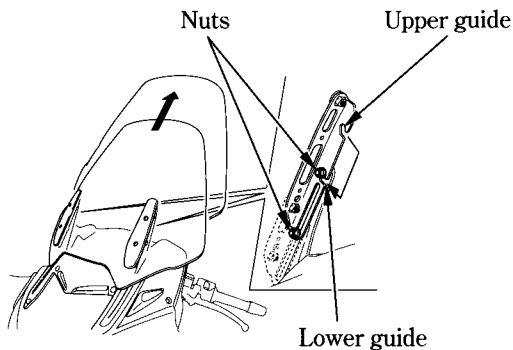
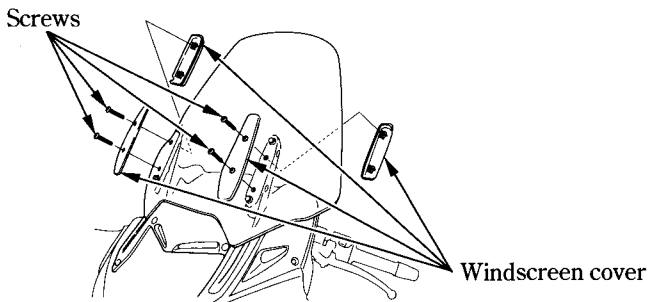

FEATURES

(Not required for operation)

DOCUMENTS

The owner's manual and other documents should be stored under the rear seat.

When washing your motorcycle, be careful not to flood this area with water.

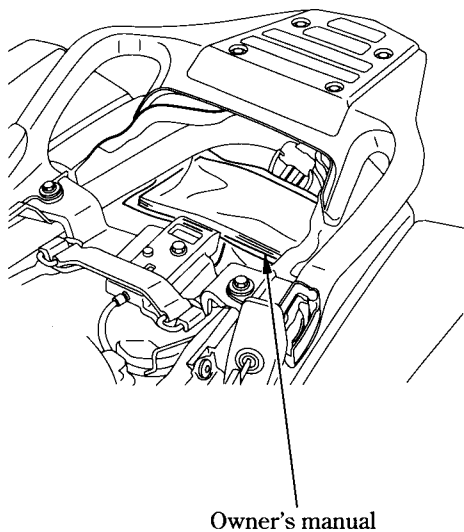

STORAGE COMPARTMENT FOR U-SHAPED ANTI-THEFT LOCK

The rear fender has a storage compartment to store a U-shaped anti-theft lock under the seat. After storing, be sure to fasten the lock with the rubber band securely.

Some U-shaped locks may not be stored in the compartment due to their size or design.

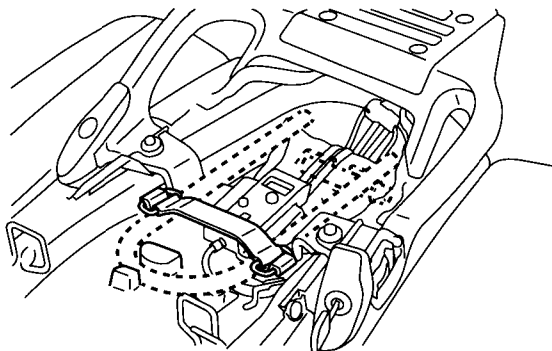

FEATURES

(Not required for operation)

REARVIEW MIRRORS

Both rear view mirror assemblies use a special breakaway mount which allows a controlled separation of the mirror assembly from its base upon impact with an obstacle. A short cable keeps the mirror assembly connected to the mirror bracket.

Inspection:

- Check the mirror for correct angle.
- Press on the mirror cover firmly until it clicks into position on the mirror mount.
- After reinstalling, check the mirror for correct angle and the front turn signals for proper operation.

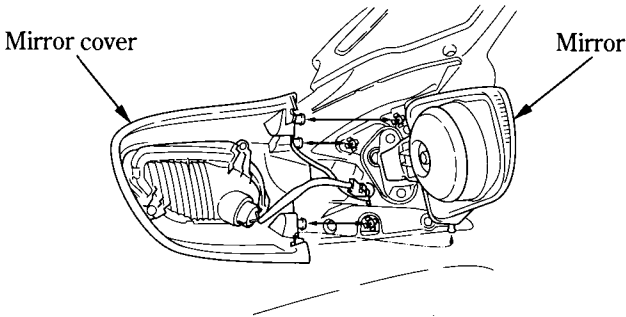

For your safety, be sure to immediately reinstall any separated mirror assembly. Otherwise, the mirror and turn signal will not be available to you while riding.

If a mirror assembly is damaged so badly that it cannot be reused or reinstalled on its base, remove it from the base and transport the motorcycle to Honda dealer.

NOTICE

Riding with a mirror assembly hanging by its retaining cable may damage the motorcycle's plastic body.

HEADLIGHT AIM VERTICAL ADJUSTMENT

Vertical adjustment can be made by turning the headlight beam adjustment knob as necessary.

Obey local laws and regulations.

To Operate:

Turn the ignition switch to ON.

To lower the beam, turn headlight beam adjustment knob counterclockwise.

To raise the beam, turn the knob clockwise.

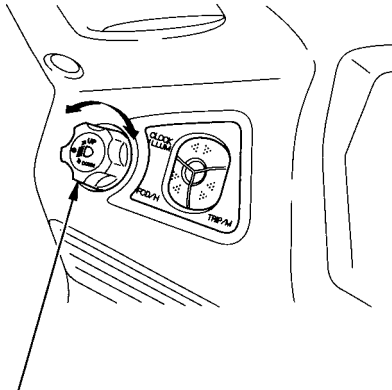

Headlight beam adjustment knob

FEATURES

(Not required for operation)

CLIP

Removal:

1. Press down on the center pin to release the lock.
2. Pull out the clip from the hole.

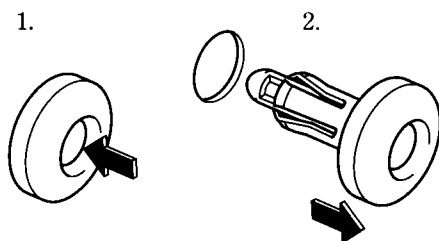

Installation:

1. Push the bottom of the pin.
2. Insert the clip into the hole.
3. Lightly press down on the center pin to lock the clip.

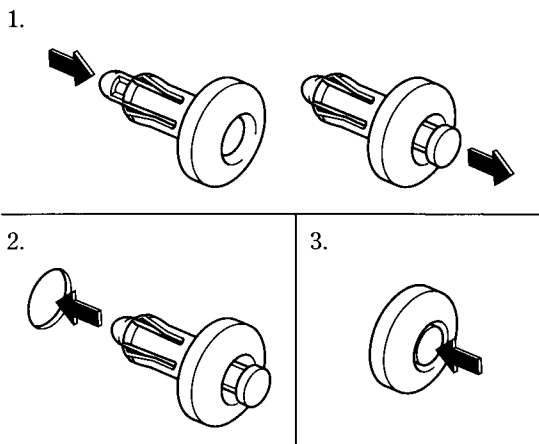

FUEL TANK MAINTENANCE POSITION

The front of the fuel tank can be tilted up for maintenance.
The fuel tank does not require draining.

To Raise:

1. Place the motorcycle on its center stand on a firm, level surface with the transmission in neutral and the ignition switch OFF. Check that the fuel fill cap is closed.
2. Remove the front and rear seat (page 55).
3. Remove the fuel tank bolts and steering stem cap.
4. The seat adjuster is set in the maintenance position after sliding it to the rear of the motorcycle.
5. Loosen the nut while holding the pivot bolt at the other end with a wrench.
6. Slide the fuel tank to the rear of the motorcycle.

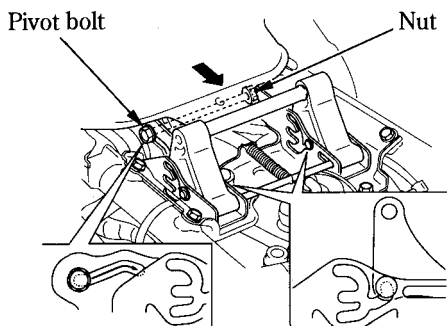
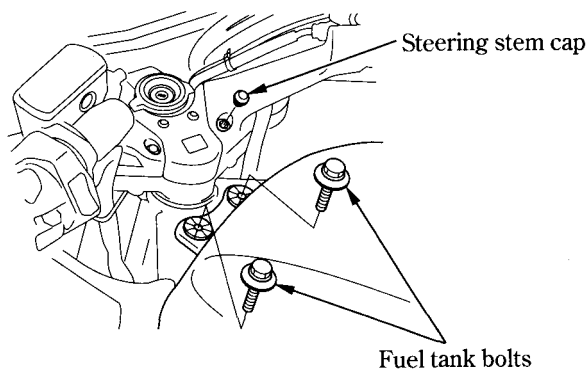

FEATURES

(Not required for operation)

7. Remove the tank open rod from under the seat.
8. Raise the front of the fuel tank and place the tank open rod between the front of the fuel tank and steering stem.

Do not raise the fuel tank higher than the stopper cable allows.

9. Tighten the nut while holding the pivot bolt at the other end with a wrench.

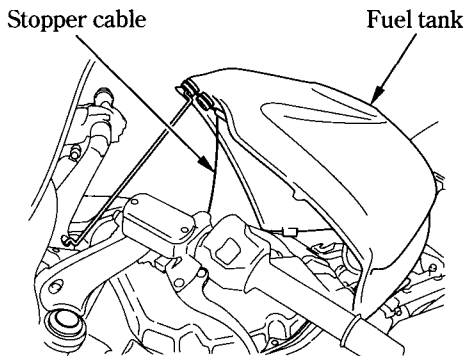
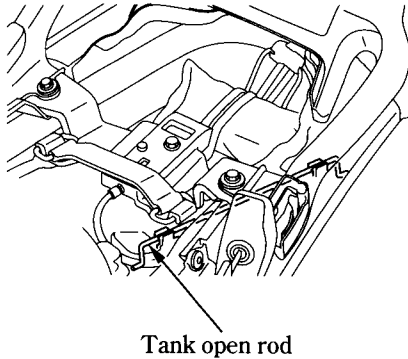

OPERATION

PRE-RIDE INSPECTION

For your safety, it is very important to take a few moments before each ride to walk around your motorcycle and check its condition. If you detect any problem, be sure you take care of it, or have it corrected by your Honda dealer.

⚠ WARNING

Improperly maintaining this motorcycle or failing to correct a problem before riding can cause a crash in which you can be seriously hurt or killed.

Always perform a pre-ride inspection before every ride and correct any problems.

1. Engine oil level—add engine oil if required (page 39). Check for leaks.
2. Fuel level—fill fuel tank when necessary (page 36). Check for leaks.
3. Coolant level—add coolant if required. Check for leaks (pages 34 – 35).
4. Front and rear brakes—check operation; make sure there is no brake fluid leakage (pages 30 – 32).
5. Tyres – check condition (pages 41 – 45) and pressure (page 41).
6. Throttle—check for smooth opening and full closing in all steering positions.
7. Lights and horn—check that headlight, brake/tail light, turn signals, indicators and horn function properly.
8. Engine stop switch—check for proper function (page 50).
9. Side stand ignition cut-off system—check for proper function (page 104).

OPERATION

STARTING THE ENGINE

Always follow the proper starting procedure described below.

This motorcycle is equipped with a side stand ignition cut-off system. The engine cannot be started if the side stand is down, unless the transmission is in neutral. If the side stand is up, the engine can be started in neutral or in gear with the clutch lever pulled in. After starting with the side stand down, the engine will shut off if the transmission is put in gear before raising the side stand.

To protect the catalytic converters in your motorcycle's exhaust system, avoid extending idling and the use of leaded petrol.

Your motorcycle's exhaust contains poisonous carbon monoxide gas. High levels of carbon monoxide can collect rapidly in enclosed areas such as a garage. Do not run the engine with the garage door closed. Even with the door open, run the engine only long enough to move your motorcycle out of the garage.

Do not use the electric starter for more than 5 seconds at a time. Release the start button for approximately 10 seconds before pressing it again.

Preparation

Before starting, insert the key, turn the ignition switch ON and confirm the following:

- The transmission is in neutral (neutral indicator light ON).
- The engine stop switch is at  (RUN).
- The low oil pressure indicator is ON.
- The PGM-FI malfunction indicator lamp (MIL) is OFF.
- The immobilizer system (HISS) indicator is OFF.
- The ABS indicator light is ON. (ST1300A)

The malfunction indicator lamp and low oil pressure indicator should go off a few seconds after the engine starts. If the malfunction indicator lamp and the low oil pressure indicator light during operation, stop the engine immediately and check the engine oil level.

NOTICE

Operating the engine with insufficient oil pressure can cause serious engine damage.

Starting Procedure

This motorcycle has a fuel-injected engine with an automatic fast idle. Follow the procedure indicated below.

Any Air Temperature:

- Press the start button with the throttle completely closed.

The engine will not start if the throttle is fully open (because the electronic control module cuts off the fuel supply).

Snapping the throttle or fast idling for more than about 5 minutes at normal air temperature may cause exhaust pipe discoloration.

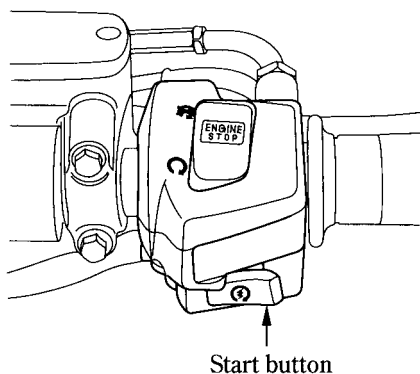

Flooded Engine

If the engine fails to start after repeated attempts, it may be flooded with excess fuel. To clear a flooded engine.

1. Leave the engine stop switch set to  (RUN).
2. Open throttle fully.
3. Press the start button for 5 seconds.
4. Follow the normal starting procedure.
5. If the engine starts with unstable idle, open the throttle slightly.

If the engine does not start, wait for 10 seconds, then follow steps 1–4 again.

Ignition Cut Off

Your motorcycle is designed to automatically stop the engine and fuel pump if the motorcycle is over-turned (a banking sensor cuts off the ignition system). Before restarting the engine, you must turn the ignition switch to the OFF position and then back to ON.

OPERATION

RUNNING-IN

Help assure your motorcycle's future reliability and performance by paying extra attention to how you ride during the first 500 km (300 miles).

During this period, avoid full-throttle starts and rapid acceleration.

RIDING

Review Motorcycle Safety (pages 1 – 10) before you ride.

Make sure you understand the function of the side stand mechanism. (See MAINTENANCE SCHEDULE on page 83 and explanation for SIDE STAND on page 104).

Make sure flammable materials such as dry grass or leaves do not come in contact with the exhaust system when riding, idling, or parking your motorcycle.

1. After the engine has been warmed up, the motorcycle is ready for riding.
2. While the engine is idling, pull in the clutch lever and depress the shift lever to shift into 1st (low) gear.
3. Slowly release the clutch lever and at the same time gradually increase engine speed by opening the throttle. Coordination of the throttle and clutch lever will assure a smooth positive start.
4. When the motorcycle attains a moderate speed, close the throttle, pull in the clutch lever and shift to 2nd gear by raising the shift lever.
This sequence is repeated to progressively shift to 3rd, 4th and 5th (top) gears.
5. Coordinate the throttle and brakes for smooth deceleration.
6. Both front and rear brakes should be used at the same time and should not be applied strongly enough to lock the wheel, or braking effectiveness will be reduced and control of the motorcycle be difficult.

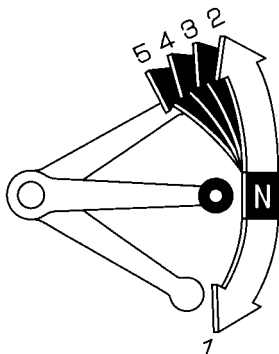

OPERATION

BRAKING

This motorcycle is equipped with a Dual Combined Brake System. Operating the front brake lever applies the front brake and a portion of the rear brake. Operating the rear brake pedal applies the rear brake and a portion of the front brake. For full braking effectiveness, use both the lever and pedal simultaneously, as you would with a conventional motorcycle braking system.

As with a conventional motorcycle braking system, excessively hard application of the brake controls may cause wheel lock, reducing control of the motorcycle.

For normal braking, apply both the brake pedal and lever while down-shifting to match your road speed. For maximum braking, close the throttle and firmly apply the pedal and lever; pull in the clutch lever before coming to a complete stop to prevent stalling the engine.

Important Safety Reminders:

- When possible, reduce speed or brake before entering a turn; closing the throttle or braking in mid-turn may cause wheel slip. Wheel slip will reduce control of the motorcycle.
- When riding in wet or rainy conditions, or on loose surfaces, the ability to maneuver and stop will be reduced. All of your actions should be smooth under these conditions. Rapid acceleration, braking or turning may cause loss of control. For your safety, exercise extreme caution when braking, accelerating or turning.
- When descending a long, steep grade, use engine compression braking by downshifting, with intermittent use of both brakes.
Continuous brake application can overheat the brakes and reduce their effectiveness.
- Riding with your foot resting on the brake pedal or your hand on the brake lever may actuate the brakelight, giving a false indication to other drivers. It may also overheat the brakes, reducing effectiveness.

Anti-lock Brake System (ABS) (ST1300A)

This model is also equipped with an Anti-lock Brake System (ABS) designed to help prevent wheel lock up during hard braking on uneven or other poor surfaces while running straight. Although the wheel may not lock up—if you are braking too hard in a turn the motorcycle can still lose traction, causing a loss of control.

In some situations, a motorcycle with ABS may require a longer stopping distance to stop on loose or uneven surfaces than an equivalent motorcycle without ABS.

ABS cannot make up for road conditions, bad judgment, or improper operation of the brakes. It is still your responsibility to ride at reasonable speeds for weather, road surface, and traffic conditions, and to leave a margin of safety.

ABS is self-checking and always on.

- ABS may be activated by riding over a sharp drop or rise in the road level. It is important to follow the tyre recommendations (page 44). The ABS computer works by comparing wheel speed. Non-recommended tyres can affect wheel speed and may confuse the ABS computer.
- ABS does not function at low speeds (approximately 10 km/h (6 mph) or below).
- ABS does not function if the battery is discharged.

OPERATION

ABS Indicator Light (ST1300A)

Normally, this light comes on when the ignition is turned ON, and goes off after you ride the motorcycle at speed above 10 km/h (6 mph). If there is an ABS problem, the indicator light flashes and remains on. The ABS system does not operate when the ABS indicator light is on.

If the ABS indicator light comes on while riding, stop the motorcycle in a safe place and turn off the engine.

Turn the ignition ON again. The light should come on, and go off after you ride the motorcycle at speeds above 10 km/h (6 mph). If it does not go off, ABS is not functioning, but the brakes still work a Dual Combined Brake System and provide normal stopping ability. However, you should have the system checked by Honda dealer as soon as possible.

The ABS indicator light may flash if you turn the rear wheel while the motorcycle is upright on the stand. This is normal. Turn the ignition OFF, then turn it ON. The indicator should come on, then go off after you run the motorcycle above 10 km/h (6 mph).

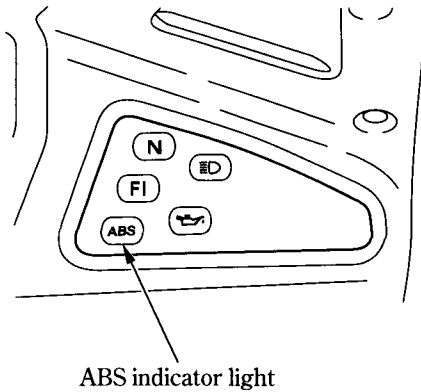

PARKING

1. After stopping the motorcycle, shift the transmission into neutral, turn the ignition switch OFF and remove the key.
2. Use the side or center stand to support the motorcycle while parked.

Park the motorcycle on firm, level ground to prevent it from falling over. If you must park on a slight incline, aim the front of the motorcycle uphill to reduce the possibility of overturning or rolling off the center or side stand.

3. Lock the steering to help prevent theft (page 54).

Make sure flammable materials such as dry grass or leaves do not come in contact with the exhaust system when parking your motorcycle.

OPERATION

ANTI-THEFT TIPS

1. Always lock the steering and never leave the key in the ignition switch. This sounds simple but people do forget.
2. Be sure the registration information for your motorcycle is accurate and current.
3. Park your motorcycle in a locked garage whenever possible.
4. Use an additional anti-theft device of good quality.
5. Put your name, address, and phone number in this Owner's Manual and keep it on your motorcycles at all times.

Many times stolen motorcycles are identified by information in the Owner's Manuals that are still with them.

NAME: _____

ADDRESS: _____

PHONE NO: _____

MAINTENANCE

THE IMPORTANCE OF MAINTENANCE

A well-maintained motorcycle is essential for safe, economical and trouble-free riding. It will also help reduce air pollution.

To help you properly care for your motorcycle, the following pages include a Maintenance Schedule and a Maintenance Record for regularly scheduled maintenance.

These instructions are based on the assumption that the motorcycle will be used exclusively for its designed purpose. Sustained high speed operation or operation in unusually wet or dusty conditions will require more frequent service than specified in the Maintenance Schedule. Consult your Honda dealer for recommendations applicable to your individual needs and use.

If your motorcycle overturns or becomes involved in a crash, be sure your Honda dealer inspects all major parts, even if you are able to make some repairs.

WARNING

Improperly maintaining this motorcycle or failing to correct a problem before you ride can cause a crash in which you can be seriously hurt or killed.

Always follow the inspection and maintenance recommendations and schedules in this owner's manual.

MAINTENANCE

MAINTENANCE SAFETY

This section includes instructions on some important maintenance tasks. You can perform some of these tasks with the tools provided – if you have basic mechanical skills.

Other tasks that are more difficult and require special tools are best performed by professionals. Wheel removal should normally be handled only by a Honda technician or other qualified mechanic; instructions are included in this manual only to assist in emergency service.

Some of the most important safety precautions follow. However, we cannot warn you of every conceivable hazard that can arise in performing maintenance. Only you can decide whether or not you should perform a given task.

WARNING

Failure to properly follow maintenance instructions and precautions can cause you to be seriously hurt or killed.

Always follow the procedures and precautions in this owner's manual.

SAFETY PRECAUTIONS

- Make sure the engine is off before you begin any maintenance or repairs. This will help eliminate several potential hazards:
 - * **Carbon monoxide poisoning from engine exhaust.**
Be sure there is adequate ventilation whenever you operate the engine.
 - * **Burns from hot parts.**
Let the engine and exhaust system cool before touching.
 - * **Injury from moving parts.**
Do not run the engine unless instructed to do so.
- Read the instructions before you begin, and make sure you have the tools and skills required.
- To help prevent the motorcycle from falling over, park it on a firm, level surface, using the center stand or a maintenance stand to provide support.
- To reduce the possibility of a fire or explosion, be careful when working around petrol or batteries. Use only nonflammable solvent, not petrol, to clean parts. Keep cigarettes, sparks and flames away from the battery and all fuel-related parts.

Remember that your Honda dealer knows your motorcycle best and is fully equipped to maintain and repair it.

To ensure the best quality and reliability, use only new Honda Genuine Parts or their equivalents for repair and replacement.

MAINTENANCE

MAINTENANCE SCHEDULE

Perform the Pre-ride Inspection (page 69) at each scheduled maintenance period.

I: INSPECT AND CLEAN, ADJUST, LUBRICATE OR REPLACE IF NECESSARY

C: CLEAN R: REPLACE A: ADJUST L: LUBRICATE

The following Maintenance Schedule specifies all maintenance required to keep your motorcycle in peak operating condition. Maintenance work should be performed in accordance with standards and specifications of Honda by properly trained and equipped technicians. Your Honda dealer meets all of these requirements.

- * Should be serviced by your Honda dealer, unless the owner has proper tools and service data and is mechanically qualified. Refer to the Official Honda Shop Manual.
- ** In the interest of safety, we recommend these items be serviced only by your Honda dealer.

Honda recommends that your Honda dealer should road test your motorcycle after each periodic maintenance is carried out.

NOTES:

1. At higher odometer readings, repeat at the frequency interval established here.
2. Service more frequently if the motorcycle is ridden in unusually wet or dusty areas.
3. Replace every 2 years, or at indicated odometer interval, whichever comes first. Replacement requires mechanical skill.