

**2005
Honda TRX250TM
FOURTRAX RECON
OWNER'S MANUAL**

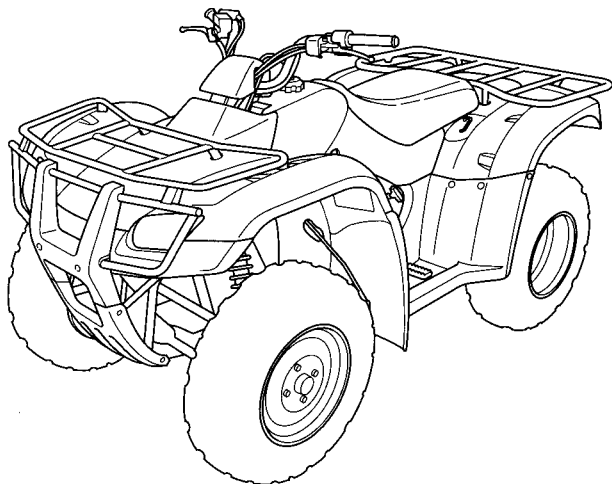

FOR OFF-ROAD USE ONLY

This vehicle is designed and manufactured for off-road use only.
USA only:

It conforms to US EPA Noise Emission regulations, but does not conform to Federal Motor Vehicle Safety Standards or US EPA On Highway Exhaust Emission regulations, and operation on public streets, roads, or highways is illegal. The vehicle is equipped with a USDA qualified spark arrester. Obey local laws and regulations.

It conforms to US EPA and California exhaust emission regulations for ATVs.

Introduction

Congratulations on choosing your Honda ATV.

When you own a Honda, you're part of a worldwide family of satisfied customers — people who appreciate Honda's reputation for building quality into every product.

Your Honda was designed as a recreational ATV for off-road use by one rider only.

Before riding, take time to get acquainted with your ATV and how it works. To protect your investment, we urge you to take responsibility for keeping your ATV well maintained. Scheduled service is a must, of course. But it's just as important to observe the break-in guidelines, and perform all pre-ride and other periodic checks detailed in this manual.

We also recommend that you read this owner's manual before you ride. It's full of facts, instructions, safety information, and helpful tips. To make it easy to use, the manual contains a detailed list of topics at the beginning of each section, and both an in-depth table of contents and an index at the back of the book.

As you read this manual, you will find information that is preceded by a **NOTICE** symbol. This information is intended to help you avoid damage to your Honda, other property, or the environment.

Read the Warranties Booklet (page 191) thoroughly so you understand the coverages that protect your new Honda and are aware of your rights and responsibilities.

Whenever you ride, tread lightly. By staying on established trails and riding only in approved areas, you help protect the environment and keep off-road riding areas open for the future.

Introduction

If you have any questions, or if you ever need special service or repairs, remember that your Honda dealer knows your ATV best and is dedicated to your complete satisfaction.

Please report any change of address or ownership to your Honda dealer so we will be able to contact you concerning important production information.

You may also want to visit our website at www.honda.com.

Happy riding!

California Proposition 65 Warning

WARNING: This product contains or emits chemicals known to the State of California to cause cancer and birth defects or other reproductive harm.

A Few Words About Safety

Your safety, and the safety of others, is very important. And operating this ATV safely is an important responsibility.

To help you make informed decisions about safety, we have provided operating procedures and other information on labels and in this manual. This information alerts you to potential hazards that could hurt you or others.

Of course, it is not practical or possible to warn you about all hazards associated with operating or maintaining an ATV. You must use your own good judgment.

You will find important safety information in a variety of forms, including:

Safety Labels — on the ATV.

Safety Messages — preceded by a safety alert symbol  and one of three signal words: **DANGER**, **WARNING**, or **CAUTION**.

A Few Words About Safety

These signal words mean:

▲ DANGER

You **WILL** be **KILLED** or **SERIOUSLY HURT** if you don't follow instructions.

▲ WARNING

You **CAN** be **KILLED** or **SERIOUSLY HURT** if you don't follow instructions.

▲ CAUTION

You **CAN** be **HURT** if you don't follow instructions.

Safety Headings — such as Important Safety Reminders or Important Safety Precautions.

Safety Section — such as ATV Safety.

Instructions — how to use this ATV correctly and safely.

This entire manual is filled with important safety information — please read it carefully.

Contents

These pages give an overview of the contents of your owner's manual. The first page of each section lists the topics covered in that section.

ATV Safety	1
Important safety information you should know, plus a look at the safety-related labels on your ATV.	
Indicators & Controls	9
The location and function of indicators and controls on your ATV and operating instructions for various controls and features.	
Before Riding.....	27
The importance of wearing a helmet and other protective gear, how to make sure you and your ATV are ready to ride, and important information about loading.	
Basic Operation & Riding	41
How to start and stop the engine, shift gears, and brake. Also, riding precautions.	

Contents

Servicing Your Honda	73
Why your ATV needs regular maintenance, what you need to know before servicing your Honda, an owner maintenance schedule, and instructions for specific maintenance and adjustment items.	
Tips	147
How to store and transport your ATV and how to be an environmentally-responsible rider.	
Taking Care of the Unexpected	157
What to do if you have a flat tire, your engine won't start, etc.	
Technical Information	171
ID numbers, technical specifications, and other technical facts.	
Consumer Information	187
Information on warranties, emission controls, how to get Honda service manuals.	
Table of Contents	196
Sequential listing of topics in this owner's manual.	
Index	202
Quick Reference	
Handy facts about fuel, engine oil, tire sizes, and air pressures.	

ATV Safety

This section presents some of the most important information and recommendations to help you ride your ATV safely. Please take a few moments to read these pages. This section also includes information about the location of safety labels on your ATV.

Important Safety Information	2
Safety Labels.....	5

Important Safety Information

Your ATV can provide many years of service and pleasure — if you take responsibility for your own safety and understand the challenges you can meet while riding.

There is much that you can do to protect yourself when you ride. You'll find many helpful recommendations throughout this manual. The following are a few that we consider most important.

Follow the Age Recommendation

The minimum recommended age for this ATV model is 16. Children under age 16 should never operate this vehicle.

Always Wear a Helmet

It's a proven fact: helmets significantly reduce the number and severity of head injuries. So always wear an approved motorcycle helmet. We also recommend that you wear eye protection, sturdy boots, gloves, and other protective gear (page 28).

Never Carry a Passenger

Your ATV is designed for one person only. There are no handholds, footrests, or seat for a second person — so never carry a passenger. A passenger could interfere with your ability to move around to maintain your balance and control of the ATV.

Important Safety Information

Ride Off-Road Only

Your ATV is designed and manufactured for off-road use only. The tires are not made for pavement, and the ATV does not have turn signals and other features required for use on public roads. If you need to cross a paved or public road, get off and walk your ATV across.

Take Time to Learn & Practice

Even if you have ridden other ATVs, take time to become familiar with how this ATV works and handles. Practice in a safe area until you build your skills and get accustomed to the ATV's size and weight.

Because many accidents involve inexperienced or untrained riders, we urge all riders to take a training course approved by the ATV Safety Institute (ASI). See page 30.

Contact an authorized ATV dealer or call 1-800-887-2887 (USA only) to find out about the training courses nearest you.

Be Alert for Off-Road Hazards

The terrain can present a variety of challenges when you ride off-road. Continually “read” the terrain for unexpected turns, drop-offs, rocks, ruts, and other hazards. Always keep your speed low enough to allow time to see and react to hazards.

Important Safety Information

Ride within Your Limits

Pushing limits is another major cause of ATV accidents. Never ride beyond your personal abilities or faster than conditions warrant. Remember that alcohol, drugs, fatigue, and inattention can significantly reduce your ability to make good judgments and ride safely.

Don't Drink and Ride

Alcohol and riding don't mix. Even one drink can reduce your ability to respond to changing conditions, and your reaction time gets worse with every additional drink. So don't drink and ride, and don't let your friends drink and ride either.

Keep Your Honda in Safe Condition

It's important to keep your ATV properly maintained and in safe riding condition. Having a breakdown can be difficult, especially if you are stranded off-road far from your base. To help avoid problems, inspect your ATV before every ride and perform all recommended maintenance.

Safety Labels

Your ATV comes with a hang tag and several labels containing important safety information. Anyone who rides the vehicle should read and understand this information before riding.

The labels should be considered permanent parts of the vehicle. If a label comes off or becomes hard to read, contact your Honda dealer for replacements.

Safety Labels

USA only

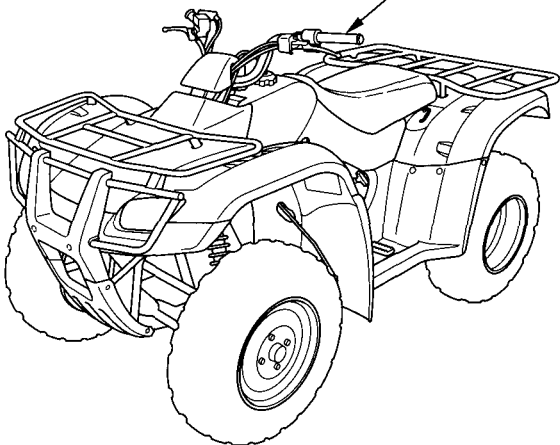
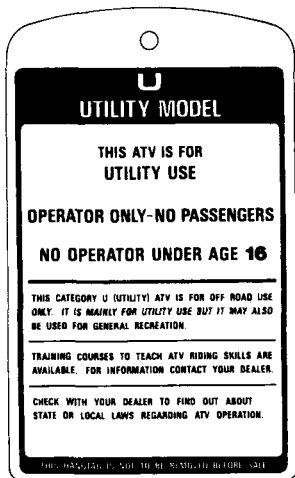
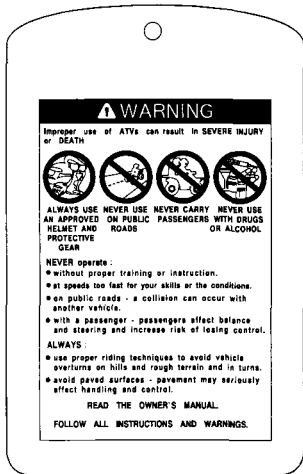

Safety Labels

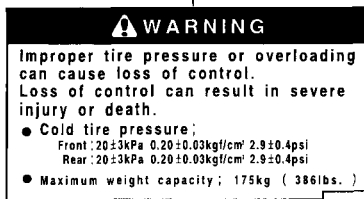
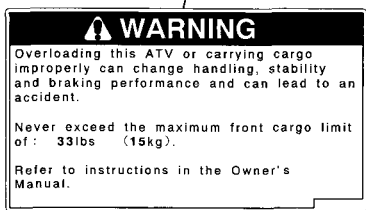
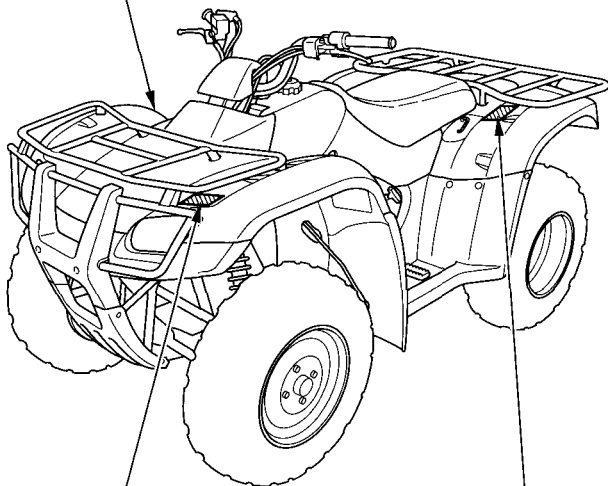
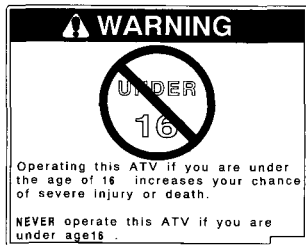

Safety Labels

WARNING



NEVER ride as a passenger. Passengers can cause a loss of control, resulting in **SEVERE INJURY** or **DEATH**.

WARNING

Overloading this ATV or carrying cargo improperly can change handling, stability and braking performance and can lead to an accident.

Never exceed the maximum rear cargo limit (combined weight on the rear rack and in the storage area) of: **66 lbs (30kg)**.

Refer to instructions in the Owner's Manual.

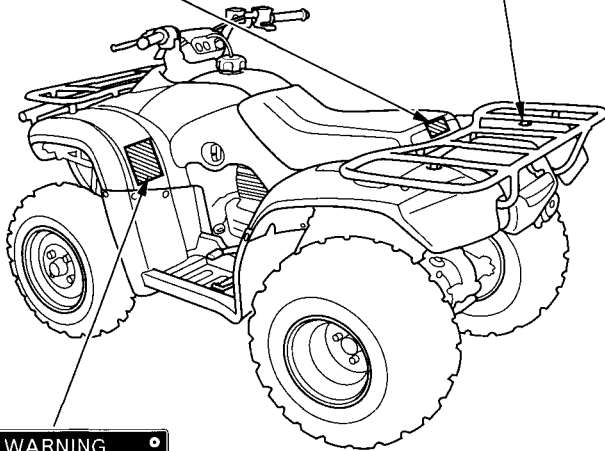

WARNING

Improper use of ATVs can result in **SEVERE INJURY** or **DEATH**



ALWAYS USE AN APPROVED HELMET AND PROTECTIVE GEAR **NEVER USE ON PUBLIC ROADS** **NEVER CARRY PASSENGERS** **NEVER USE WITH DRUGS OR ALCOHOL**

NEVER operate:

- without proper training or instruction.
- at speeds too fast for your skills or the conditions.
- on public roads - a collision can occur with another vehicle.
- with a passenger - passengers affect balance and steering and increase risk of losing control.

ALWAYS:

- use proper riding techniques to avoid vehicle overturns on hills and rough terrain and in turns.
- avoid paved surfaces - pavement may seriously affect handling and control.

READ THE OWNER'S MANUAL.

FOLLOW ALL INSTRUCTIONS AND WARNINGS.

Indicators & Controls

This section shows the location of all indicators and controls you would normally use before or while riding your ATV.

The items listed on this page are described in this section. Instructions for other components are presented in other sections of this manual where they will be most useful.

Component Locations	11
Indicators.....	14
Reverse and Neutral Indicators	14

(cont'd)

Indicators & Controls

Control and Features	15
Fuel Valve	15
Choke Knob	16
Ignition Switch.....	17
Start Button	18
Engine Stop Switch.....	18
Headlight Switch.....	19
Headlight Dimmer Switch.....	19
Recoil Starter.....	20
Throttle Lever	21
Reverse Selector Knob.....	22
Front Brake Lever	23
Rear Brake Lever	23
Rear Brake Pedal.....	23
Parking Brake.....	24
Flag Pole Bracket	25

Component Locations

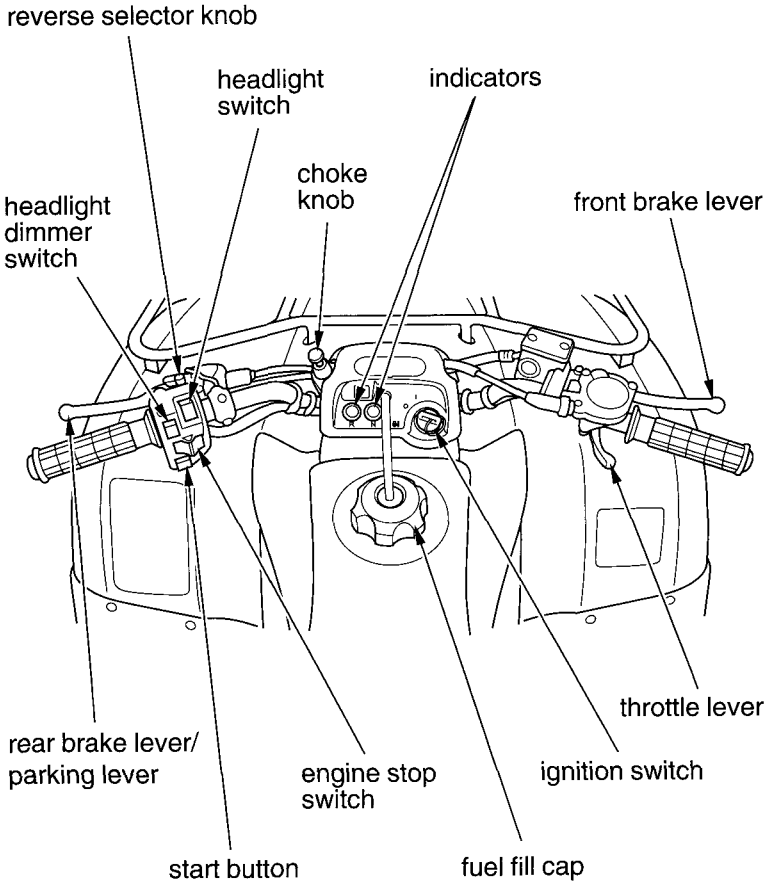

Component Locations

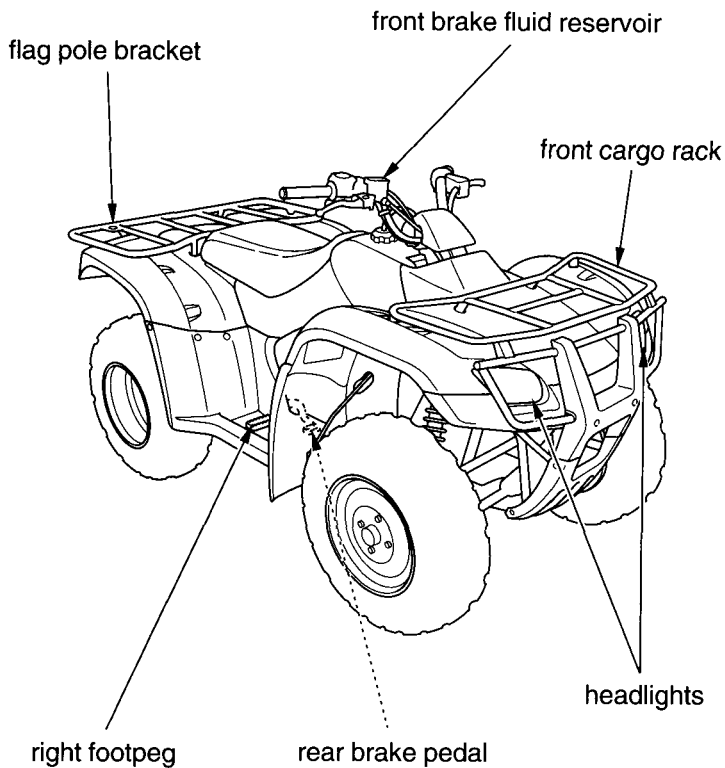

Component Locations

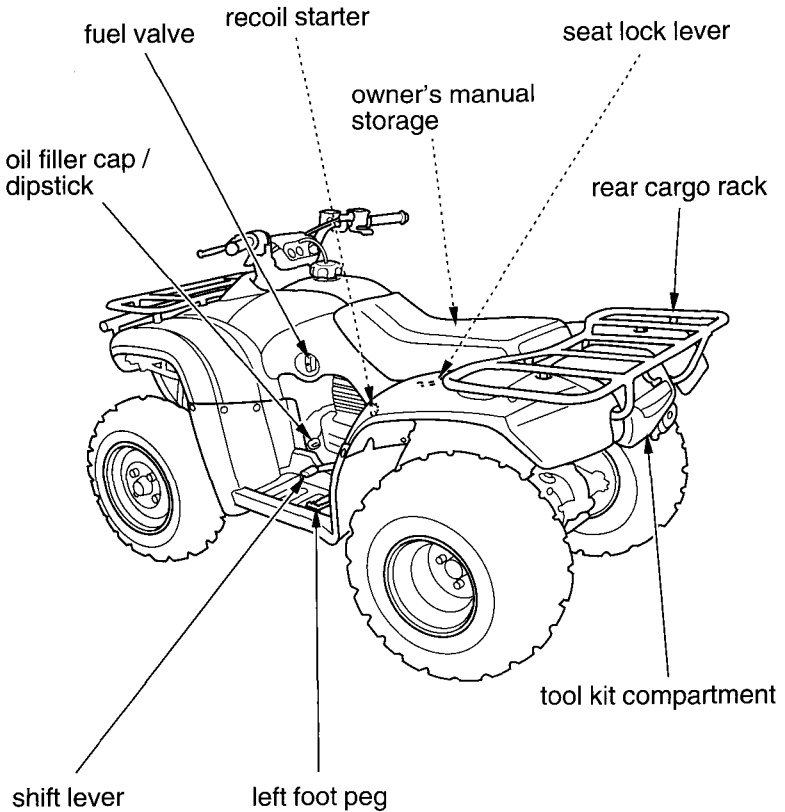

Indicators

Reverse and Neutral Indicators

The reverse indicator (1) and the neutral indicator (2) are next to the ignition switch.

The reverse indicator will light when the transmission is in reverse and the ignition switch is ON (I).

The neutral indicator will light when the transmission is in neutral and the ignition switch is ON (I).

If one of these indicators does not come on when it should, have your Honda dealer check for burned-out bulbs or other problems.

CENTER OF HANDLEBAR

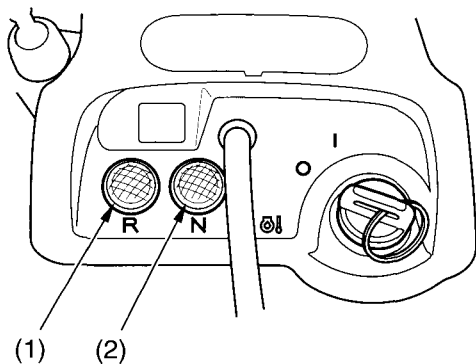

- (1) reverse indicator
- (2) neutral indicator

Controls & Features

Fuel Valve

LEFT SIDE

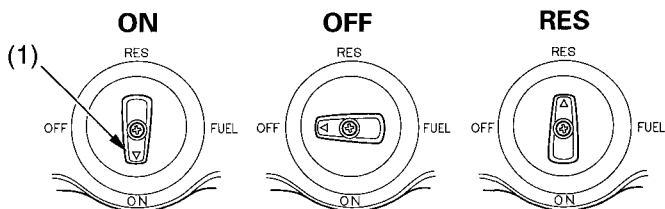

(1) fuel valve

The manual fuel valve is located on the left side of the fuel tank.

The three-way fuel valve is used to control the flow of fuel from the fuel tank to the carburetor.

ON—normal position for riding.

OFF— for parking, storing, or transportation.

RES— for extra fuel to get to a gas supply for refueling.

Reserve Fuel

Remember to check that the fuel valve is in the ON position each time you refuel. If the fuel valve is left in the RES position, you may run out of fuel with no reserve.

For complete information about fueling your ATV, see page 89 .

Controls & Features

Choke Knob

N

LEFT HANDLEBAR

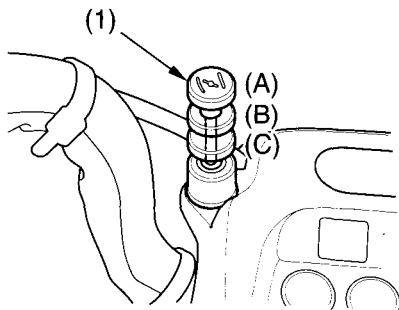

(1) choke knob

(A) fully ON

(B) half way position

(C) fully OFF

The choke knob (1) may be used when starting the engine. See page 48 .

Controls & Features

Ignition Switch

The ignition switch is used for starting and stopping the engine (page 48). Insert the key and turn it to the right for the ON (|) position.

Key Position	Function
ON ()	Electrical circuits on.
OFF (O)	No electrical circuits function.

CENTER OF HANDLEBAR

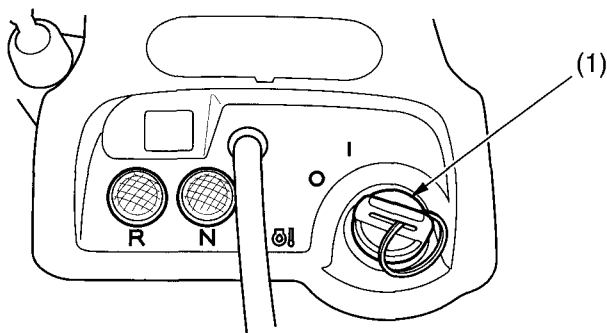

(1) ignition switch

| ON
O OFF

Controls & Features

Start Button



LEFT HANDLEBAR

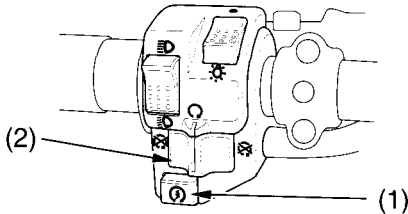

(1) start button

(2) engine stop switch

 START

 OFF



 RUN



The start button (1) is used for starting the engine. Pushing the button in starts the engine. See *Starting Procedure*, page 49.

When the start button is pushed, the starter motor will crank the engine. The starter motor will not operate if the engine stop switch is in the OFF () position when the start button is pushed.

Engine Stop Switch



The engine stop switch (2) is used to stop the engine in an emergency. To operate, press the switch to either OFF () position. The switch must be in the RUN () position to start the engine, and it should normally remain in the RUN () position even when the engine is OFF.

If your ATV is stopped with the ignition switch ON () and the engine stop switch OFF (), the battery will discharge. Turn the ignition switch OFF () to prevent battery discharge.

Controls & Features

Headlight Switch





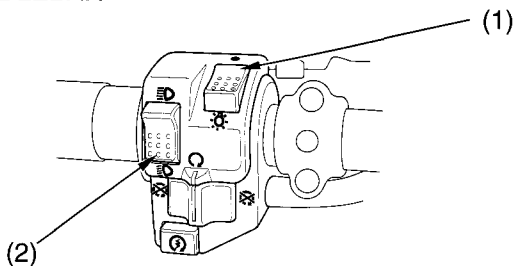





LEFT HANDLEBAR



(1) headlight switch



(2) headlight dimmer switch

-  ON
-  OFF
-  HI
-  LOW

The headlight switch (1) is used to turn the headlight ON () or OFF (). To operate, turn the switch to ON () or OFF ().

Headlight Dimmer Switch



The headlight dimmer switch (2) is used to change between the high and low beams of the headlight. To operate, turn the switch to HI () for high beam, LO () for low beam.

Controls & Features

Recoil Starter

LEFT SIDE

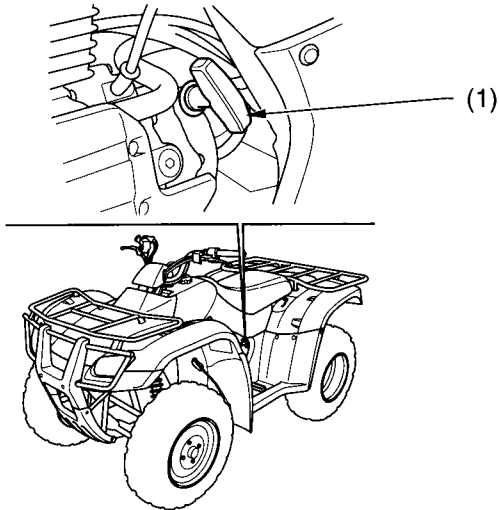

(1) recoil starter

The recoil starter (1) is used to start the engine when the battery is low.
See *Using the Recoil Starter*, page 53 .

Controls & Features

Throttle Lever

RIGHT HANDLEBAR

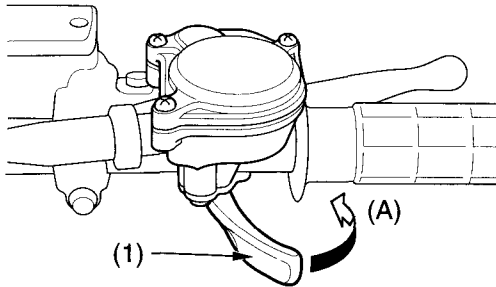

- (1) throttle lever
- (A) to open the throttle

The throttle controls engine rpm (speed). To increase engine rpm, press the lever (1) with your thumb. To reduce engine rpm, release pressure on the lever. The throttle will automatically return to the closed position (engine idle) when you remove your thumb.

Controls & Features

Reverse Selector Knob

The reverse selector knob (1), located on the rear brake lever (2), is used to shift into reverse. To operate, with your ATV stopped and the transmission in neutral (make sure the neutral indicator lights), push in the knob, squeeze the rear brake lever, then depress the shift lever. See *Riding in Reverse*, page 56 .

LEFT HANDLEBAR

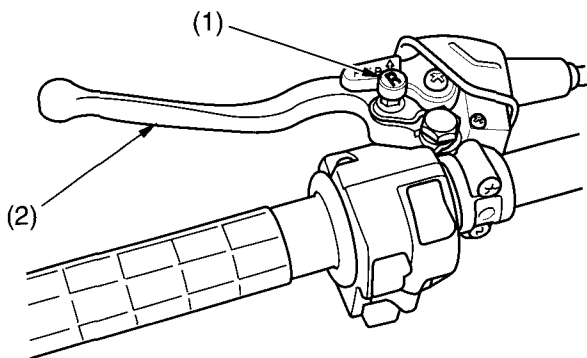

(1) reverse selector knob

(2) rear brake lever

Controls & Features

Front Brake Lever

The front brake lever is used to slow or stop your ATV. To operate, pull the lever. For information on braking techniques, see page 58 .

Rear Brake Lever

The rear brake lever is used to slow or stop your ATV. To operate, pull the lever. For information on braking techniques, see page 58 .

Rear Brake Pedal

The rear brake pedal is used to slow or stop your ATV. To operate, depress the pedal. For information on braking techniques, see page 58 .

Controls & Features

Parking Brake

LEFT HANDLEBAR

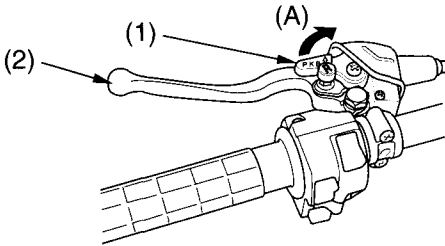

(1) lock lever

(A) to lock

(2) rear brake lever/parking lever

The lock lever (1) on the rear brake lever (2) allows it to be used as a parking brake. To operate, first squeeze the rear brake lever using your left hand and then lock it with the lock lever using your right hand. See *Parking* page 72 .

The brakelights are activated by applying the parking brake. When using the parking brake, be sure to turn the ignition switch OFF (○) to avoid discharging the battery.

Controls & Features

Flag Pole Bracket

RIGHT REAR

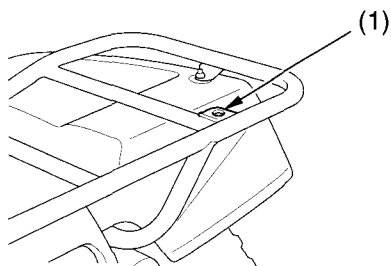

(1) flag pole bracket

Flag poles are optional equipment available from your Honda dealer. To mount a pole in the bracket (1), follow the instructions that come with the flag pole kit.

Flag poles are required in some riding areas. Check local regulations before riding.

Before Riding

Before each ride, you need to make sure you and your Honda are both ready to ride. To help get you prepared, this section discusses how to evaluate your riding readiness, what items you should check on your ATV, and adjustments to make for your comfort, convenience, or safety. This section also includes important information about loading.

Are You Ready to Ride ?	28
Protective Apparel.....	28
Rider Training	30
Age Recommendation	31
No Passengers	31
No Alcohol or Drugs.....	32
Is Your ATV Ready to Ride ?.....	33
Pre-ride Inspection	33
Load Limits & Guideline	36
Loading	36
Load Limits	37
Loading Guidelines	38
Accessories & Modifications	39
Accessories.....	39
Modifications	40

Are You Ready to Ride?

Before you ride your ATV for the first time, we urge you to:

- Read this owner's manual and the labels on your ATV carefully.
- Make sure you understand all the safety messages.
- Know how to operate all the controls.

Before each ride, be sure:

- You feel well and are in good physical and mental condition.
- You are wearing an approved motorcycle helmet (with chin strap tightened securely), eye protection, and other protective clothing.
- You don't have any alcohol or drugs in your system.

Protective Apparel

For your safety, we strongly recommend that you always wear an approved motorcycle helmet, eye protection, boots, gloves, long pants, and a long-sleeved shirt or jacket whenever you ride.

Although complete protection is not possible, wearing proper gear can reduce the chance of injury when you ride.

Following are suggestions to help you choose the proper gear.

Helmets and Eye Protection

Your helmet is your most important piece of riding gear because it offers the best protection against head injuries. A helmet should fit your head comfortably and securely.

Are You Ready to Ride?

An open-face helmet offers some protection, but a full-face helmet offers more. Regardless of the style, look for a DOT (Department of Transportation) sticker in any helmet you buy (USA only). Always wear a face shield or goggles to protect your eyes and help your vision.

⚠ WARNING

Operating this ATV without wearing an approved motorcycle helmet, eye protection, and protective clothing could increase your chances of severe injury or death in the event of an accident.

Always wear an approved motorcycle helmet that fits properly and wear eye protection (goggles or face shield), gloves, boots, long-sleeved shirt or jacket and long pants.

Additional Riding Gear

In addition to a helmet and eye protection, we also recommend:

- Sturdy off-road motorcycle boots to help protect your feet, ankles, and lower legs.
- Off-road motorcycle gloves to help protect your hands.
- Riding pants with knee and hip pads, a riding jersey with padded elbows, and a chest/shoulder protector.

Are You Ready to Ride?

Rider Training

Developing your riding skills is an on-going process. Even if you have ridden other ATVs, take time to become familiar with how this ATV works and handles. Practice riding the ATV in a safe area to build your skills. Do not ride in rough terrain until you get accustomed to the ATV's controls, and feel comfortable with its size and weight.

We urge all riders to take a certified course approved by the ATV Safety Institute (ASI). For information about the ASI training course nearest you, call the national toll-free number; (800) 887-2887 (USA only).

Other riding tips can be found in the *Tips & Practice Guide for the ATV Rider* booklet that came with your ATV (USA only).

⚠ WARNING

Operating this ATV without proper instruction could increase your risk of an accident which could lead to serious injury or death.

Beginning and inexperienced operators should complete the certified training course offered by Honda. They should then regularly practice the skills learned in the course and the operating techniques described in the owner's manual.

Are You Ready to Ride?

Age Recommendation

The minimum recommended age for this ATV model is 16. For safety, never let children under 16 years old operate this vehicle.

WARNING

A child using an ATV that is not recommended for their age could lose vehicle control while riding, resulting in severe injury or death.

A child under 16 should never operate an ATV with engine size greater than 90cc.

No Passengers

This ATV is designed as an operator-only vehicle. The long seat is designed to allow the rider to change body position, not for carrying a passenger. Never let a passenger ride on the seat or on the front or rear cargo racks.

WARNING

Carrying a passenger on this ATV greatly reduces your ability to balance and control this ATV and could cause a crash and you or your passenger could be injured or killed.

Never carry a passenger on this ATV.

Are You Ready to Ride?

No Alcohol or Drugs

Alcohol, drugs and ATVs don't mix. Even a small amount of alcohol can impair your ability to operate an ATV safely. Likewise, drugs – even if prescribed by a physician – can be dangerous while operating an ATV. Consult your doctor to be sure it is safe to operate a vehicle after taking medication.

WARNING

Operating this ATV after consuming alcohol or drugs can seriously affect your judgement, cause you to react more slowly, affect your balance and perception, and result in serious injury or death.

Never consume alcohol or drugs before or while operating this ATV.

Is Your ATV Ready to Ride?

Before each ride, it's important to inspect your ATV and make sure any problem you find is corrected. A pre-ride inspection is a must, not only for safety, but because having a breakdown, or even a flat tire, can be a major inconvenience.

If your ATV has overturned or been involved in a collision, do not ride the vehicle until it has been inspected by your Honda dealer. There may be damage or other problems you cannot see.

WARNING

Improperly maintaining this ATV or failing to correct a problem before riding can cause a crash in which you can be seriously hurt or killed.

Always perform a pre-ride inspection before every ride and correct any problems.

Pre-ride Inspection

Check the following items before you get on the ATV:

Engine Oil

Check the level and add oil if needed (page 92).
Check for leaks.

Fuel

Check the level and add fuel (page 89) if needed. Also make sure the fuel fill cap is securely fastened.
Check for leaks.

Is Your ATV Ready to Ride?

<i>Tires</i>	Use a gauge to check the air pressure. Adjust if needed. Also look for signs of damage or excessive wear (page 133).
<i>Nuts & Bolts</i>	Check the wheels to see that the axle nuts are tightened. Use a wrench to make sure all accessible nuts, bolts, and fasteners are tight.
<i>Underbody & Exhaust System</i>	Check for, and remove, any dirt, vegetation or other debris that could be a fire hazard or interfere with the proper operation of the vehicle.
<i>Air Cleaner Housing Drain Tube</i>	Check for deposits in the drain tube. If necessary, clean the tube (page 104) and check the air cleaner housing.
<i>Leaks, Loose Parts</i>	Walk around your ATV and look for anything that appears unusual, such as a leak or loose cable.
<i>Cable</i>	Check the cable housings for wear. Check the fittings for looseness. Replace or tighten as needed.
<i>Lights</i>	Make sure the headlight, brakelight and tail light are working properly.

Is Your ATV Ready to Ride?

If you are carrying cargo, also check the following:

Loading Limits Make sure you do not exceed the load limits (page 37).

Cargo Check that all cargo is secure.

Check these items after you get on the ATV:

Throttle Check the freeplay and adjust if needed. Press the throttle to make sure it moves smoothly without sticking, and snaps shut automatically when it is released, in all steering positions (page 105).

Brakes Squeeze the front and rear brake levers and step on the rear brake pedal to check that the controls operate normally. Check for proper freeplay (pages 119, 123, 125). Make sure there is no brake fluid leakage.

*Headlight and
Headlight Dimmer
Switch* Check for proper function (page 19).

*Engine Stop
Switch* Check for proper function (page 18).

Steering Check that the wheels turn properly as you steer the handlebar.

Remember, be sure to take care of any problem you find, or have your Honda dealer correct it before you ride.

Load Limits & Guidelines

Your Honda was designed as a rider-only ATV. It was not designed to carry a passenger. It can carry cargo on the cargo racks, however, carrying cargo anywhere else or carrying a passenger could interfere with your balance and control of the ATV.

In addition, exceeding the weight limits or carrying an unbalanced load can seriously affect your ATV's handling, braking and stability. Adding accessories or making modifications that change this ATV's design and performance can also make it unsafe. Also, the weight of any accessories will reduce the maximum load the ATV can carry.

More specific information on load limits, accessories, and modifications follows.

Loading

How much weight you put on your ATV, and how you load it, are important to your safety. If you decide to carry cargo, you should be aware of the following information.

⚠ WARNING

Overloading, improper loading, or carrying a passenger can cause a crash and you can be seriously hurt or killed.

Follow all load limits and other loading guidelines in this manual.

Load Limits & Guidelines

Load Limits

Following are the load limits for your ATV:

There are limits to how much weight can be carried on your ATV and be pulled in a trailer.

The following load limits apply to standard equipment only. Modifying your ATV, using non-standard equipment, or riding on terrain that is not flat and smooth could further reduce these limits.

maximum weight capacity 386 lbs (175 kg)
(includes the weight of the rider, all cargo, and accessories.)

front cargo rack weight limit = 33 lbs (15 kg)

rear cargo rack weight limit = 66 lbs (30 kg)

tow weight limit = 500 lbs {225 kgf}

(Combined weight of the trailer
and all cargo in the trailer) (2206 N)

tongue weight = 30 lbs {14 kgf}

(Weight on the trailer tongue) (137 N) recommended

tongue and rear cargo weight = 66 lbs (30 kg)

(Combined weight on the trailer
tongue, on the rear cargo rack,
and in the storage area)

Tongue weight can be measured with an ordinary bathroom scale. Place the scale under the tongue, using either a tongue jack or other support to keep the trailer level.

The weight of added accessories will reduce the maximum cargo weight you can carry.

Load Limits & Guidelines

Loading Guidelines

Carrying cargo or pulling a trailer will affect how your ATV handles and greatly reduce its ability in accelerating, braking and making turns and other maneuvers.

Be sure to observe the weight limits and follow these guidelines:

- Check that the tires are properly inflated.
- Do not place cargo anywhere on the ATV other than on the front and rear racks. Otherwise, operating stability may be adversely affected.
- Never ride with a passenger on the front or rear cargo racks. The ATV is not designed to carry a passenger.
- Load cargo on the rear rack as far forward as possible. Make sure cargo on the front rack does not interfere with handlebar movement.
- Do not allow cargo to extend beyond the edges of either the front or rear racks.
- Make sure all cargo is secured before riding.
- Balance cargo weight evenly on both sides.
- Never exceed the maximum weight limit.
- When towing a trailer, take care to maintain balance and stability. Distribute cargo between the front and rear of the trailer to obtain the recommended tongue weight.
- Allow extra room for starting, stopping and turning whenever you carry cargo or pull a trailer.
- Avoid riding on steep slopes when carrying cargo or pulling a trailer.
- Never cross a slope when towing a trailer.

Accessories & Modifications

Modifying your ATV or using non-Honda accessories can make your ATV unsafe.

Before you consider making any modifications or adding an accessory, be sure to read the following information.

⚠ WARNING

Improper accessories or modifications can cause a crash in which you can be seriously hurt or killed.

Follow all instructions in this owner's manual regarding accessories and modifications.

Accessories

We strongly recommend that you use only genuine Honda accessories that have been specifically designed and tested for your ATV. Because Honda cannot test all other accessories, you must be personally responsible for proper selection, installation, and use of non-Honda accessories.

Check with your Honda dealer for assistance and always follow these guidelines:

- Make sure the accessory does not obscure any lights, reduce ground clearance, limit suspension travel or steering travel, or interfere with operating any controls.
- Make sure the accessory does not interfere with your ability to shift body position on the seat or operate hand and foot controls.
- Do not add any electrical equipment that will exceed the vehicle's electrical system capacity (page 176). A blown fuse can cause a loss of lights or engine power (page 166).

Accessories & Modifications

Modifications

We strongly advise you not to remove any original equipment or modify your ATV in any way that would change its design or operation. Such changes could seriously impair your ATV's handling, stability, and braking, making it unsafe to ride.

We also advise you not to make any modifications or remove any equipment (such as the USDA qualified spark arrester or emission control system components) that would make your ATV illegal in your area.

Removing or modifying your lights, exhaust system, emission control system, or other equipment can also make your ATV illegal.

Basic Operation & Riding

This section gives basic riding instructions, including how to start and stop your engine, and how to use the throttle and brakes. It also provides important information on riding with cargo.

To protect your new engine and enjoy optimum performance and service life, refer to Break-in Guidelines (page 178).

For information about carburetor adjustment for riding at high altitude, see page 179.

Safe Riding Precautions	43
Off-Road Use Only	43
Keeps Hands and Feet on Controls	44
Control Speed.....	45
Use Care on Unfamiliar or Rough Terrain.....	46
Do Not Perform Stunts.....	47
Starting & Stopping the Engine	48
Preparation	48
Starting Procedure	49
Flooded Engine	52
How to Stop the Engine	52
Using the Recoil Starter	53
Shifting Gears	54
Riding in Reverse.....	56

(cont'd)

Basic Operation & Riding

Braking.....	58
Riding Your ATV	60
Making Turns.....	60
Skidding or Sliding	62
Riding Up Hills	63
Riding Down Hills	67
Crossing or Turning on Hills or Slopes.....	68
Riding Over Obstacles	70
Riding Through Water	71
Parking	72

Safe Riding Precautions

Before riding your ATV for the first time, please review the *ATV Safety* section beginning on page 1, and the *Before Riding* section beginning on page 27.

Even if you have ridden other ATVs, take time to become familiar with how this ATV works and handles. Practice in a safe area until you build your skills and get accustomed to the ATV's size and weight.

Off-Road Use Only

Your ATV and its tires are designed and manufactured for off-road use only, not for pavement. Riding on pavement can affect handling and control. You should not ride your ATV on pavement.

WARNING

Operating this ATV on paved surfaces may seriously affect handling and control of the ATV, and may cause the vehicle to go out of control.

Never operate the ATV on any paved surfaces, including sidewalks, driveways, parking lots and streets.

When riding off-road, also remember to always obey local off-road riding laws and regulations. Obtain permission to ride on private property. Avoid posted areas and obey “no trespassing” signs.

(cont'd)

Safe Riding Precautions

You should never ride your ATV on public streets, roads or highways, even if they are not paved. Drivers of street vehicles may have difficulty seeing and avoiding you, which could lead to a collision. In many states it is illegal to operate ATVs on public streets, roads and highways.

⚠ WARNING

Operating this ATV on public streets, roads or highways could cause you to collide with another vehicle.

Never operate this ATV on any public street, road or highway, even a dirt or gravel one.

Keep Hands and Feet on Controls

Always keep both hands on the handlebars and both feet on the footpegs when riding your ATV. This is important to maintain your balance and to control the vehicle. Removing even one hand from the handlebars or one foot from the footpegs can reduce your ability to control the ATV or could cause you to lose your balance and fall off the ATV.

⚠ WARNING

Removing hands from handlebars or feet from footpegs during operation can reduce your ability to control the ATV or could cause you to lose your balance and fall off of the ATV.

Always keep both hands on the handlebars and both feet on the footpegs of your ATV during operation.

Safe Riding Precautions

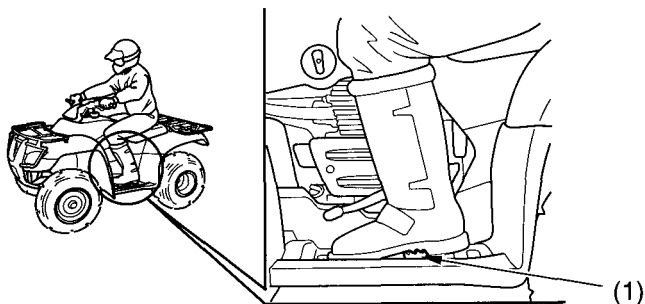

(1) foot peg

Control Speed

Riding at excessive speed increases the chance of an accident. In choosing a proper speed, you need to consider the capability of your vehicle, the terrain, visibility and other operating conditions, plus your own skills and experience.

⚠ WARNING

Operating this ATV at excessive speeds increases your chances of losing control of the ATV, which can result in an accident.

Always go at a speed that is proper for your vehicle, the terrain, visibility and other operating conditions, and your experience.

Safe Riding Precautions

Use Care on Unfamiliar or Rough Terrain

Before riding in a new area, always check the terrain thoroughly. Don't ride fast on unfamiliar terrain or when visibility is limited. (It's sometimes difficult to see obstructions like hidden rocks, bumps, or holes in time to react.)

WARNING

Failure to use extra care when operating this ATV on unfamiliar terrain could result in the ATV overturning or going out of control.

Go slowly and be extra careful when operating on unfamiliar terrain. Always be alert to changing terrain conditions when operating the ATV.

Safe Riding Precautions

Never ride past the limit of visibility. Maintain a safe distance between your ATV and other off-road vehicles. Always exercise caution, and use extra care on rough, slippery and loose terrain.

WARNING

Failure to use extra care when operating on excessively rough, slippery or loose terrain could cause loss of traction or vehicle control, which could result in an accident, including an overturn.

Do not operate on excessively rough, slippery or loose terrain until you have learned and practiced the skills necessary to control the ATV on such terrain. Always be especially cautious on these kinds of terrain.

Do Not Perform Stunts

You should always operate your ATV in a safe and reasonable manner. When riding, always keep all four wheels on the ground.

WARNING

Attempting wheelies, jumps, and other stunts increases the chance of an accident, including an overturn.

Never attempt stunts, such as wheelies or jumps. Don't try to show off.

Starting & Stopping the Engine

Always follow the proper starting procedure described below.

For your safety, avoid starting or operating the engine in an enclosed area such as a garage. Your ATV's exhaust contains poisonous carbon monoxide gas which can collect rapidly in an enclosed area and cause illness or death.

Preparation

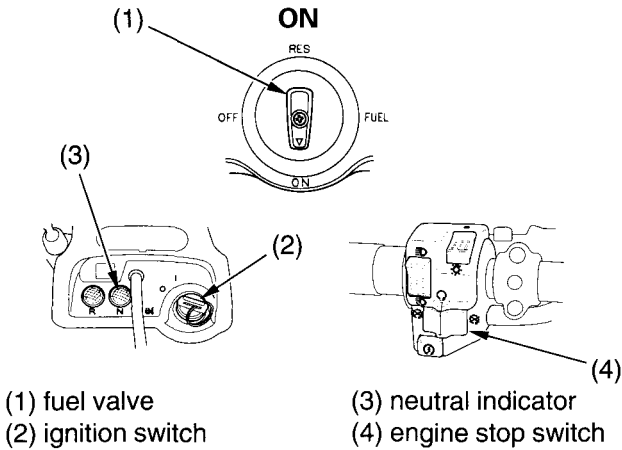

1. Before starting, select a level surface and lock the parking brake (page 24).
2. Turn the fuel valve (1) and ignition switch (2) to ON (|).

Confirm the following:

- The transmission is in NEUTRAL (neutral indicator (3) ON).
- The engine stop switch (4) is set to RUN (◯).

Starting & Stopping the Engine

Starting Procedure

To restart a warm engine, follow the procedure for “*High Air Temperature.*”

The starter motor will operate only when the transmission is in neutral.

Normal Air Temperature 10° – 35°C (50° – 95°F)

LEFT HANDLEBAR

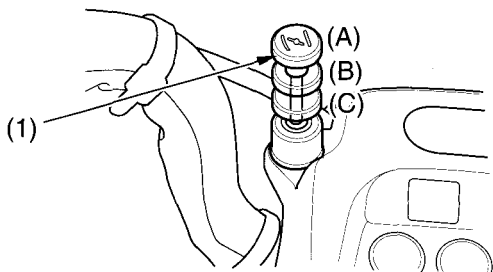

(1) choke knob

(A) fully ON

(B) halfway position

(C) fully OFF

1. Pull the choke knob (1) up all the way to fully ON (A) position, if the engine is cold.
 2. With the throttle slightly open, press the start button.
- Pressing the electric start button for more than 5 seconds at a time may cause the starter to overheat and damage the starter. Release the start button for approximately 10 seconds before pressing it again.

(cont'd)

Starting & Stopping the Engine

3. Immediately after the engine starts, push the choke knob down to the halfway position (B).
4. Warm up the engine by opening and closing the throttle slightly.
5. After the engine has warmed up, push the choke knob down all the way to fully OFF (C).
6. If idling is unstable, open the throttle slightly.

High Air Temperature 35°C (95°F) or above

LEFT HANDLEBAR

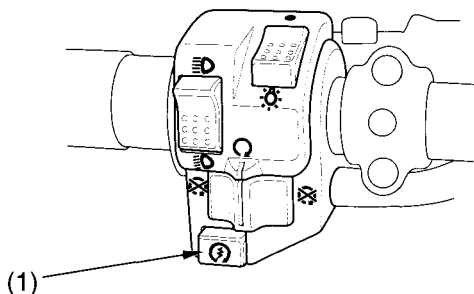

(1) start button

1. Do not use the choke.
2. With the throttle slightly open, press the start button (1).

Starting & Stopping the Engine

Low Air Temperature 10°C (50°F) or below

1. Follow steps 1 – 2 under “*Normal Air Temperature.*”
2. Warm up the engine by opening and closing the throttle slightly.
3. When the engine begins to run slightly rough, push the choke knob down to the halfway position (B).
4. Continue warming up the engine until it runs smoothly and responds to the throttle, then push the choke knob down all the way to fully OFF (C).
5. If idling is unstable, open the throttle slightly.

If the engine doesn't start after pushing the start button several times, use the recoil starter.

NOTICE

Extended use of the choke may impair piston and cylinder wall lubrication and shorten the life of the engine.

Do not race the engine during the warm-up period.

Racing a cold engine wastes fuel and increases engine wear.

Starting & Stopping the Engine

Flooded Engine

If the engine fails to start after repeated attempts, it may be flooded with excess fuel. To clear a flooded engine:

1. Move the engine stop switch to OFF (☒).
2. Push the choke knob down all the way to fully OFF.
3. Open the throttle fully.
4. Press the start button for 5 seconds.
5. Wait 10 seconds, then turn the engine stop switch to RUN (○).
6. Repeat the “*Normal Air Temperature*” starting procedure, but don’t use the choke.

If the engine still won’t start, refer to *If Your Engine Quits or Won’t Start*, page 160.

How to Stop the Engine

Normal Engine Stop

To stop the engine, make sure the transmission is in neutral by checking that the neutral indicator lights, and turn the ignition switch OFF.

The engine stop switch should normally remain in the RUN (○) position even when the engine is OFF.

If your ATV is stopped with the engine stop switch OFF (☒) and the ignition switch ON (|), the battery will discharge.

Emergency Engine Stop

To stop the engine in an emergency, use the engine stop switch. To operate, move the switch to either OFF (☒) position.

Starting & Stopping the Engine

Using the Recoil Starter

The recoil starter is used to start the engine when the battery is low.
To operate the recoil starter:

1. Grasp the starter grip (1) firmly, then pull it out slowly approximately 4 in (100 mm).
2. Pull the grip up briskly and fully.
3. After the engine starts, allow the starter grip to return slowly.

Pull the recoil starter grip straight out so that the cord does not touch the side cover. Repeated contact with the side cover can damage the starter cord.

If the starter grip does not return smoothly (because of dirt in the assembly), see your Honda dealer.

LEFT SIDE

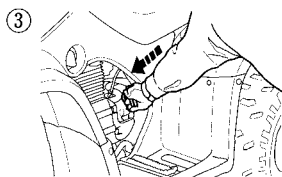
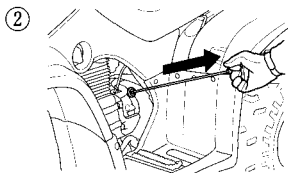
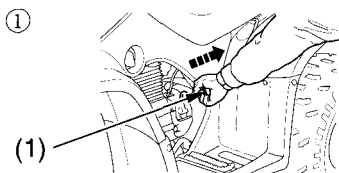

(1) recoil starter grip

Shifting Gears

UPSHIFTING SEQUENCE

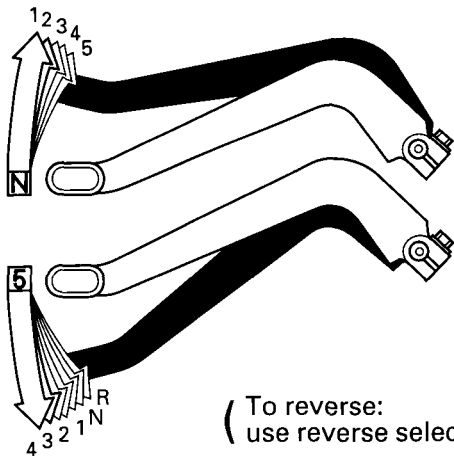

DOWNSHIFTING SEQUENCE

Your ATV has five forward gears: 1, 2, 3, 4, and 5.

The shift lever is located near the left footpeg. One full stroke of the shift lever shifts the transmission to the next higher or lower gear in the shifting sequence. The shift lever automatically returns to the horizontal position when released.

To upshift to a higher gear, put the toe of your boot under the shift lever and raise it one full stroke. To downshift, step on the shift lever and depress it one full stroke.

Shifting Gears

After starting the engine and letting it warm up, follow these procedures:

1. With the transmission in neutral, release the parking brake, but continue squeezing the rear brake lever.
2. With the throttle closed, raise the shift lever one full stroke to shift into 1st gear.
3. Release the rear brake lever and increase engine speed by gradually opening the throttle.
4. When speed increases, release the throttle and shift to 2nd gear by raising the shift lever one full stroke.
5. Repeat this sequence to progressively upshift to 3rd, 4th and 5th (top) gear.
6. To downshift, reverse this sequence. Remember to close the throttle each time you shift to the next lower gear.

Learning when to shift gears comes with experience. Keep the following tips in mind:

- As a general rule, shift while moving in a straight line.
- Close the throttle completely before shifting. Improper shifting may damage the engine, transmission, and drive train.
- Upshift to a higher gear or reduce throttle before engine rpm (speed) gets too high. Learn the relationship between engine sound and the normal shifting points.
- Downshift to a lower gear before you feel the engine laboring (lugging) at low rpm.
- Avoid downshifting to help slow your ATV when engine rpm is high. Downshifting when engine speed is near its allowable maximum may over-rev the engine and cause possible damage.
- To prevent transmission damage, do not coast or tow the ATV for long distances with the engine off.
- Ride in the highest gear that lets the engine run and accelerate smoothly. This will give you good fuel economy and effective emissions control.

Riding in Reverse

If you need to ride in reverse, make sure the area behind you is clear and only operate the ATV at low speed.

⚠ WARNING

Improperly operating in reverse could cause you to hit an obstacle or person behind you, resulting in serious injury.

Make sure there are no obstacles or people behind you before selecting reverse gear. When it is safe to proceed, go slowly.

1. Bring the vehicle to a complete stop, then make sure the transmission is in neutral.
2. Be sure there are no obstacles or people in the way.
3. While pushing the reverse selector knob (1) in, squeeze the rear brake lever (2), then depress the shift lever.
4. Release the rear brake lever.
5. Open the throttle gradually and ride slowly. Do not open the throttle suddenly or make abrupt turns.

LEFT HANDLEBAR

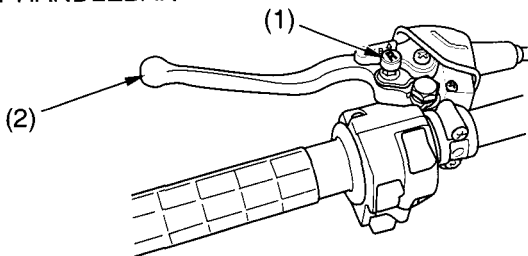

(1) reverse selector knob

(2) rear brake lever

Riding in Reverse

6. To stop, close the throttle and gradually apply both the front and rear brakes. Do not abruptly apply the rear brake by itself.
7. To shift out of reverse and into neutral, raise the shift lever one stroke.

WARNING

Applying only the rear brake abruptly when operating in reverse gear could cause the front wheels to lift off the ground and the ATV could overturn backwards.

Carefully apply both the front and rear brakes when stopping in reverse gear.