

**2003
Honda TRX350FM
FOURTRAX 350 4×4
OWNER'S MANUAL**

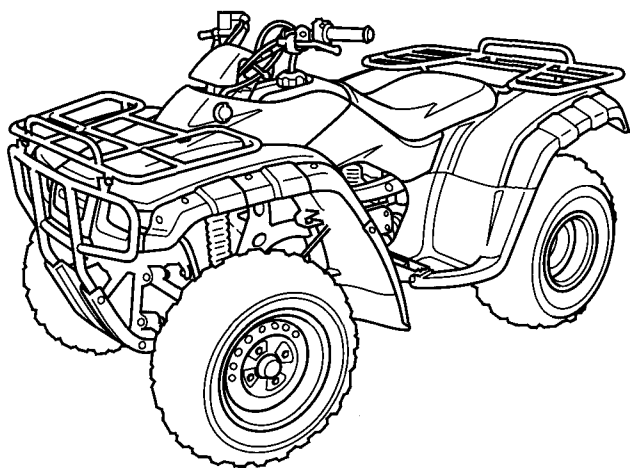

Introduction

Congratulations on choosing your Honda ATV.

When you own a Honda, you're part of a worldwide family of satisfied customers — people who appreciate Honda's reputation for building quality into every product.

Your Honda was designed as a recreational ATV for off-road use by one rider only.

Before riding, take time to get acquainted with your ATV and how it works. To protect your investment, we urge you to take responsibility for keeping your ATV well maintained. Scheduled service is a must, of course. But it's just as important to observe the break-in guidelines, and perform all pre-ride and other periodic checks detailed in this manual.

We also recommend that you read this owner's manual before you ride. It's full of facts, instructions, safety information, and helpful tips. To make it easy to use, the manual contains a detailed list of topics at the beginning of each section, and both an in-depth table of contents and an index at the back of the book.

As you read this manual, you will find information that is preceded by a **NOTICE** symbol. This information is intended to help you avoid damage to your Honda, other property, or the environment.

Read the Warranties Booklet (page 203) thoroughly so you understand the coverages that protect your new Honda and are aware of your rights and responsibilities.

Whenever you ride, tread lightly. By staying on established trails and riding only in approved areas, you help protect the environment and keep off-road riding areas open for the future.

Introduction

If you have any questions, or if you ever need special service or repairs, remember that your Honda dealer knows your ATV best and is dedicated to your complete satisfaction.

Please report any change of address or ownership to your Honda dealer so we will be able to contact you concerning important production information.

You may also want to visit our website at www.honda.com.

Happy riding!

California Proposition 65 Warning

WARNING: This product contains or emits chemicals known to the State of California to cause cancer and birth defects or other reproductive harm.

A Few Words About Safety

Your safety, and the safety of others, is very important. And operating this ATV safely is an important responsibility.

To help you make informed decisions about safety, we have provided operating procedures and other information on labels and in this manual. This information alerts you to potential hazards that could hurt you or others.

Of course, it is not practical or possible to warn you about all hazards associated with operating or maintaining an ATV. You must use your own good judgment.

You will find important safety information in a variety of forms, including:

Safety Labels — on the ATV.

Safety Messages — preceded by a safety alert symbol  and one of three signal words: **DANGER**, **WARNING**, or **CAUTION**.

A Few Words About Safety

These signal words mean:

▲ DANGER

You **WILL** be **KILLED** or **SERIOUSLY HURT** if you don't follow instructions.

▲ WARNING

You **CAN** be **KILLED** or **SERIOUSLY HURT** if you don't follow instructions.

▲ CAUTION

You **CAN** be **HURT** if you don't follow instructions.

Safety Headings — such as Important Safety Reminders or Important Safety Precautions.

Safety Section — such as ATV Safety.

Instructions — how to use this ATV correctly and safely.

This entire manual is filled with important safety information — please read it carefully.

Contents

These pages give an overview of the contents of your owner's manual. The first page of each section lists the topics covered in that section.

ATV Safety	1
Important safety information you should know, plus a look at the safety-related labels on your ATV.	
Instruments & Controls.....	9
The location and function of indicators and controls on your ATV and operating instructions for various controls and features.	
Before Riding.....	35
The importance of wearing a helmet and other protective gear, how to make sure you and your ATV are ready to ride, and important information about loading.	
Basic Operation & Riding	49
How to start and stop the engine, shift gears, and brake. Also, riding precautions.	

Contents

Servicing Your Honda	81
Why your ATV needs regular maintenance, what you need to know before servicing your Honda, an owner maintenance schedule, and instructions for specific maintenance and adjustment items.	
Tips	159
How to store and transport your ATV and how to be an environmentally-responsible rider.	
Taking Care of the Unexpected	169
What to do if you have a flat tire, your engine won't start, etc.	
Technical Information	185
ID numbers, technical specifications, and other technical facts.	
Consumer Information	199
Information on warranties, emission controls, how to get Honda service manuals.	
Table of Contents	208
Sequential listing of topics in this owner's manual.	
Index	214
Quick Reference	
Handy facts about fuel, engine oil, tire sizes, and air pressures.	

ATV Safety

This section presents some of the most important information and recommendations to help you ride your ATV safely. Please take a few moments to read these pages. This section also includes information about the location of safety labels on your ATV.

Important Safety Information	2
Safety Labels.....	5

Important Safety Information

Your ATV can provide many years of service and pleasure — if you take responsibility for your own safety and understand the challenges you can meet while riding.

There is much that you can do to protect yourself when you ride. You'll find many helpful recommendations throughout this manual. The following are a few that we consider most important.

Follow the Age Recommendation

The minimum recommended age for this ATV model is 16. Children under age 16 should never operate this vehicle.

Always Wear a Helmet

It's a proven fact: helmets significantly reduce the number and severity of head injuries. So always wear an approved motorcycle helmet. We also recommend that you wear eye protection, sturdy boots, gloves, and other protective gear (page 36).

Never Carry a Passenger

Your ATV is designed for one person only. There are no handholds, footrests, or seat for a second person — so never carry a passenger. A passenger could interfere with your ability to move around to maintain your balance and control of the ATV.

Important Safety Information

Ride Off-Road Only

Your ATV is designed and manufactured for off-road use only. The tires are not made for pavement, and the ATV does not have turn signals and other features required for use on public roads. If you need to cross a paved or public road, get off and walk your ATV across.

Take Time to Learn & Practice

Even if you have ridden other ATVs, take time to become familiar with how this ATV works and handles. Practice in a safe area until you build your skills and get accustomed to the ATV's size and weight.

Because many accidents involve inexperienced or untrained riders, we urge all riders to take a training course approved by the ATV Safety Institute (ASI). See page 38.

Contact an authorized ATV dealer or call 1-800-887-2887 (USA only) to find out about the training courses nearest you.

Be Alert for Off-Road Hazards

The terrain can present a variety of challenges when you ride off-road. Continually “read” the terrain for unexpected turns, drop-offs, rocks, ruts, and other hazards. Always keep your speed low enough to allow time to see and react to hazards.

Important Safety Information

Ride within Your Limits

Pushing limits is another major cause of ATV accidents. Never ride beyond your personal abilities or faster than conditions warrant. Remember that alcohol, drugs, fatigue, and inattention can significantly reduce your ability to make good judgments and ride safely.

Don't Drink and Ride

Alcohol and riding don't mix. Even one drink can reduce your ability to respond to changing conditions, and your reaction time gets worse with every additional drink. So don't drink and ride, and don't let your friends drink and ride either.

Keep Your Honda in Safe Condition

It's important to keep your ATV properly maintained and in safe riding condition. Having a breakdown can be difficult, especially if you are stranded off-road far from your base. To help avoid problems, inspect your ATV before every ride and perform all recommended maintenance.

Safety Labels

Your ATV comes with a hang tag and several labels containing important safety information. Anyone who rides the vehicle should read and understand this information before riding.

The labels should be considered permanent parts of the vehicle. If a label comes off or becomes hard to read, contact your Honda dealer for replacements.

Safety Labels

USA only

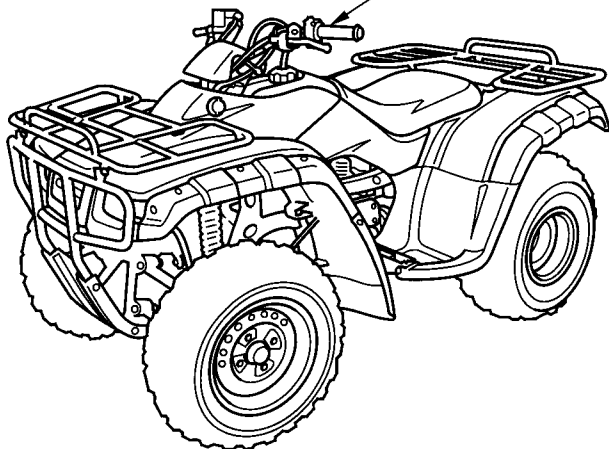
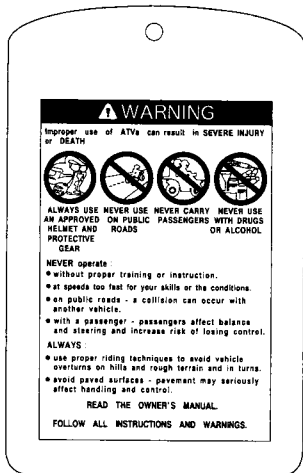

Safety Labels

WARNING



NEVER ride as a passenger.
Passengers can cause a
loss of control, resulting in
SEVERE INJURY or DEATH.

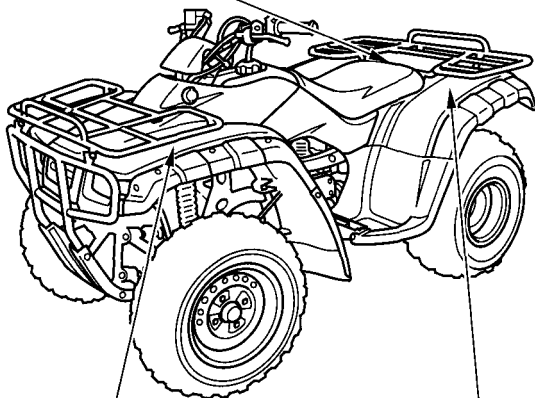

WARNING

Overloading this ATV or carrying cargo improperly can change handling, stability and braking performance and can lead to an accident.

Never exceed the maximum front cargo limit of: **66lbs (30kg)**.

Refer to instructions in the Owner's Manual.

WARNING

Improper tire pressure or overloading can cause loss of control. Loss of control can result in severe injury or death.

- Cold tire pressure ;
Front : 25±3kpa 0.25±0.03kgf/cm² 3.6±0.4psi
Rear : 25±3kpa 0.25±0.03kgf/cm² 3.6±0.4psi
- Maximum weight capacity ; 220kg 485lbs.

Safety Labels

⚠ WARNING

UNDER 16

Operating this ATV if you are under the age of 16 increases your chance of severe injury or death.

NEVER operate this ATV if you are under age 16.

BRAKING INFORMATION

With four-wheel drive operating any brake control causes braking at both the front and rear wheels. For detailed braking information, refer to the Owner's Manual.

⚠ WARNING

Overloading this ATV or carrying cargo improperly can change handling, stability and braking performance and can lead to an accident.

Never exceed the maximum rear cargo limit (combined weight on the rear rack and in the storage area) of: **133lbs (60kg)**.

Refer to instructions in the Owner's Manual.

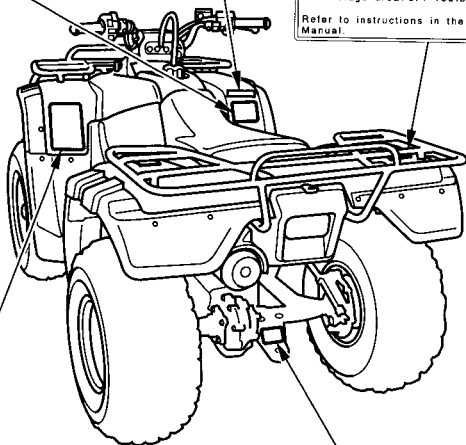

⚠ WARNING

Improper use of ATVs can result in SEVERE INJURY or DEATH

ALWAYS USE AN APPROVED HELMET AND PROTECTIVE GEAR **NEVER USE ON PUBLIC ROADS** **NEVER CARRY PASSENGERS** **NEVER USE WITH DRUGS OR ALCOHOL**

NEVER operate:

- without proper training or instruction.
- at speeds too fast for your skills or the conditions.
- on public roads - a collision can occur with another vehicle.
- with a passenger - passengers affect balance and steering and increase risk of losing control.

ALWAYS:

- use proper riding techniques to avoid vehicle overturns on hills and rough terrain and in turns.
- avoid paved surfaces - pavement may seriously affect handling and control.

READ THE OWNER'S MANUAL.

FOLLOW ALL INSTRUCTIONS AND WARNINGS.

⚠ WARNING

Towing an improperly loaded trailer can cause loss of control.

- Read owner's manual.
- Tow weight limit : 3776N (385kg/ 850lbs)
- Tongue weight : 137N (14kg/ 30lbs)

Instruments & Controls

This section shows the location of all indicators and controls you would normally use before or while riding your ATV.

The items listed on this page are described in this section. Instructions for other components are presented in other sections of this manual where they will be most useful.

Component Locations	11
Indicators & Display (Canada only).....	14
Multi-function Display (Canada only)	17
Odometer (Canada only)	18
Tripmeter (Canada only)	18
Hourmeter (Canada only).....	19
Digital Clock (Canada only)	20
Fuel Gauge	21

(cont'd)

Instruments & Controls

Control and Features

Fuel Valve	22
Choke Knob	23
Ignition Switch	24
Start Button	25
Engine Stop Switch	25
Headlight Switch	26
Headlight Dimmer Switch	26
Starting Primer Knob	27
Recoil Starter	27
Throttle Lever	28
Reverse Selector Knob	29
Front Brake Lever	30
Rear Brake Lever	30
Rear Brake Pedal	30
Parking Brake	30
Flag Pole Bracket	31
Trailer Hitch	32
Accessory Socket	33

Component Locations

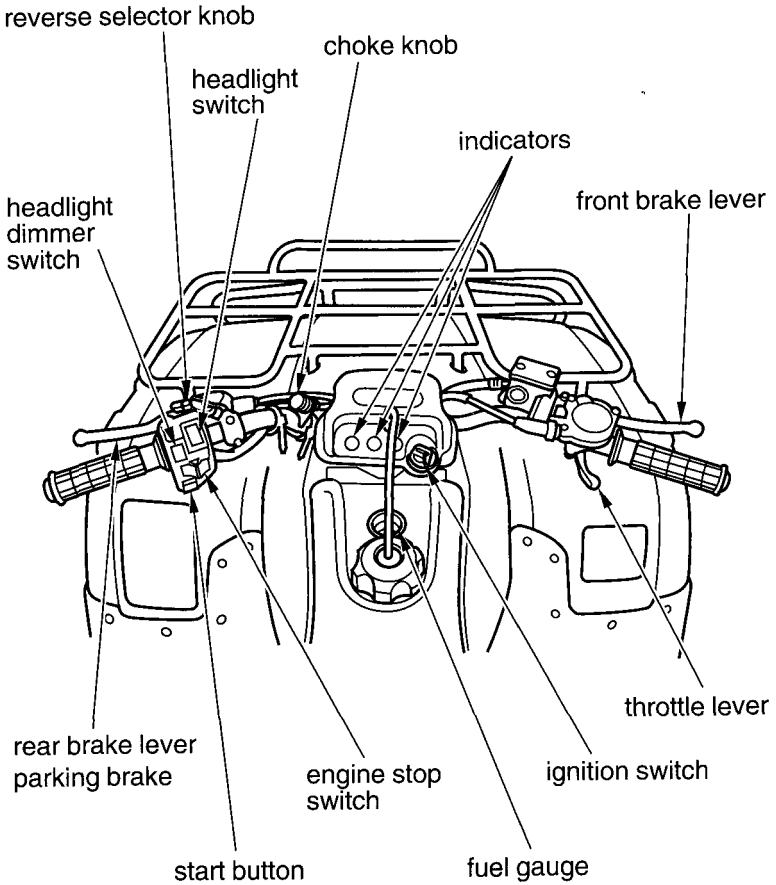

Component Locations

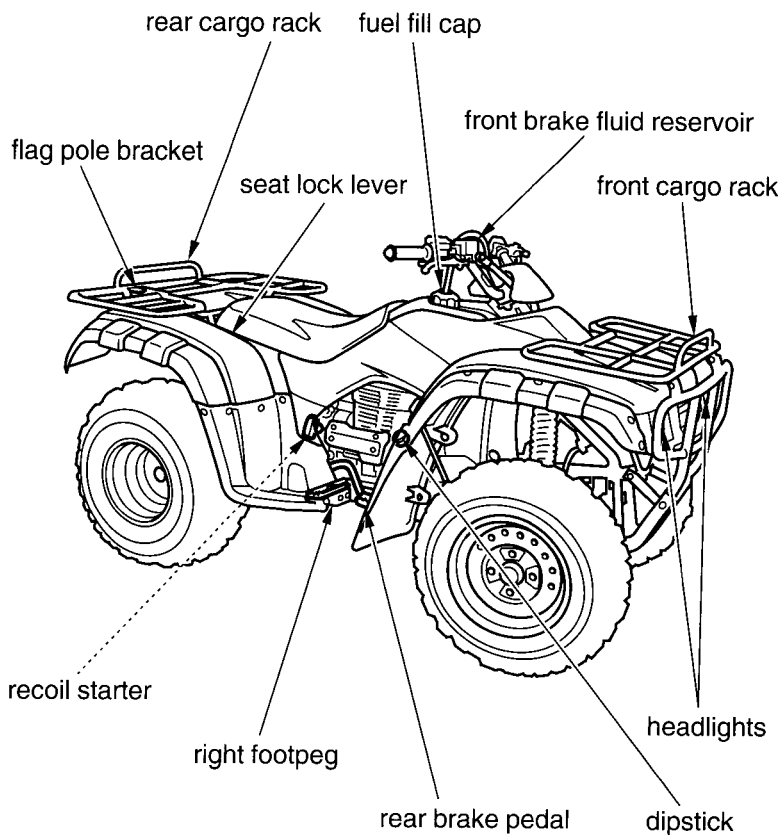

Component Locations

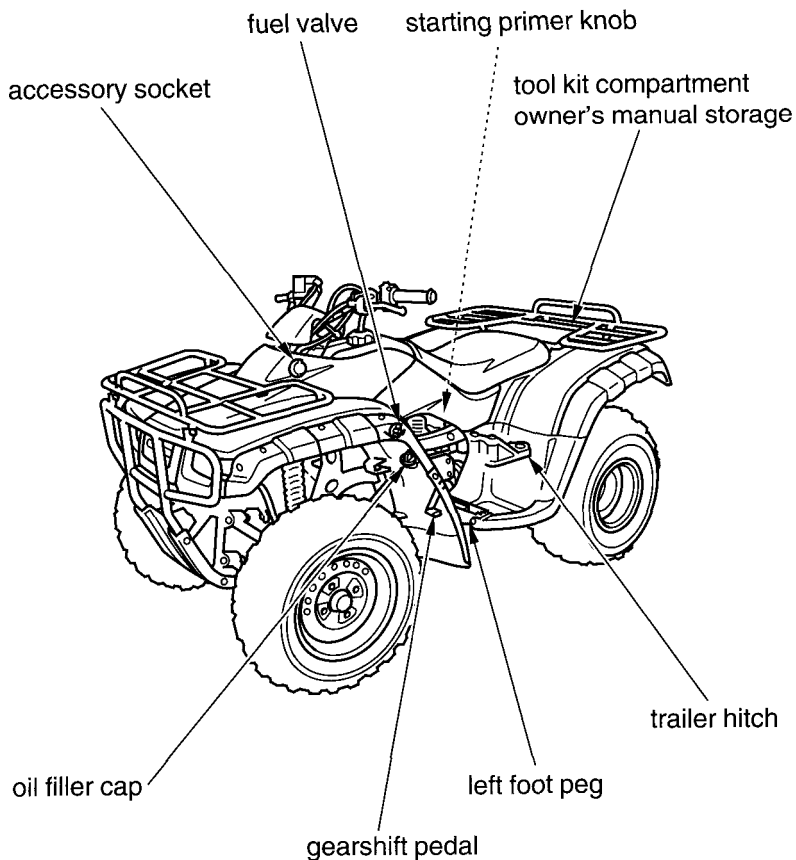

Indicators & Display

The indicators and displays on your ATV keep you informed, alert you to possible problems, and make your riding safer and more enjoyable. Refer to the indicators frequently. Their functions are described on the following pages.

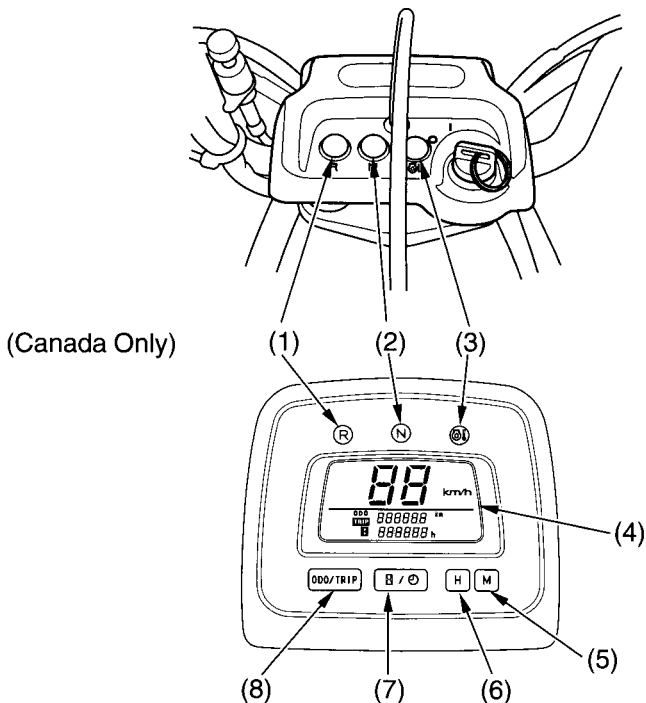

- | | |
|------------------------------------|---|
| (1) reverse indicator | (5) minute select button |
| (2) neutral indicator | (6) hour select button |
| (3) oil high temperature indicator | (7) hourmeter/digital clock select button |
| (4) multi-function display | (8) odometer/tripmeter select button |

Indicators & Display

Lamp Check

The oil high temperature indicator comes on when you turn the ignition switch ON so you can check that it is working. The indicator remains on until after the engine is started.

This indicator is identified in the table on page 16 with the words: *Lamp Check*.

When applicable, the reverse and neutral indicators come on when you turn the ignition switch ON and remain on until you shift out of reverse or neutral.

If one of these indicators does not come on when it should, have your Honda dealer check for burned-out bulbs or other problems.

Display Check (Canada only)

When the ignition switch is turned ON (I), the multi-function display (4) will temporarily show all the modes and digital segments so you can make sure the liquid crystal display is functioning properly.

The displays are identified in the table on page 16 with the words: *Display Check*.

If any part of these displays does not come on when it should, have your Honda dealer check for problems.

Indicators & Display

1	Reverse indicator	Lights when the transmission is in reverse. <i>Lamp Check</i>
2	Neutral indicator	Lights when the transmission is in neutral. <i>Lamp Check</i>
3	Oil high temperature indicator	Lights when engine oil temperature is high enough to adversely affect the service life of the engine. If the oil high temperature indicator comes on while you are riding, immediately bring the vehicle to a stop, turn the engine off and let it cool. See page 178. <i>Lamp Check</i>
(below Canada only)		
4	Multi-function display	The display includes the following functions. <i>Display Check</i> .
	Speedometer	Shows riding speed.
	Odometer	Shows accumulated mileage (page 18).
	Tripmeter	Shows mileage per trip (page 18).
	Hourmeter	Shows hours and tenths of hours of engine operation (page 19).
	Digital clock	Shows the time (hours and minutes) (page 20).
5	Odometer/tripmeter select button	Selects display of the odometer or tripmeter. Resets the tripmeter to zero (0) (page 18).
6	Hourmeter/digital clock select button	Selects display of the hourmeter or digital clock (pages 19, 20).
7	Hour select button	Advances the hour displayed by the digital clock (page 20).
8	Minute select button	Advances the minutes displayed by the digital clock (page 20).

Indicators & Display

Multi-function Display (Canada only)

The multi-function display (1) includes the following functions:

- Speedometer
- Odometer
- Tripmeter
- Digital clock
- Hourmeter

The digital clock will reset if the battery is disconnected.

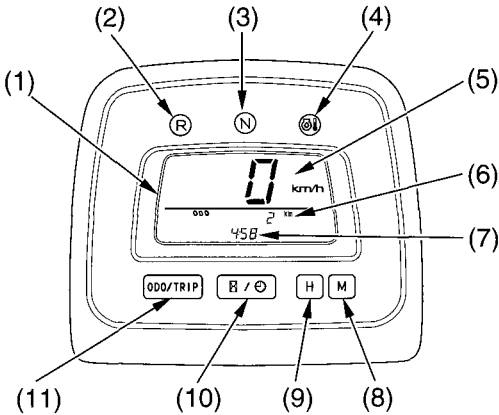

- | | |
|------------------------------------|--|
| (1) multi-function display | (7) digital clock/hourmeter |
| (2) reverse indicator | (8) minute select button |
| (3) neutral indicator | (9) hour select button |
| (4) oil high temperature indicator | (10) digital clock/hourmeter select button |
| (5) speedometer | (11) odometer/tripmeter select button |
| (6) odometer | |

Indicators & Display

Odometer (Canada only)

When selected, the odometer (1) registers total distance traveled in miles while the ignition is ON (1). To change the display from tripmeter to odometer, press and release the Odometer/Tripmeter select button (2).

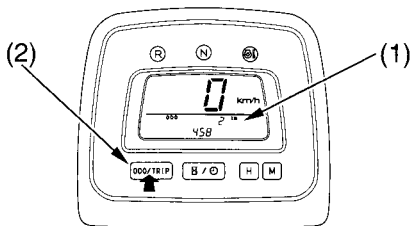

(1) odometer (2) odometer/tripmeter select button

Tripmeter (Canada only)

When selected, the tripmeter (3) shows mileage per trip while the ignition is ON (1). To change the display from odometer to tripmeter, press and release the Odometer/Tripmeter select button (2). To reset the tripmeter to zero, press the Odometer/Tripmeter select button and hold it in for at least two seconds.

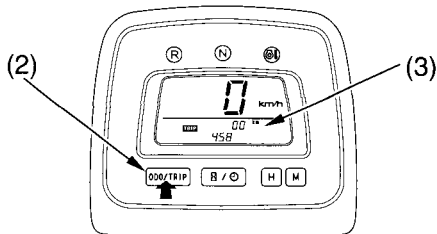

(3) tripmeter

Indicators & Display

Hourmeter (Canada only)

When selected, the hourmeter (1) shows accumulated hours while the ignition is ON (I). The hourmeter provides accurate service period information for initial and regular maintenance. To change the display from the digital clock to the hourmeter, press and release the hourmeter/digital clock select button (2). The hourmeter mark (3) will appear.

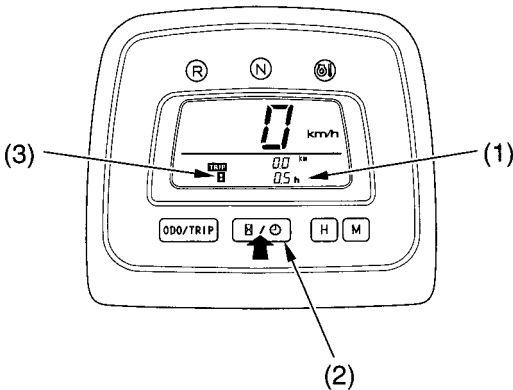

(1) hourmeter

(3) hourmeter mark

(2) hourmeter/digital clock
select button

Indicators & Display

Digital Clock (Canada only)

Shows hour and minute while the ignition is ON (1).

To change the display from hourmeter to digital clock, press and release the hourmeter/digital clock select button (1).

To adjust the time, proceed as follows:

1. Turn the ignition switch ON (1).
2. To advance the hour display one unit at a time, press and release the hour select button (2).
To advance the hour display automatically, press and hold the hour select button. After two seconds, the hour display will begin advancing. Release the button when the display reaches the desired hour.
3. To advance the minute display one unit at a time, press and release the minute select button (3).
To advance the minute display automatically, press and hold the minute select button. After two seconds, the minute display will begin advancing. Release the button when the display reaches the desired minute.
4. To zero the minute display, press and hold both the hour and minute buttons simultaneously for two seconds.

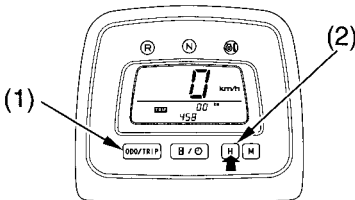

(1) hourmeter/digital clock select button

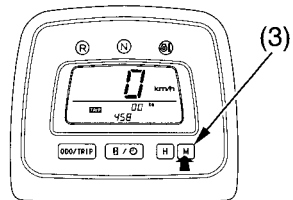

(2) hour select button
(3) minute select button

Indicators & Display

Fuel Gauge

The fuel gauge (1) shows the approximate fuel supply available. At F (Full), the fuel tank capacity including reserve is:

3.43 US gal (13.0 l , 2.86 Imp gal)

When the gauge needle (2) enters the red band (3), fuel will be low and you should refill the tank as soon as possible. The amount of fuel left in the tank when the needle enters the red band is approximately:

0.85 US gal (3.2 l , 0.70 Imp gal)

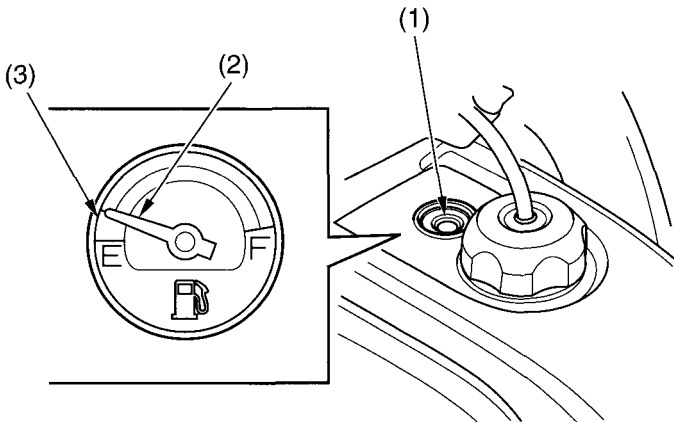

(1) Fuel gauge

(2) Gauge needle

(3) Red band

Controls & Features

Fuel Valve

LEFT SIDE

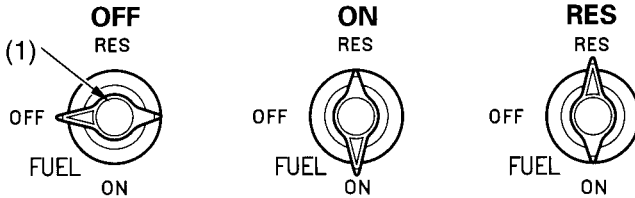

(1) fuel valve

The manual fuel valve is located on the left side under the fuel tank.

The three-way fuel valve is used to control the flow of fuel from the fuel tank to the carburetor.

ON — normal position for riding.

OFF — for parking, storing, or transportation.

RES — for extra fuel to get to a gas supply for refueling.

Reserve Fuel

Remember to check that the fuel valve is in the ON position each time you refuel. If the valve is left in the RES position, you may run out of fuel with no reserve.

For complete information about fueling your ATV, see page 98 .

Controls & Features

Choke Knob



LEFT HANDLEBAR

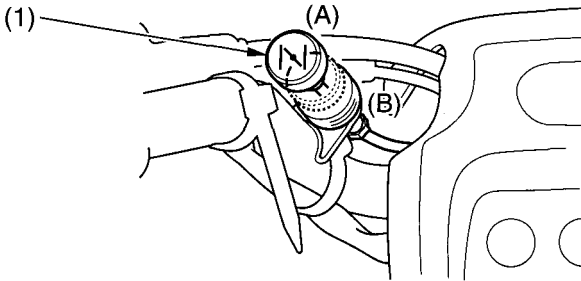

(1) choke knob

(A) fully ON
(B) fully OFF

The choke knob may be used when starting the engine. See page 57 .

Controls & Features

Ignition Switch

The ignition switch is used for starting and stopping the engine (page 56). Insert the key and turn it to the right for the ON position.

Key Position	Function
ON (I)	Electrical circuits on.
OFF (O)	No electrical circuits function.

CENTER OF HANDLEBAR

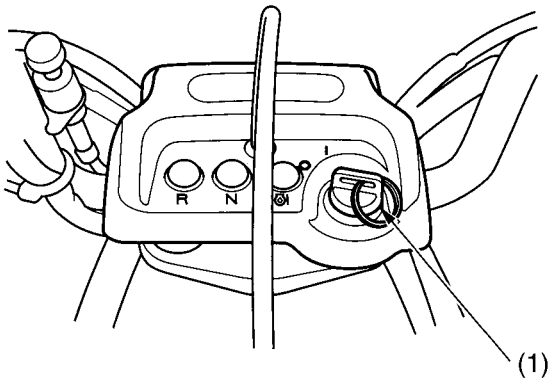

(1) ignition switch

I ON
O OFF

Controls & Features

Start Button



LEFT HANDLEBAR

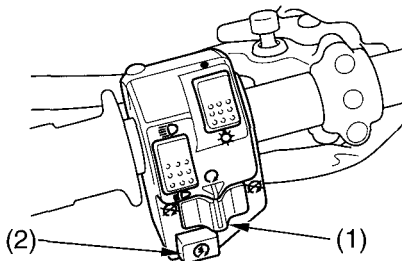

(1) start button

(2) engine stop switch

⚡ START

⊗ OFF

○ RUN

The start button (1) is used for starting the engine. Pushing the button in starts the engine. See *Starting Procedure*, page 57 .

When the start button is pushed, the starter motor will crank the engine. The starter motor will not operate if the engine stop switch is in the OFF position when the start button is pushed.

Engine Stop Switch



The engine stop switch (2) is used to stop the engine in an emergency. To operate, push the switch to either OFF position. The switch must be in the RUN position to start the engine, and it should normally remain in the RUN position even when the engine is OFF.

If your ATV is stopped with the ignition switch ON and the engine stop switch OFF, the battery will discharge. Turn the ignition switch OFF to prevent battery discharge.

Controls & Features

Headlight Switch

LEFT HANDLEBAR

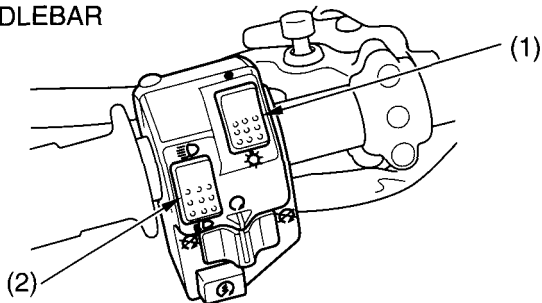

(1) headlight switch

(2) headlight dimmer switch

☀ ON
● OFF
≡D HI
≡D LOW

The headlight switch (1) is used to turn the headlight ON (☀) or OFF (●). To operate, turn the switch to ON (☀) or OFF (●).

Headlight Dimmer Switch



The headlight dimmer switch (2) is used to change between the high and low beams of the headlight. To operate, turn the switch to HI (≡D) for high beam, LO (≡D) for low beam.

Controls & Features

Starting Primer Knob

LEFT SIDE

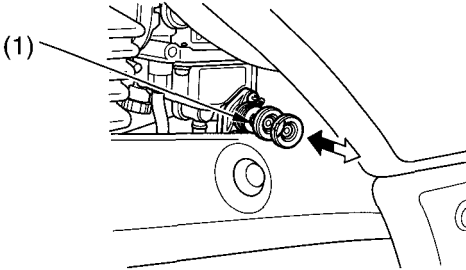

(1) starting primer knob

The starting primer knob (1) is located on the carburetor float bowl. The knob may be used when starting the engine in extremely cold weather (-15°C , 5°F). See *Starting Procedure*, page 57 .

Recoil Starter

RIGHT SIDE

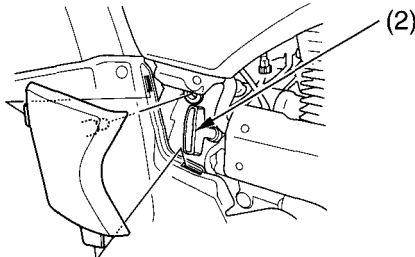

(2) recoil starter

The recoil starter (2) is used to start the engine when the battery is low. See *Using the Recoil Starter*, page 60 .

Controls & Features

Throttle Lever

RIGHT HANDLEBAR

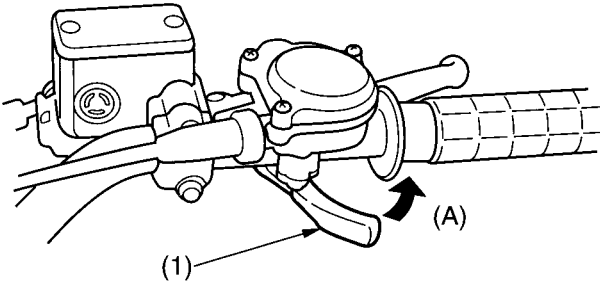

(1) throttle lever

(A) to open the throttle

The throttle controls rpm (speed). To increase engine rpm, press the lever (1) with your thumb. To reduce engine rpm, release pressure on the lever. The throttle will automatically return to the closed position (engine idle) when you remove your thumb.

Controls & Features

Reverse Selector Knob

The reverse selector knob (1), located on the rear brake lever (2), is used to shift into reverse. To operate, with your ATV stopped and the transmission in neutral, push in the knob, squeeze the rear brake lever, then depress the gearshift pedal. See *Riding in Reverse*, page 63 .

LEFT HANDLEBAR

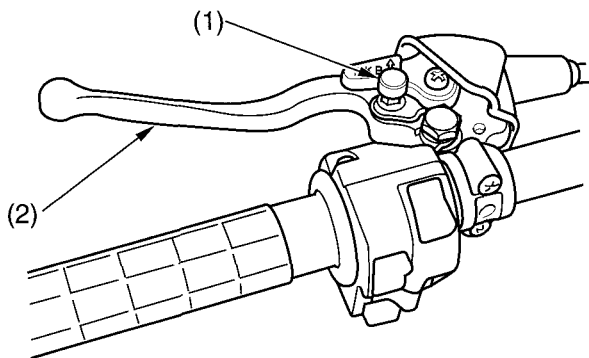

(1) reverse selector knob

(2) rear brake lever

Controls & Features

Front Brake Lever

The front brake lever is used to slow or stop your ATV. To operate, pull the lever. For information on braking techniques, see page 65.

Rear Brake Lever

The rear brake lever is used to slow or stop your ATV. To operate, pull the lever. For information on braking techniques, see page 65.

Rear Brake Pedal

The rear brake pedal is used to slow or stop your ATV. To operate, depress the pedal. For information on braking techniques, see page 65.

Parking Brake

LEFT HANDLEBAR

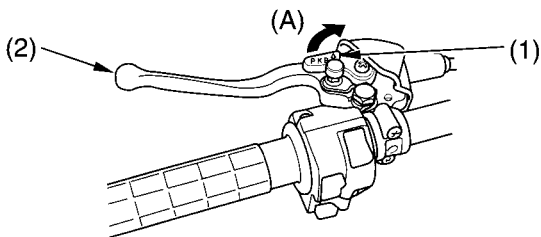

(1) lock lever

(A) to lock

(2) rear brake lever/
parking lever

The lock lever (1) on the rear brake lever (2) allows it to be used as a parking brake. To operate, first squeeze the rear brake lever and then lock it with the lock lever. See *Parking* page 79.

Controls & Features

Flag Pole Bracket

RIGHT REAR

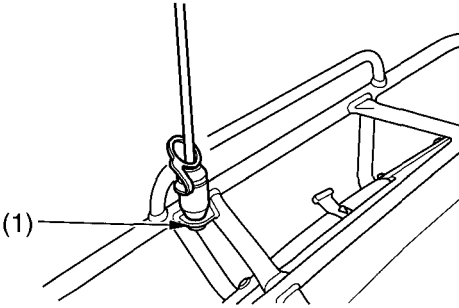

(1) flag pole bracket

Flag poles are optional equipment available from your Honda dealer. To mount a pole in the bracket (1), follow the instructions that come with the flag pole kit.

Flag poles are required in some riding areas. Check local regulations before riding.

Controls & Features

Trailer Hitch

REAR

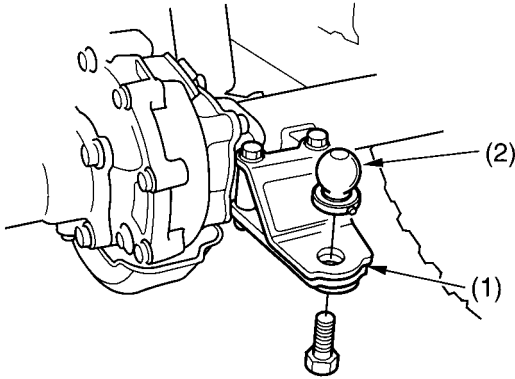

(1) trailer hitch

(2) ball

The trailer hitch (1) is located on the rear axle housing. To use the hitch, you'll need a proper size ball (2) as specified by the trailer manufacturer.

To attach the ball and properly hook up a trailer, follow the trailer manufacturer's instructions. For load limits and operational guidelines, see page 46.

Controls & Features

Accessory Socket

LEFT FRONT FENDER

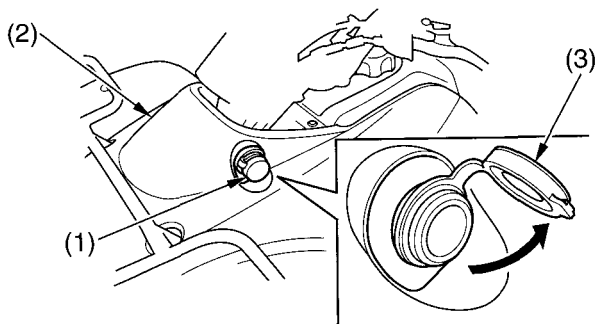

(1) accessory socket
(2) front fender

(3) cap

The accessory socket (1) is attached to the left side of the front fender (2). You can use the accessory socket to power a trouble light, spotlight, CB radio, or cell phone, etc.

NOTICE

Do not plug in any heat-generating accessory such as an automobile cigarette lighter because it can damage the socket.

To use the accessory socket, turn the ignition switch ON (1) to start the engine. Then turn the headlights OFF, and open the accessory socket cap (3).

Controls & Features

Be sure the engine is on and the headlights are turned off before using the accessory socket, otherwise you may drain the battery.

The accessory socket's rated capacity is DC 12V, 120 Watts (10A) or less.

If you exceed this limit, you may blow a fuse. See *If a Fuse Blows*, page 179 .

When you are done using an accessory, unplug it, and cover the socket with the cap.

Be careful not to flood this accessory socket when washing your ATV.

Before Riding

Before each ride, you need to make sure you and your Honda are both ready to ride. To help get you prepared, this section discusses how to evaluate your riding readiness, what items you should check on your ATV, and adjustments to make for your comfort, convenience, or safety. This section also includes important information about loading.

Are You Ready to Ride ?	36
Protective Apparel.....	36
Rider Training	38
Age Recommendation	39
No Passengers	39
No Alcohol or Drugs.....	40
Is Your ATV Ready to Ride ?.....	41
Pre-ride Inspection	41
Load Limits & Guideline	44
Loading	44
Load Limits	45
Loading Guidelines	46
Accessories & Modifications	47
Accessories.....	47
Modifications	48

Are You Ready to Ride?

Before you ride your ATV for the first time, we urge you to:

- Read this owner's manual and the labels on your ATV carefully.
- Make sure you understand all the safety messages.
- Know how to operate all the controls.

Before each ride, be sure:

- You feel well and are in good physical and mental condition.
- You are wearing an approved motorcycle helmet (with chin strap tightened securely), eye protection, and other protective clothing.
- You don't have any alcohol or drugs in your system.

Protective Apparel

For your safety, we strongly recommend that you always wear an approved motorcycle helmet, eye protection, boots, gloves, long pants, and a long-sleeved shirt or jacket whenever you ride.

Although complete protection is not possible, wearing proper gear can reduce the chance of injury when you ride.

Following are suggestions to help you choose the proper gear.

Helmets and Eye Protection

Your helmet is your most important piece of riding gear because it offers the best protection against head injuries. A helmet should fit your head comfortably and securely.

Are You Ready to Ride?

An open-face helmet offers some protection, but a full-face helmet offers more. Regardless of the style, look for a DOT (Department of Transportation) sticker in any helmet you buy (USA only). Always wear a face shield or goggles to protect your eyes and help your vision.

⚠ WARNING

Operating this ATV without wearing an approved motorcycle helmet, eye protection, and protective clothing could increase your chances of severe injury or death in the event of an accident.

Always wear an approved motorcycle helmet that fits properly and wear eye protection (goggles or face shield), gloves, boots, long-sleeved shirt or jacket and long pants.

Additional Riding Gear

In addition to a helmet and eye protection, we also recommend:

- Sturdy off-road motorcycle boots to help protect your feet, ankles, and lower legs.
- Off-road motorcycle gloves to help protect your hands.
- Riding pants with knee and hip pads, a riding jersey with padded elbows, and a chest/shoulder protector.

Are You Ready to Ride?

Rider Training

Developing your riding skills is an on-going process. Even if you have ridden other ATVs, take time to become familiar with how this ATV works and handles. Practice riding the ATV in a safe area to build your skills. Do not ride in rough terrain until you get accustomed to the ATV's controls, and feel comfortable with its size and weight.

We urge all riders to take a certified course approved by the ATV Safety Institute (ASI). For information about the ASI training course nearest you, call the national toll-free number; (800) 887-2887 (USA only).

Other riding tips can be found in the *Tips & Practice Guide for the ATV Rider* booklet that came with your ATV (USA only).

WARNING

Operating this ATV without proper instruction could increase your risk of an accident which could lead to serious injury or death.

Beginning and inexperienced operators should complete the certified training course offered by Honda. They should then regularly practice the skills learned in the course and the operating techniques described in the owner's manual.

Are You Ready to Ride?

Age Recommendation

The minimum recommended age for this ATV model is 16. For safety, never let children under 16 years old operate this vehicle.

WARNING

A child using an ATV that is not recommended for their age could lose vehicle control while riding, resulting in severe injury or death.

A child under 16 should never operate an ATV with engine size greater than 90cc.

No Passengers

This ATV is designed as an operator-only vehicle. The long seat is designed to allow the rider to change body position, not for carrying a passenger. Never let a passenger ride on the seat or on the front or rear cargo racks.

WARNING

Carrying a passenger on this ATV greatly reduces your ability to balance and control this ATV and could cause a crash and you or your passenger could be injured or killed.

Never carry a passenger on this ATV.

Are You Ready to Ride?

No Alcohol or Drugs

Alcohol, drugs and ATVs don't mix. Even a small amount of alcohol can impair your ability to operate an ATV safely. Likewise, drugs — even if prescribed by a physician — can be dangerous while operating an ATV. Consult your doctor to be sure it is safe to operate a vehicle after taking medication.

WARNING

Operating this ATV after consuming alcohol or drugs can seriously affect your judgement, cause you to react more slowly, affect your balance and perception, and result in serious injury or death.

Never consume alcohol or drugs before or while operating this ATV.

Is Your ATV Ready to Ride?

Before each ride, it's important to inspect your ATV and make sure any problem you find is corrected. A pre-ride inspection is a must, not only for safety, but because having a breakdown, or even a flat tire, can be a major inconvenience.

If your ATV has overturned or been involved in a collision, do not ride the vehicle until it has been inspected by your Honda dealer. There may be damage or other problems you cannot see.

WARNING

Improperly maintaining this ATV or failing to correct a problem before riding can cause a crash in which you can be seriously hurt or killed.

Always perform a pre-ride inspection before every ride and correct any problems.

Pre-ride Inspection

Check the following items before you get on the ATV:

Engine Oil

Check the level and add oil if needed (page 103).

Check for leaks.

Fuel

Check the level and add fuel (page 98) if needed. Also make sure the fuel fill cap is securely fastened.

Check for leaks.

Is Your ATV Ready to Ride?

<i>Tires</i>	Use a gauge to check the air pressure. Adjust if needed. Also look for signs of damage or excessive wear (page 142).
<i>Driveshaft Boots</i>	Check for damage (page 148).
<i>Nuts & Bolts</i>	Check the wheels to see that the axle nuts are tightened. Use a wrench to make sure all accessible nuts, bolts, and fasteners are tight.
<i>Underbody & Exhaust System</i>	Check for, and remove, any dirt, vegetation or other debris that could be a fire hazard or interfere with the proper operation of the vehicle.
<i>Air Cleaner Housing Drain Tube</i>	Check for deposits in the drain tube. If necessary, clean the tube (page 115) and check the air cleaner housing.
<i>Leaks, Loose Parts</i>	Walk around your ATV and look for anything that appears unusual, such as a leak or loose cable.
<i>Cable</i>	Check the cable housings for wear. Check the fittings for looseness. Replace or tighten as needed.

Is Your ATV Ready to Ride?

If you are carrying cargo, also check the following:

Loading Limits Make sure you do not exceed the load limits (page 46).

Cargo Check that all cargo is secure.

Check these items after you get on the ATV:

Throttle Check the freeplay and adjust if needed. Press the throttle to make sure it moves smoothly without sticking, and snaps shut automatically when it is released, in all steering positions (page 116).

Brakes Squeeze the front and rear brake levers and step on the rear brake pedal to check that the controls operate normally. Check for proper freeplay (page 129 , 133 , 135). Make sure there is no brake fluid leakage.

*Headlight and
Headlight Dimmer
Switch* Check for proper function (page 26).

*Engine Stop
Switch* Check for proper function (page 25).

Steering Check that the wheels turn properly as you steer the handlebar.

Remember, be sure to take care of any problem you find, or have your Honda dealer correct it before you ride.

Load Limits & Guidelines

Your Honda was designed as a rider-only ATV. It was not designed to carry a passenger. It can carry cargo on the cargo racks, however, carrying cargo anywhere else or carrying a passenger could interfere with your balance and control of the ATV.

In addition, exceeding the weight limits or carrying an unbalanced load can seriously affect your ATV's handling, braking, and stability. Adding accessories or making modifications that change this ATV's design and performance can also make it unsafe. Also, the weight of any accessories will reduce the maximum load the ATV can carry.

More specific information on load limits, accessories, and modifications follows.

Loading

How much weight you put on your ATV, and how you load it, are important to your safety. If you decide to carry cargo, you should be aware of the following information.

WARNING

Overloading, improper loading, or carrying a passenger can cause a crash and you can be seriously hurt or killed.

Follow all load limits and other loading guidelines in this manual.

Load Limits & Guidelines

Load Limits

Following are the load limits for your ATV:

There are limits to how much weight can be carried on your ATV and be pulled in a trailer.

The following load limits apply to standard equipment only. Modifying your ATV, using non-standard equipment, or riding on terrain that is not flat and smooth could further reduce these limits.

maximum weight capacity (includes the weight of the rider, all cargo, and accessories.)	485 lbs (220 kg) maximum
front cargo rack weight limit	= 66 lbs (30 kg) maximum
rear cargo rack weight limit	= 133 lbs (60 kg) maximum
tow weight limit (Combined weight of the trailer and all cargo in the trailer)	= 850 lbs {385 kg} (3776 N) maximum
tongue weight (Weight on the trailer tongue)	= 30 lbs {14 kg} (137 N) recommended
tongue and rear cargo weight (Combined weight on the trailer tongue and on the rear cargo rack)	= 133 lbs (60 kg) maximum

Tongue weight can be measured with an ordinary bathroom scale. Place the scale under the tongue, using either a tongue jack or other support to keep the trailer level.

The weight of added accessories will reduce the maximum cargo weight you can carry.

Load Limits & Guidelines

Loading Guidelines

Carrying cargo or pulling a trailer will affect how your ATV handles and greatly reduce its ability in accelerating, braking and making turns and other maneuvers.

Be sure to observe the weight limits and follow these guidelines:

- Check that the tires are properly inflated.
- Do not place cargo anywhere on the ATV other than on the front and rear racks. Otherwise, operating stability may be adversely affected.
- Never ride with a passenger on the front or rear cargo racks. The ATV is not designed to carry a passenger.
- Use the trailer hitch to tow another vehicle or trailer. Do not tow by tying a rope or cable to the rear rack.
- Load cargo on the rear rack as far forward as possible. Make sure cargo on the front rack does not interfere with handlebar movement.
- Do not allow cargo to extend beyond the edges of either the front or rear racks.
- Make sure all cargo is secured before riding.
- Balance cargo weight evenly on both sides.
- Never exceed the maximum weight limit.
- When towing a trailer, take care to maintain balance and stability. Distribute cargo between the front and rear of the trailer to obtain the recommended tongue weight.
- Allow extra room for starting, stopping and turning whenever you carry cargo or pull a trailer.
- Avoid riding on steep slopes when carrying cargo or pulling a trailer.
- Never cross a slope when towing a trailer.

Accessories & Modifications

Modifying your ATV or using non-Honda accessories can make your ATV unsafe.

Before you consider making any modifications or adding an accessory, be sure to read the following information.

⚠ WARNING

Improper accessories or modifications can cause a crash in which you can be seriously hurt or killed.

Follow all instructions in this owner's manual regarding accessories and modifications.

Accessories

We strongly recommend that you use only genuine Honda accessories that have been specifically designed and tested for your ATV. Because Honda cannot test all other accessories, you must be personally responsible for proper selection, installation, and use of non-Honda accessories.

Check with your Honda dealer for assistance and always follow these guidelines:

- Make sure the accessory does not obscure any lights, reduce ground clearance, limit suspension travel or steering travel, or interfere with operating any controls.
- Make sure the accessory does not interfere with your ability to shift body position on the seat or operate hand and foot controls.
- Do not add any electrical equipment that will exceed the vehicle's electrical system capacity (page 191). A blown fuse can cause a loss of lights or engine power (page 179).

Accessories & Modifications

Modifications

We strongly advise you not to remove any original equipment or modify your ATV in any way that would change its design or operation. Such changes could seriously impair your ATV's handling, stability, and braking, making it unsafe to ride.

We also advise you not to make any modifications or remove any equipment (such as the USDA qualified spark arrester or emission control system components) that would make your ATV illegal in your area.

Removing or modifying your lights, exhaust system, emission control system, or other equipment can also make your ATV illegal.

Basic Operation & Riding

This section gives basic riding instructions, including how to start and stop your engine, and how to use the throttle and brakes. It also provides important information on riding with cargo.

To protect your new engine and enjoy optimum performance and service life, refer to Break-in Guidelines (page 192).

For information about carburetor adjustment for riding at high altitude, see page 189.

Safe Riding Precautions.....	51
Off-Road Use Only.....	51
Keeps Hands and Feet on Controls	52
Control Speed.....	53
Use Care on Unfamiliar or Rough Terrain.....	54
Do Not Perform Stunts.....	55
Starting & Stopping the Engine	56
Preparation	56
Starting Procedure.....	57
Flooded Engine	59
How to Stop the Engine	59
Using the Recoil Starter	60
Shifting Gears	61
Riding in Reverse.....	63

(cont'd)

Basic Operation & Riding

Braking.....	65
Riding Your ATV	67
Making Turns.....	67
Skidding or Sliding	69
Riding Up Hills	70
Riding Down Hills	74
Crossing or Turning on Hills or Slopes.....	75
Riding Over Obstacles	77
Riding Through Water	78
Parking	79

Safe Riding Precautions

Before riding your ATV for the first time, please review the *ATV Safety* section beginning on page 1, and the *Before Riding* section beginning on page 35.

Even if you have ridden other ATVs, take time to become familiar with how this ATV works and handles. Practice in a safe area until you build your skills and get accustomed to the ATV's size and weight.

Off-Road Use Only

Your ATV and its tires are designed and manufactured for off-road use only, not for pavement. Riding on pavement can affect handling and control. You should not ride your ATV on pavement.

WARNING

Operating this ATV on paved surfaces may seriously affect handling and control of the ATV, and may cause the vehicle to go out of control.

Never operate the ATV on any paved surfaces, including sidewalks, driveways, parking lots and streets.

When riding off-road, also remember to always obey local off-road riding laws and regulations. Obtain permission to ride on private property. Avoid posted areas and obey “no trespassing” signs.

Safe Riding Precautions

You should never ride your ATV on public streets, roads or highways, even if they are not paved. Drivers of street vehicles may have difficulty seeing and avoiding you, which could lead to a collision. In many states it is illegal to operate ATVs on public streets, roads and highways.

WARNING

Operating this ATV on public streets, roads or highways could cause you to collide with another vehicle.

Never operate this ATV on any public street, road or highway, even a dirt or gravel one.

Keep Hands and Feet on Controls

Always keep both hands on the handlebars and both feet on the footpegs when riding your ATV. This is important to maintain your balance and to control the vehicle. Removing even one hand from the handlebars or one foot from the footpegs can reduce your ability to control the ATV or could cause you to lose your balance and fall off the ATV.

WARNING

Removing hands from handlebars or feet from footpegs during operation can reduce your ability to control the ATV or could cause you to lose your balance and fall off of the ATV.

Always keep both hands on the handlebars and both feet on the footpegs of your ATV during operation.

Safe Riding Precautions

Control Speed

Riding at excessive speed increases the chance of an accident. In choosing a proper speed, you need to consider the capability of your vehicle, the terrain, visibility and other operating conditions, plus your own skills and experience.

WARNING

Operating this ATV at excessive speeds increases your chances of losing control of the ATV, which can result in an accident.

Always go at a speed that is proper for your vehicle, the terrain, visibility and other operating conditions, and your experience.

Safe Riding Precautions

Use Care on Unfamiliar or Rough Terrain

Before riding in a new area, always check the terrain thoroughly. Don't ride fast on unfamiliar terrain or when visibility is limited. (It's sometimes difficult to see obstructions like hidden rocks, bumps, or holes in time to react.)

WARNING

Failure to use extra care when operating this ATV on unfamiliar terrain could result in the ATV overturning or going out of control.

Go slowly and be extra careful when operating on unfamiliar terrain. Always be alert to changing terrain conditions when operating the ATV.