

**2008
Honda TRX400EX
SPORTRAX 400EX
OWNER'S MANUAL**

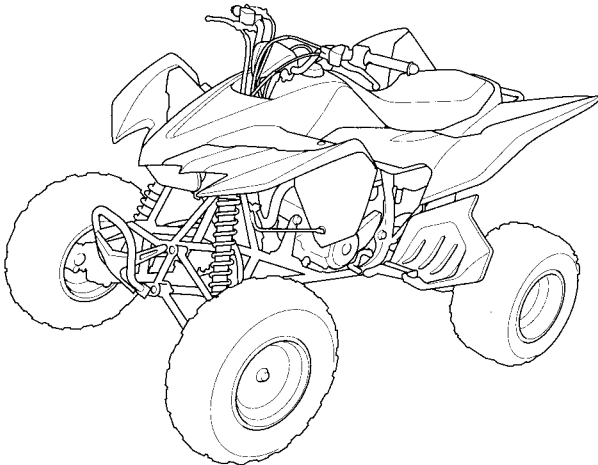

FOR OFF-ROAD USE ONLY

This vehicle is designed and manufactured for off-road use only.
USA only:

It conforms to US EPA Noise Emission regulations, but does not conform to Federal Motor Vehicle Safety Standards or US EPA On Highway Exhaust Emission regulations, and operation on public streets, roads, or highways is illegal. The vehicle is equipped with a USDA qualified spark arrester. Obey local laws and regulations.

It conforms to US EPA, California, and Environment Canada exhaust emission regulations for ATVs.

Introduction

Congratulations on choosing your Honda ATV.

When you own a Honda, you're part of a worldwide family of satisfied customers — people who appreciate Honda's reputation for building quality into every product.

Your Honda was designed as a recreational ATV for off-road use by one rider only.

Before riding, take time to get acquainted with your ATV and how it works. To protect your investment, we urge you to take responsibility for keeping your ATV well maintained. Scheduled service is a must, of course. But it's just as important to observe the break-in guidelines, and perform all pre-ride and other periodic checks detailed in this manual.

We also recommend that you read this owner's manual before you ride. It's full of facts, instructions, safety information, and helpful tips. To make it easy to use, the manual contains a detailed list of topics at the beginning of each section, and both an in-depth table of contents and an index at the back of the book.

As you read this manual, you will find information that is preceded by a **NOTICE** symbol. This information is intended to help you avoid damage to your Honda, other property, or the environment.

Read the Warranties Booklet (page 203) thoroughly so you understand the coverages that protect your new Honda and are aware of your rights and responsibilities.

Whenever you ride, tread lightly. By staying on established trails and riding only in approved areas, you help protect the environment and keep off-road riding areas open for the future.

Introduction

If you have any questions, or if you ever need special service or repairs, remember that your Honda dealer knows your ATV best and is dedicated to your complete satisfaction.

Please report any change of address or ownership to your Honda dealer so we will be able to contact you concerning important production information.

You may also want to visit our website at www.honda.com.

Happy riding!

California Proposition 65 Warning

WARNING: This product contains or emits chemicals known to the State of California to cause cancer and birth defects or other reproductive harm.

A Few Words About Safety

Your safety, and the safety of others, is very important. And operating this ATV safely is an important responsibility.

To help you make informed decisions about safety, we have provided operating procedures and other information on labels and in this manual. This information alerts you to potential hazards that could hurt you or others.

Of course, it is not practical or possible to warn you about all hazards associated with operating or maintaining an ATV. You must use your own good judgment.

You will find important safety information in a variety of forms, including:

Safety Labels — on the ATV.

Safety Messages — preceded by a safety alert symbol  and one of three signal words: **DANGER**, **WARNING**, or **CAUTION**.

A Few Words About Safety

These signal words mean:

 **DANGER**

You **WILL** be **KILLED** or **SERIOUSLY HURT** if you don't follow instructions.

 **WARNING**

You **CAN** be **KILLED** or **SERIOUSLY HURT** if you don't follow instructions.

 **CAUTION**

You **CAN** be **HURT** if you don't follow instructions.

Safety Headings — such as Important Safety Reminders or Important Safety Precautions.

Safety Section — such as ATV Safety.

Instructions — how to use this ATV correctly and safely.

This entire manual is filled with important safety information — please read it carefully.

Contents

These pages give an overview of the contents of your owner's manual. The first page of each section lists the topics covered in that section.

ATV Safety	1
Important safety information you should know, plus a look at the safety-related labels on your ATV.	
Indicators & Controls	9
The location and function of indicators and controls on your ATV and operating instructions for various controls and features.	
Before Riding.....	25
The importance of wearing a helmet and other protective gear, how to make sure you and your ATV are ready to ride, and important information about loading.	
Basic Operation & Riding	39
How to start and stop the engine, shift gears, and brake. Also, riding precautions.	

Contents

Servicing Your Honda	71
Why your ATV needs regular maintenance, what you need to know before servicing your Honda, an owner maintenance schedule, and instructions for specific maintenance and adjustment items.	
Tips	157
How to store and transport your ATV and how to be an environmentally-responsible rider.	
Taking Care of the Unexpected	167
What to do if you have a flat tire, your engine won't start, etc.	
Technical Information	183
ID numbers, technical specifications, and other technical facts.	
Consumer Information	199
Information on warranties, emission controls, how to get Honda service manuals.	
Table of Contents	208
Sequential listing of topics in this owner's manual.	
Index	214
Quick Reference	
Handy facts about fuel, engine oil, tire sizes, and air pressures.	

ATV Safety

This section presents some of the most important information and recommendations to help you ride your ATV safely. Please take a few moments to read these pages. This section also includes information about the location of safety labels on your ATV.

Important Safety Information	2
Safety Labels.....	5

Important Safety Information

Your ATV can provide many years of service and pleasure — if you take responsibility for your own safety and understand the challenges you can meet while riding.

There is much that you can do to protect yourself when you ride. You'll find many helpful recommendations throughout this manual. The following are a few that we consider most important.

Follow the Age Recommendation

The minimum recommended age for this ATV model is 16. Children under age 16 should never operate this vehicle.

Always Wear a Helmet

It's a proven fact: helmets significantly reduce the number and severity of head injuries. So always wear an approved motorcycle helmet. We also recommend that you wear eye protection, sturdy boots, gloves, and other protective gear (page 26).

Never Carry a Passenger

Your ATV is designed for one person only. There are no handholds, footrests, or seat for a second person — so never carry a passenger. A passenger could interfere with your ability to move around to maintain your balance and control of the ATV.

Important Safety Information

Ride Off-Road Only

Your ATV is designed and manufactured for off-road use only. The tires are not made for pavement, and the ATV does not have turn signals and other features required for use on public roads. If you need to cross a paved or public road, get off and walk your ATV across.

Take Time to Learn & Practice

Even if you have ridden other ATVs, take time to become familiar with how this ATV works and handles. Practice in a safe area until you build your skills and get accustomed to the ATV's size and weight.

Because many accidents involve inexperienced or untrained riders, we urge all riders to take a training course approved by the ATV Safety Institute (ASI). See page 28.

Contact an authorized ATV dealer or call 1-800-887-2887 (USA only) to find out about the training courses nearest you.

Be Alert for Off-Road Hazards

The terrain can present a variety of challenges when you ride off-road. Continually "read" the terrain for unexpected turns, drop-offs, rocks, ruts, and other hazards. Always keep your speed low enough to allow time to see and react to hazards.

Important Safety Information

Ride within Your Limits

Pushing limits is another major cause of ATV accidents. Never ride beyond your personal abilities or faster than conditions warrant. Remember that alcohol, drugs, fatigue, and inattention can significantly reduce your ability to make good judgments and ride safely.

Don't Drink and Ride

Alcohol and riding don't mix. Even one drink can reduce your ability to respond to changing conditions, and your reaction time gets worse with every additional drink. So don't drink and ride, and don't let your friends drink and ride either.

Keep Your Honda in Safe Condition

It's important to keep your ATV properly maintained and in safe riding condition. Having a breakdown can be difficult, especially if you are stranded off-road far from your base. To help avoid problems, inspect your ATV before every ride and perform all recommended maintenance.

Safety Labels

Your ATV comes with a hang tag and several labels containing important safety information. Anyone who rides the vehicle should read and understand this information before riding.

The labels should be considered permanent parts of the vehicle. If a label comes off or becomes hard to read, contact your Honda dealer for replacements.

Safety Labels

USA only

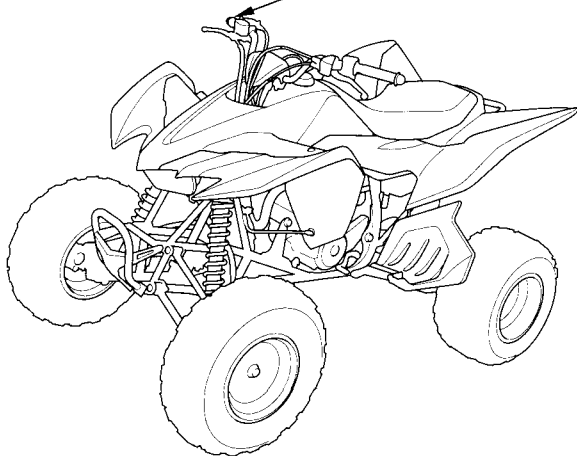
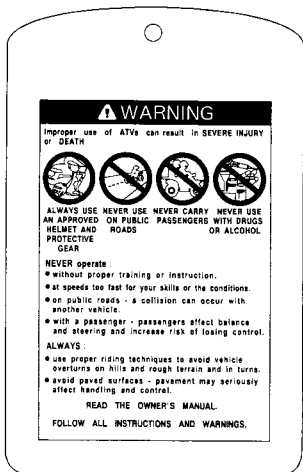

Safety Labels

WARNING

Improper tire pressure or overloading can cause loss of control.

Loss of control can result in severe injury or death.

● Cold tire pressure :

Front : 27.5kPa 0.275kgf / cm² 4.0psi

Rear : 27.5kPa 0.275kgf / cm² 4.0psi

● Maximum weight capacity : 110kg (243lbs)

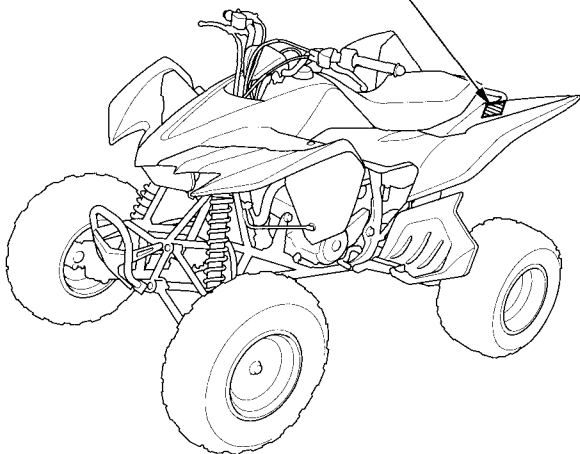

Safety Labels

WARNING

UNDER 16

Operating this ATV if you are under the age of 16 increases your chance of severe injury or death.

NEVER operate this ATV if you are under age 16.

WARNING

NEVER ride as a passenger. Passengers can cause a loss of control, resulting in **SEVERE INJURY** or **DEATH**.

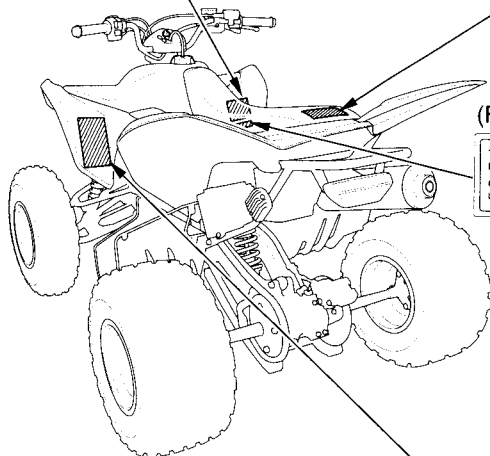

(For Canada)

THIS VEHICLE IS AN ALL-TERRAIN VEHICLE AND IS NOT INTENDED FOR USE ON PUBLIC HIGHWAYS.
 CE VÉHICULE EST UN VÉHICULE TOUT TERRAIN ET DONT L'USAGE N'EST PAS DESTINÉ AUX VOIES PUBLIQUES.

WARNING

Improper use of ATVs can result in **SEVERE INJURY** or **DEATH**



ALWAYS USE **NEVER USE** **NEVER CARRY** **NEVER USE**
AN APPROVED **ON PUBLIC** **PASSENGERS WITH DRUGS**
HELMET AND **ROADS** **OR ALCOHOL.**
PROTECTIVE
GEAR

NEVER operate:

- without proper training or instruction.
- at speeds too fast for your skills or the conditions.
- on public roads - a collision can occur with another vehicle.
- with a passenger - passengers affect balance and steering and increase risk of losing control.

ALWAYS:

- use proper riding techniques to avoid vehicle overturns on hills and rough terrain and in turns.
- avoid paved surfaces - pavement may seriously affect handling and control!

READ THE OWNER'S MANUAL.

FOLLOW ALL INSTRUCTIONS AND WARNINGS.

Indicators & Controls

This section shows the location of all indicators and controls you would normally use before or while riding your ATV.

The items listed on this page are described in this section. Instructions for other components are presented in other sections of this manual where they will be most useful.

Operation Component Locations	11
Indicators.....	14
Reverse and Neutral Indicators	14

Indicators & Controls

Controls & Features	15
Fuel Valve	15
Choke Lever	16
Ignition Switch	17
Start Button	18
Engine Stop Switch	18
Headlight Switch	19
Headlight Dimmer Switch	19
Throttle Lever	20
Clutch Lever/Parking Brake Lever	20
Reverse Assist Knob	21
Front Brake Lever	22
Rear Brake Pedal	22
Parking Brake	23
Flag Pole Bracket	24

Operation Component Locations

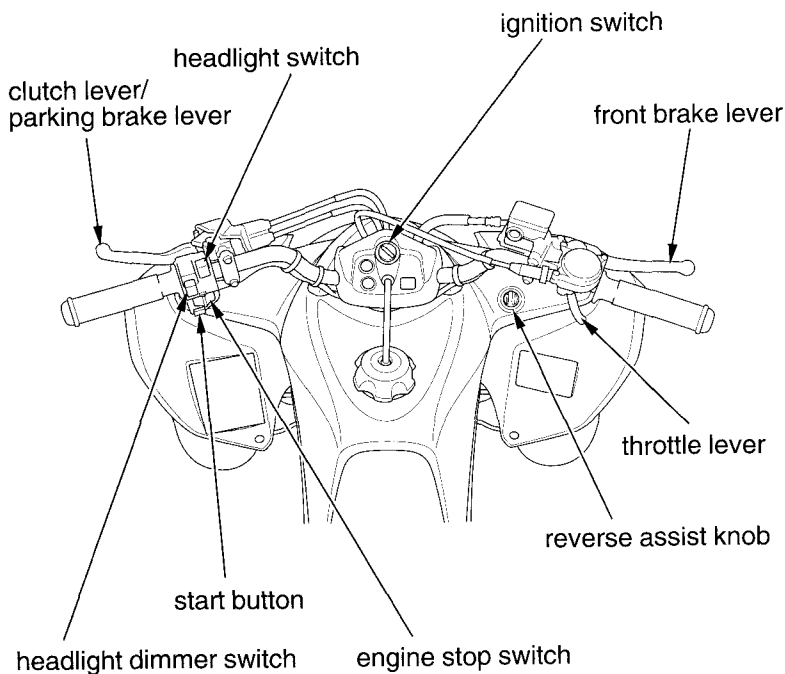

Operation Component Locations

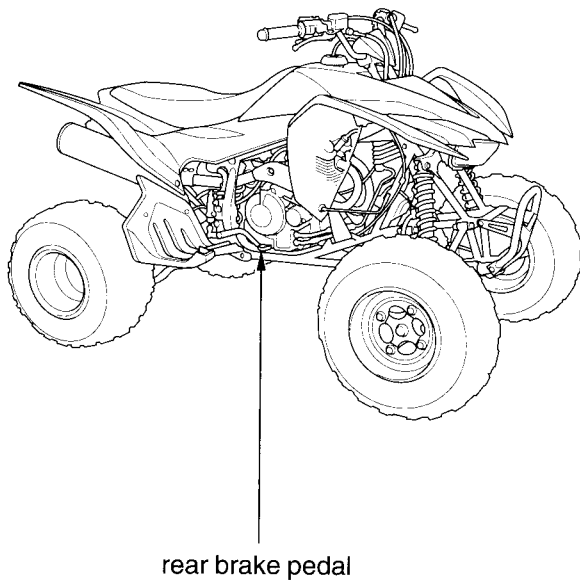

Operation Component Locations

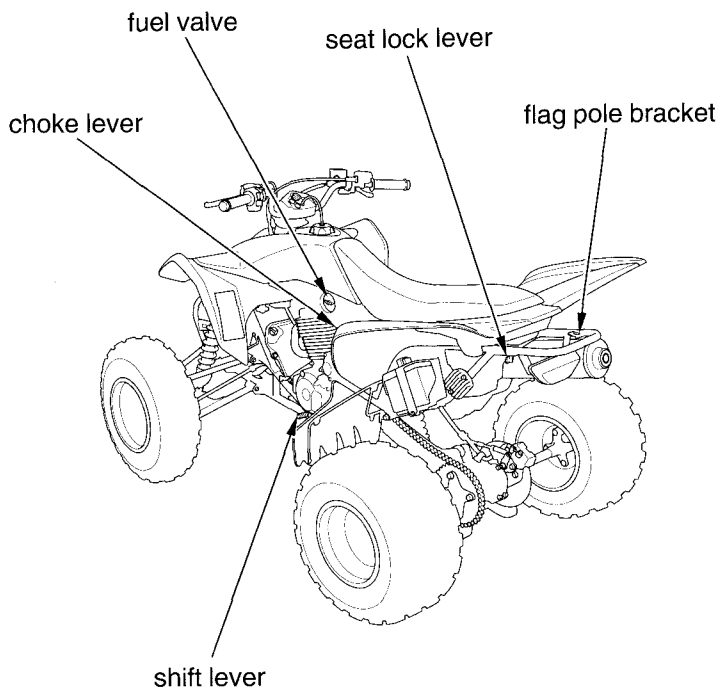

Indicators

Reverse and Neutral Indicators

The reverse indicator (1) and the neutral indicator (2) are located on the handle cover.

The reverse indicator will light when the transmission is in reverse and the ignition switch is ON (I).

The neutral indicator will light when the transmission is in neutral and the ignition switch is ON (I).

If one of these indicators does not come on when it should, have your Honda dealer check for burned-out bulbs or other problems.

CENTER OF HANDLEBAR

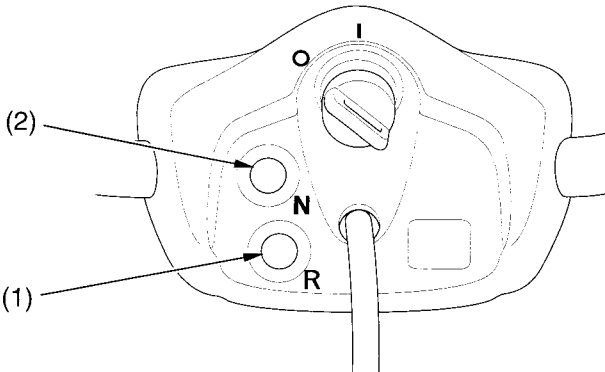

- (1) reverse indicator
- (2) neutral indicator

Controls & Features

Fuel Valve

LEFT SIDE

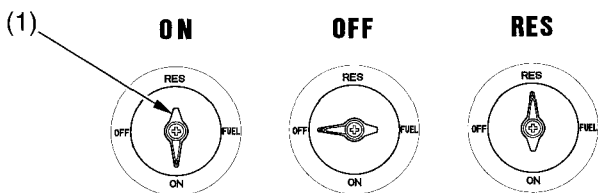

(1) fuel valve

The manual fuel valve (1) is located on the left side of the fuel tank.

The three-way fuel valve is used to control the flow of fuel from the fuel tank to the carburetor.

ON—normal position for riding.

OFF—for parking, storing, or transportation.

RES—for extra fuel to get to a gas supply for refueling.

Reserve Fuel

Remember to check that the fuel valve is in the ON position each time you refuel. If the fuel valve is left in the RES position, you may run out of fuel with no reserve.

For complete information about fueling your ATV, see page 87 .

Controls & Features

Choke Lever

LEFT SIDE

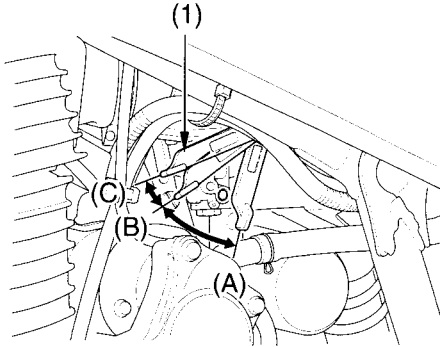

(1) choke lever

(A) fully OFF

(B) halfway position

(C) fully ON

The choke lever (1) may be used when starting the engine. See page 46 .

Controls & Features

Ignition Switch

The ignition switch (1) is used for starting and stopping the engine (page 46). Insert the key and turn it to the right for the ON (I) position.

Key Position	Function
ON (I)	Electrical circuits on.
OFF (O)	No electrical circuits function.

CENTER OF HANDLEBAR

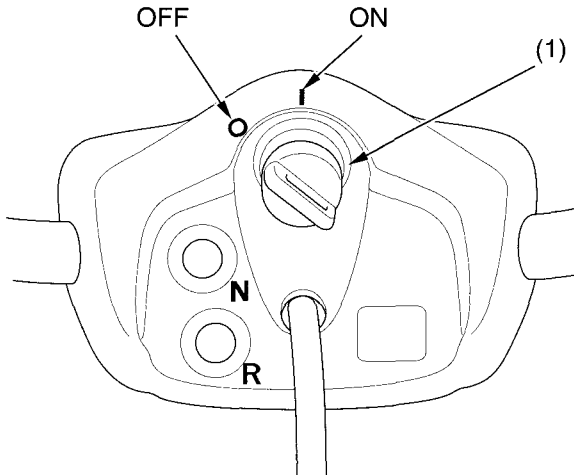

(1) ignition switch

I ON
O OFF

Controls & Features

Start Button



LEFT HANDLEBAR

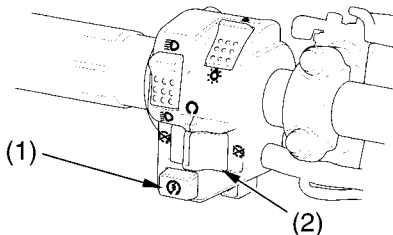

- (1) start button
- (2) engine stop switch

- Ⓢ START
- ⊗ OFF
- RUN

The start button (1) is used for starting the engine. Pushing the button in starts the engine. See *Starting Procedure*, page 48.

When the start button is pushed, the starter motor will crank the engine. The starter motor will operate even if the engine stop switch is in the OFF (⊗) position when the start button is pushed.

Engine Stop Switch



The engine stop switch (2) is used to stop the engine in an emergency. To operate, slide the switch to the OFF (⊗) position. The switch must be in the RUN (○) position to start the engine, and it should normally remain in the RUN (○) position even when the engine is OFF.

If your ATV is stopped with the ignition switch ON (I) and the engine stop switch OFF (⊗), the battery will discharge. Turn the ignition switch OFF (○) to prevent battery discharge.

Controls & Features

Headlight Switch



LEFT HANDLEBAR

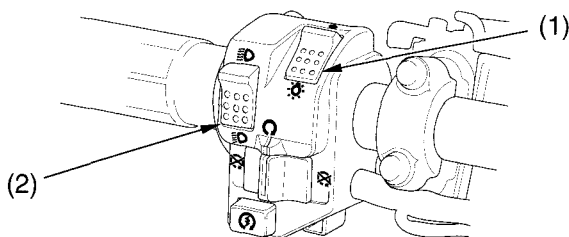

(1) headlight switch

(2) headlight dimmer switch

ON

OFF

HI

LO

The headlight switch (1) is used to turn the headlight ON () or OFF (). To operate, turn the switch to ON () or OFF ().

Headlight Dimmer Switch



The headlight dimmer switch (2) is used to change between the high and low beams of the headlight. To operate, turn the switch to HI () for high beam, LO () for low beam.

Controls & Features

Throttle Lever

RIGHT HANDLEBAR

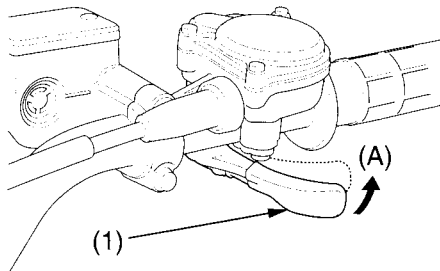

- (1) throttle lever
- (A) to open the throttle

The throttle controls engine rpm (speed). To increase engine rpm, press the throttle lever (1) with your thumb. To reduce engine rpm, release pressure on the throttle lever. The throttle will automatically return to the closed position (engine idle) when you remove your thumb.

Clutch Lever/Parking Brake Lever

The clutch lever/parking brake lever is used to disengage the clutch whenever you shift gears. To operate, pull the clutch lever/parking brake lever in all the way before shifting, then slowly release it after shifting. See *Clutch System*, page 105 .

Controls & Features

Reverse Assist Knob

The reverse assist knob (1), located on the right fender, is used to shift into reverse. To operate, pull in the clutch lever/parking brake lever (2) with your ATV stopped. Leaving your left hand on the clutch lever/parking brake lever, remove your right hand from throttle and turn the reverse assist knob. While turning the reverse assist knob, depress the shift lever (3) to reach the reverse gear (below 1st gear). See *Riding in Reverse* page 54.

LEFT HANDLEBAR

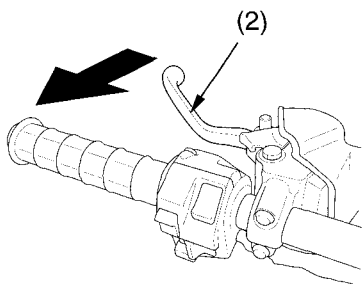

RIGHT SIDE

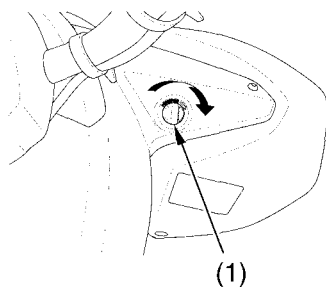

LEFT SIDE

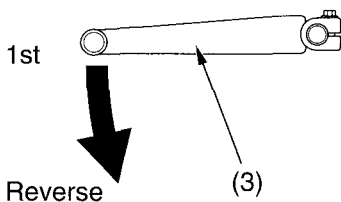

(1) reverse assist knob

(2) clutch lever/parking brake lever

(3) shift lever

Controls & Features

Front Brake Lever

The front brake lever is used to slow or stop your ATV. To operate, pull the lever. For information on braking techniques, see page 56 .

Rear Brake Pedal

The rear brake pedal is used to slow or stop your ATV. To operate, depress the pedal. For information on braking techniques, see page 56 .

Controls & Features

Parking Brake

LEFT HANDLEBAR

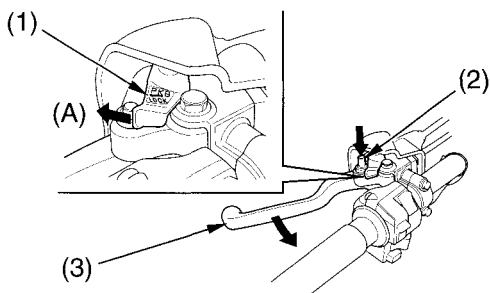

(1) lock lever

(2) parking brake pin

(3) clutch lever/

parking brake lever

(A) to lock

The lock lever (1) and parking brake pin (2) on the clutch lever/parking brake lever (3) allows it to be used as a parking brake. To operate, push down and hold the parking brake pin, squeeze the clutch lever/parking brake lever and then lock it with the lock lever. See *Parking* page 70 .

Controls & Features

Flag Pole Bracket

RIGHT REAR

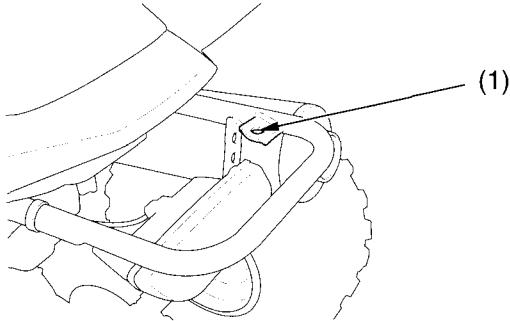

(1) flag pole bracket

Flag poles are optional equipment available from your Honda dealer. To mount a pole in the bracket (1), follow the instructions that come with the flag pole kit.

Flag poles are required in some riding areas. Check local regulations before riding.

Before Riding

Before each ride, you need to make sure you and your Honda are both ready to ride. To help get you prepared, this section discusses how to evaluate your riding readiness, what items you should check on your ATV, and adjustments to make for your comfort, convenience, or safety. This section also includes important information about loading.

Are You Ready to Ride?	26
Protective Apparel.....	26
Rider Training	28
Age Recommendation.....	29
No Passengers	29
No Alcohol or Drugs.....	30
Is Your ATV Ready to Ride?.....	31
Pre-ride Inspection	31
Load Limits & Guideline	34
Loading	34
Load Limits	35
Loading Guidelines	36
Accessories & Modifications	37
Accessories.....	37
Modifications	38

Are You Ready to Ride?

Before you ride your ATV for the first time, we urge you to:

- Read this owner's manual and the labels on your ATV carefully.
- Make sure you understand all the safety messages.
- Know how to operate all the controls.

Before each ride, be sure:

- You feel well and are in good physical and mental condition.
- You are wearing an approved motorcycle helmet (with chin strap tightened securely), eye protection, and other protective clothing.
- You don't have any alcohol or drugs in your system.

Protective Apparel

For your safety, we strongly recommend that you always wear an approved motorcycle helmet, eye protection, boots, gloves, long pants, and a long-sleeved shirt or jacket whenever you ride.

Although complete protection is not possible, wearing proper gear can reduce the chance of injury when you ride.

Following are suggestions to help you choose the proper gear.

Helmets and Eye Protection

Your helmet is your most important piece of riding gear because it offers the best protection against head injuries. A helmet should fit your head comfortably and securely.

Are You Ready to Ride?

An open-face helmet offers some protection, but a full-face helmet offers more. Regardless of the style, look for a DOT (Department of Transportation) sticker on any helmet you buy (USA only). Always wear a face shield or goggles to protect your eyes and help your vision.

⚠ WARNING

Operating this ATV without wearing an approved motorcycle helmet, eye protection, and protective clothing could increase your chances of severe injury or death in the event of an accident.

Always wear an approved motorcycle helmet that fits properly and wear eye protection (goggles or face shield), gloves, boots, long-sleeved shirt or jacket and long pants.

Additional Riding Gear

In addition to a helmet and eye protection, we also recommend:

- Sturdy off-road motorcycle boots to help protect your feet, ankles, and lower legs.
- Off-road motorcycle gloves to help protect your hands.
- Riding pants with knee and hip pads, a riding jersey with padded elbows, and a chest/shoulder protector.

Are You Ready to Ride?

Rider Training

Developing your riding skills is an on-going process. Even if you have ridden other ATVs, take time to become familiar with how this ATV works and handles. Practice riding the ATV in a safe area to build your skills. Do not ride in rough terrain until you get accustomed to the ATV's controls, and feel comfortable with its size and weight.

We urge all riders to take a certified course approved by the ATV Safety Institute (ASI). For information about the ASI training course nearest you, call the national toll-free number; (800) 887-2887 (USA only).

Other riding tips can be found in the *Tips & Practice Guide for the ATV Rider* booklet that came with your ATV (USA only).

WARNING

Operating this ATV without proper instruction could increase your risk of an accident which could lead to serious injury or death.

Beginning and inexperienced operators should complete the certified training course offered by Honda. They should then regularly practice the skills learned in the course and the operating techniques described in the owner's manual.

Are You Ready to Ride?

Age Recommendation

The minimum recommended age for this ATV model is 16. For safety, never let children under 16 years old operate this vehicle.

⚠ WARNING

A child using an ATV that is not recommended for their age could lose vehicle control while riding, resulting in severe injury or death.

A child under 16 should never operate an ATV with engine size greater than 90cc.

No Passengers

This ATV is designed as an operator-only vehicle. The long seat is designed to allow the rider to change body position, not for carrying a passenger. Never let a passenger ride on the seat or on the front or rear cargo racks.

⚠ WARNING

Carrying a passenger on this ATV greatly reduces your ability to balance and control this ATV and could cause a crash and you or your passenger could be injured or killed.

Never carry a passenger on this ATV.

Are You Ready to Ride?

No Alcohol or Drugs

Alcohol, drugs and ATVs don't mix. Even a small amount of alcohol can impair your ability to operate an ATV safely. Likewise, drugs — even if prescribed by a physician — can be dangerous while operating an ATV. Consult your doctor to be sure it is safe to operate a vehicle after taking medication.

WARNING

Operating this ATV after consuming alcohol or drugs can seriously affect your judgement, cause you to react more slowly, affect your balance and perception, and result in serious injury or death.

Never consume alcohol or drugs before or while operating this ATV.

Is Your ATV Ready to Ride?

Before each ride, it's important to inspect your ATV and make sure any problem you find is corrected. A pre-ride inspection is a must, not only for safety, but because having a breakdown, or even a flat tire, can be a major inconvenience.

If your ATV has overturned or been involved in a collision, do not ride the vehicle until it has been inspected by your Honda dealer. There may be damage or other problems you cannot see.

WARNING

Improperly maintaining this ATV or failing to correct a problem before riding can cause a crash in which you can be seriously hurt or killed.

Always perform a pre-ride inspection before every ride and correct any problems.

Pre-ride Inspection

Check the following items before you get on the ATV:

- | | |
|-------------------|---|
| <i>Engine Oil</i> | Check the level and add oil if needed (page 93).
Check for leaks. |
| <i>Fuel</i> | Check the level and add fuel (page 88) if needed. Also make sure the fuel fill cap is securely fastened.
Check for leaks. |

(cont'd)

Is Your ATV Ready to Ride?

<i>Tires</i>	Use a gauge to check the air pressure. Adjust if needed. Also look for signs of damage or excessive wear (page 132).
<i>Drive Chain</i>	Check the condition and slack. Adjust and lubricate if needed. Also check the chain slider for wear and replace if needed (page 139).
<i>Nuts & Bolts</i>	Check the wheels to see that the axle nuts are tightened. Use a wrench to make sure all accessible nuts, bolts, and fasteners are tight.
<i>Underbody & Exhaust System</i>	Check for, and remove, any dirt, vegetation or other debris that could be a fire hazard or interfere with the proper operation of the vehicle.
<i>Air Cleaner Housing Drain Tube</i>	Check for deposits in the drain tube. If necessary, clean the tube (page 101) and check the air cleaner case.
<i>Leaks, Loose Parts</i>	Walk around your ATV and look for anything that appears unusual, such as a leak or loose cable.
<i>Cable</i>	Check the cable housings for wear. Check the fittings for looseness. Replace or tighten as needed.
<i>Lights</i>	Make sure the headlight, brakelight and taillight are working properly.

Is Your ATV Ready to Ride?

Check these items after you get on the ATV:

- | | |
|--|---|
| <i>Throttle</i> | Check the freeplay and adjust if needed. Press the throttle to make sure it moves smoothly without sticking, and snaps shut automatically when it is released, in all steering positions (page 103). |
| <i>Brakes</i> | Squeeze the front brake lever and step on the rear brake pedal to check that the controls operate normally. Check for proper freeplay (page 130). Make sure there is no brake fluid leakage (page 124–125). |
| <i>Clutch Lever/
Parking Brake Lever</i> | Check for smooth operation and adjust if needed (page 105). |
| <i>Reverse Assist Knob</i> | Check the freeplay and adjust if needed (page 109). Make sure the knob operates smoothly without sticking. |
| <i>Headlight and
Headlight Dimmer
Switch</i> | Check for proper function (page 19). |
| <i>Engine Stop Switch</i> | Check for proper function (page 18). |
| <i>Steering</i> | Check that the wheels turn properly as you steer the handlebar. Move the handlebar right and left and check that there is no excessive backlash. |

Remember, be sure to take care of any problem you find, or have your Honda dealer correct it before you ride.

Load Limits & Guidelines

Your Honda was designed as a rider-only ATV. It was not designed to carry a passenger or cargo. A passenger or cargo could interfere with your ability to move around to maintain your balance and control of the ATV.

In addition, exceeding the weight limits or carrying an unbalanced load can seriously affect your ATV's handling, braking and stability. Adding accessories or making modifications that change this ATV's design and performance can also make it unsafe. Also, the weight of any accessories will reduce the maximum load the ATV can carry.

More specific information on load limits, accessories, and modifications follows.

Loading

How much weight you put on your ATV, and how you load it, are important to your safety. If you decide to carry cargo, you should be aware of the following information.

WARNING

Overloading, improper loading, or carrying a passenger can cause a crash and you can be seriously hurt or killed.

Follow all load limits and other loading guidelines in this manual.

Load Limits & Guidelines

Load Limits

Following are the load limits for your ATV:

There are limits to how much weight can be carried on your ATV.

The following load limits apply to standard equipment only. Modifying your ATV, using non-standard equipment, or riding on terrain that is not flat and smooth could further reduce these limits.

maximum weight capacity **243 lbs (110 kg)**
(includes the weight of the rider, all cargo, and accessories.)

The weight of added accessories will reduce the maximum cargo weight you can carry.

Load Limits & Guidelines

Loading Guidelines

As discussed on page 34 , we recommend that you do not carry any cargo on this ATV. However, if you decide to carry cargo, ride at reduced speeds and follow these common-sense guidelines.

Carrying cargo or pulling a trailer will affect how your ATV handles and greatly reduce its ability in accelerating, braking and making turns and other maneuvers.

Be sure to observe the weight limits and follow these guidelines:

- Check that the tires are properly inflated.
- Never ride with a passenger. The ATV is not designed to carry a passenger.
- Do not tow another vehicle.
- Never exceed the maximum weight limit.
- Make sure all cargo is secured before riding.
- Allow extra room for starting, stopping and turning whenever you carry cargo or pull a trailer.
- Avoid riding on steep slopes when carrying cargo or pulling a trailer.
- Never cross a slope when towing a trailer.

Accessories & Modifications

Modifying your ATV or using non-Honda accessories can make your ATV unsafe.

Before you consider making any modifications or adding an accessory, be sure to read the following information.

WARNING

Improper accessories or modifications can cause a crash in which you can be seriously hurt or killed.

Follow all instructions in this owner's manual regarding accessories and modifications.

Accessories

We strongly recommend that you use only Honda Genuine Accessories that have been specifically designed and tested for your ATV. Because Honda cannot test all other accessories, you must be personally responsible for proper selection, installation, and use of non-Honda accessories.

Check with your Honda dealer for assistance and always follow these guidelines:

- Make sure the accessory does not obscure any lights, reduce ground clearance, limit suspension travel or steering travel, or interfere with operating any controls.
- Make sure the accessory does not interfere with your ability to shift body position on the seat or operate hand and foot controls.
- Do not add any electrical equipment that will exceed the vehicle's electrical system capacity (page 188). A blown fuse can cause a loss of lights or engine power (page 176).

Accessories & Modifications

Modifications

We strongly advise you not to remove any original equipment or modify your ATV in any way that would change its design or operation. Such changes could seriously impair your ATV's handling, stability, and braking, making it unsafe to ride.

We also advise you not to make any modifications or remove any equipment (such as the USDA qualified spark arrester or emission control system components) that would make your ATV illegal in your area.

Removing or modifying your lights, exhaust system, emission control system, or other equipment can also make your ATV illegal.

Basic Operation & Riding

This section gives basic riding instructions, including how to start and stop your engine, and how to use the throttle and brakes. and what to do when you're through riding.

To protect your new engine and enjoy optimum performance and service life, refer to Break-in Guidelines (page 190).

For information about carburetor adjustment for riding at high altitude, see page 191.

Safe Riding Precautions	41
Off-Road Use Only	41
Keep Hands and Feet on Controls.....	42
Control Speed.....	43
Use Care on Unfamiliar or Rough Terrain.....	44
Do Not Perform Stunts.....	45
Starting & Stopping the Engine	46
Preparation	47
Starting Procedure	48
Flooded Engine	51
How to Stop the Engine	51
Shifting Gears	52
Riding in Reverse.....	54

(cont'd)

Basic Operation & Riding

Braking.....	56
Riding Your ATV	58
Making Turns.....	58
Skidding or Sliding	60
Riding Up Hills	61
Riding Down Hills	65
Crossing or Turning on Hills or Slopes.....	66
Riding Over Obstacles	68
Riding Through Water	69
Parking	70

Safe Riding Precautions

Before riding your ATV for the first time, please review the *ATV Safety* section beginning on page 1, and the *Before Riding* section beginning on page 25 .

Even if you have ridden other ATVs, take time to become familiar with how this ATV works and handles. Practice in a safe area until you build your skills and get accustomed to the ATV's size and weight.

Off-Road Use Only

Your ATV and its tires are designed and manufactured for off-road use only, not for pavement. Riding on pavement can affect handling and control. You should not ride your ATV on pavement.

WARNING

Operating this ATV on paved surfaces may seriously affect handling and control of the ATV, and may cause the vehicle to go out of control.

Never operate the ATV on any paved surfaces, including sidewalks, driveways, parking lots and streets.

When riding off-road, also remember to always obey local off-road riding laws and regulations. Obtain permission to ride on private property. Avoid posted areas and obey "no trespassing" signs.

(cont'd)

Safe Riding Precautions

You should never ride your ATV on public streets, roads or highways, even if they are not paved. Drivers of street vehicles may have difficulty seeing and avoiding you, which could lead to a collision. In many states it is illegal to operate ATVs on public streets, roads and highways.

WARNING

Operating this ATV on public streets, roads or highways could cause you to collide with another vehicle.

Never operate this ATV on any public street, road or highway, even a dirt or gravel one.

Keep Hands and Feet on Controls

Always keep both hands on the handlebars and both feet on the footpegs when riding your ATV. This is important to maintain your balance and to control the vehicle. Removing even one hand from the handlebars or one foot from the footpegs can reduce your ability to control the ATV or could cause you to lose your balance and fall off the ATV.

WARNING

Removing hands from handlebars or feet from footpegs during operation can reduce your ability to control the ATV or could cause you to lose your balance and fall off of the ATV.

Always keep both hands on the handlebars and both feet on the footpegs of your ATV during operation.

Safe Riding Precautions

Control Speed

Riding at excessive speed increases the chance of an accident. In choosing a proper speed, you need to consider the capability of your vehicle, the terrain, visibility and other operating conditions, plus your own skills and experience.

WARNING

Operating this ATV at excessive speeds increases your chances of losing control of the ATV, which can result in an accident.

Always go at a speed that is proper for your vehicle, the terrain, visibility and other operating conditions, and your experience.

Safe Riding Precautions

Use Care on Unfamiliar or Rough Terrain

Before riding in a new area, always check the terrain thoroughly. Don't ride fast on unfamiliar terrain or when visibility is limited. (It's sometimes difficult to see obstructions like hidden rocks, bumps, or holes in time to react.)

WARNING

Failure to use extra care when operating this ATV on unfamiliar terrain could result in the ATV overturning or going out of control.

Go slowly and be extra careful when operating on unfamiliar terrain. Always be alert to changing terrain conditions when operating the ATV.

Safe Riding Precautions

Never ride past the limit of visibility. Maintain a safe distance between your ATV and other off-road vehicles. Always exercise caution, and use extra care on rough, slippery and loose terrain.

WARNING

Failure to use extra care when operating on excessively rough, slippery or loose terrain could cause loss of traction or vehicle control, which could result in an accident, including an overturn.

Do not operate on excessively rough, slippery or loose terrain until you have learned and practiced the skills necessary to control the ATV on such terrain. Always be especially cautious on these kinds of terrain.

Do Not Perform Stunts

You should always operate your ATV in a safe and reasonable manner. When riding, always keep all four wheels on the ground.

WARNING

Attempting wheelies, jumps, and other stunts increases the chance of an accident, including an overturn.

Never attempt stunts, such as wheelies or jumps. Don't try to show off.

Starting & Stopping the Engine

Always follow the proper starting procedure described below.

For your safety, avoid starting or operating the engine in an enclosed area such as a garage. Your ATV's exhaust contains poisonous carbon monoxide gas which can collect rapidly in an enclosed area and cause illness or death.

Your ATV is equipped with a gear position starter cut-off system. The engine cannot be started if the transmission is in a forward gear—unless the clutch lever/parking brake lever is pulled in. The engine cannot be started if the transmission is in reverse gear.

Starting & Stopping the Engine

Preparation

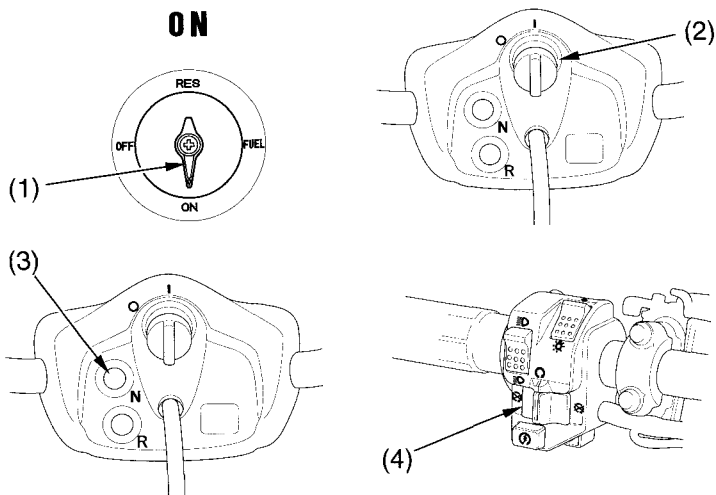

(1) fuel valve
(2) ignition switch

(3) neutral indicator
(4) engine stop switch

1. Before starting, select a level surface and lock the parking brake (page 23).
2. Turn the fuel valve (1) and ignition switch (2) to ON (I).

Confirm the following:

- The transmission is in neutral, and the neutral indicator (3) is ON.
- The engine stop switch (4) is set to RUN (O).

Starting & Stopping the Engine

Starting Procedure

The carburetor is equipped with an accelerator pump. Do not open the throttle when starting the engine. This will flood the engine with excess fuel, resulting in hard starting.

To restart a warm engine, follow the procedure for “*High Air Temperature.*”

The starter motor will operate only when the transmission is in neutral.

Normal Air Temperature 10° – 35°C (50° – 95°F)

LEFT SIDE

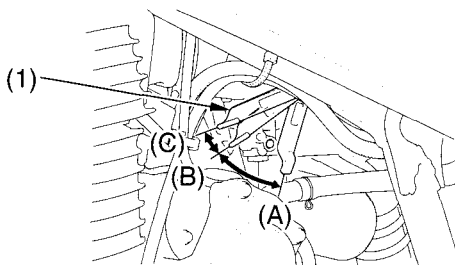

(1) choke lever

(A) fully OFF

(B) halfway position

(C) fully ON

1. If the engine is cold, move the choke lever (1) left to the fully ON (C) position.
 2. With the throttle slightly open, press the start button.
- Pressing the electric start button for more than 5 seconds at a time may cause the starter to overheat and damage the starter. Release the start button for approximately 10 seconds before pressing it again.

Starting & Stopping the Engine

3. Immediately after the engine starts, push the choke lever down to the halfway position (B).
4. Warm up the engine by opening and closing the throttle slightly.
5. After the engine has warmed up, push the choke lever down all the way to fully OFF (A).
6. If idling is unstable, open the throttle slightly.

High Air Temperature 35°C (95°F) or above

LEFT HANDLEBAR

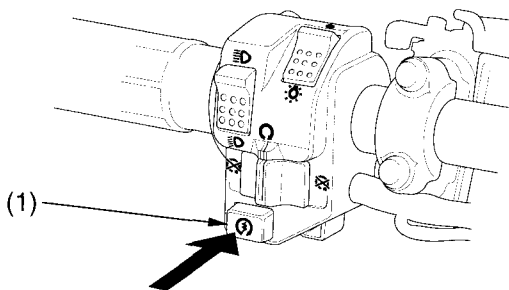

(1) start button

1. Do not use the choke.
2. With the throttle slightly open, press the start button (1).

Starting & Stopping the Engine

Low Air Temperature 10°C (50°F) or below

1. Follow steps 1 – 2 under “*Normal Air Temperature.*”

If the engine does not start after several attempts, operate the start button after opening and closing the throttle lever several times.

2. Warm up the engine by opening and closing the throttle slightly.
3. When the engine begins to run slightly rough, push the choke lever down to the halfway position (B).
4. Continue warming up the engine until it runs smoothly and responds to the throttle, then push the choke lever down all the way to fully OFF (A).
5. If idling is unstable, open the throttle slightly.

NOTICE

Extended use of the choke may impair piston and cylinder wall lubrication and shorten the life of the engine.

Do not race the engine during the warm-up period.

Racing a cold engine wastes fuel and increases engine wear.

Starting & Stopping the Engine

Flooded Engine

If the engine fails to start after repeated attempts, it may be flooded with excess fuel. To clear a flooded engine:

1. Move the engine stop switch to OFF (☒).
2. Move the choke lever to the fully OFF position.
3. Open the throttle fully.
4. Press the start button for 5 seconds.
5. Wait 10 seconds, then turn the engine stop switch to RUN (○).
6. Repeat the “*Normal Air Temperature*” starting procedure, but don’t use the choke.

If the engine still won’t start, refer to *If Your Engine Quits or Won’t Start*, page 170.

How to Stop the Engine

Normal Engine Stop

To stop the engine, make sure the transmission is in neutral by checking that the neutral indicator light is on, then turn the ignition switch OFF (○).

The engine stop switch should normally remain in the RUN (○) position even when the engine is OFF.

If your ATV is stopped with the engine stop switch OFF (☒) and the ignition switch ON (|), the battery will discharge.

Emergency Engine Stop

To stop the engine in an emergency, use the engine stop switch. To operate, slide the switch to the OFF (☒) position.

Shifting Gears

GEAR SHIFTING SEQUENCE

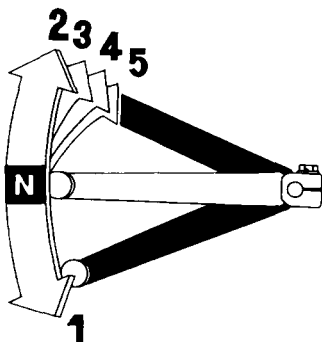

The shift lever is located near the left footpeg. One full stroke of the shift lever shifts the transmission to the next higher or lower gear in the shifting sequence. The shift lever automatically returns to the horizontal position when released.

Your ATV has five forward gears (1, 2, 3, 4 and 5). To shift the transmission, pull in the clutch lever, then operate the shift lever as follows.

To upshift to a higher gear, put the toe of your boot under the shift lever and raise it one full stroke. To downshift, step on the shift lever and depress it one full stroke.

To select reverse, use the reverse assist knob (page 54).

After starting the engine and letting it warm up, follow these procedures:

1. With the transmission in neutral, depress and hold down the rear brake pedal. Release the clutch lever/parking brake lever (page 23).

Shifting Gears

2. While the engine is idling, pull in the clutch lever/parking brake lever and depress the shift lever to shift into 1st gear.
3. Release the brake pedal, gradually release the clutch lever/parking brake lever, and increase engine speed by gradually opening the throttle.
4. When the speed increases, close the throttle, pull in the clutch lever/parking brake lever, shift to 2nd gear by raising the shift lever, and gradually release the clutch lever/parking brake lever while gradually opening the throttle.
5. Repeat this sequence to progressively upshift to 3rd, 4th and 5th (top) gear.
6. To downshift, reverse this sequence. Remember to close the throttle each time you shift to the next lower gear.

Learning when to shift gears comes with experience. Keep the following tips in mind:

- As a general rule, shift while moving in a straight line.
- Close the throttle and pull the clutch lever/parking brake lever in completely before shifting. Improper shifting may damage the engine, transmission, and drive train.
- Upshift to a higher gear or reduce throttle before engine rpm (speed) gets too high. Learn the relationship between engine sound and the normal shifting points.
- Downshift to a lower gear before you feel the engine laboring (lugging) at low rpm.
- Avoid downshifting to help slow your ATV when engine rpm is high. Downshifting when engine speed is near its allowable maximum may over-rev the engine and possibly cause damage.
- To prevent transmission damage, do not coast or tow the ATV for long distances with the engine off.

Recommended Shift Points

Ride in the highest gear that lets the engine run and accelerate smoothly. This will give you good fuel economy and effective emissions control.

Riding in Reverse

If you need to ride in reverse, make sure the area behind you is clear and your ATV has a reverse gear rev limiter that assures low operating speed while backing up.

⚠ WARNING

Improperly operating in reverse could cause you to hit an obstacle or person behind you, resulting in serious injury.

Make sure there are no obstacles or people behind you before selecting reverse gear. When it is safe to proceed, go slowly.

1. Bring the vehicle to a complete stop, pull in the clutch lever/parking brake lever (1) and depress the shift lever (2) to shift into 1st gear.
2. Depress and hold down the rear brake pedal.
3. Be sure there are no obstacles or people in the way.
4. Leaving your left hand on the clutch lever/parking brake lever, remove your right hand from the throttle and place it on the reverse assist knob (3). Turn the reverse assist knob clockwise.

LEFT HANDLEBAR

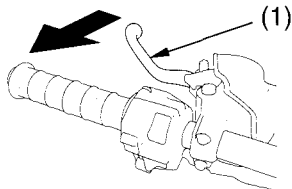

LEFT SIDE

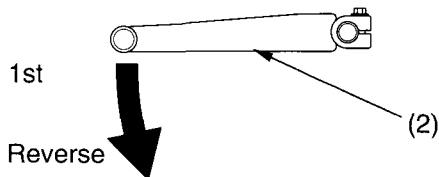

(1) clutch lever/
parking brake lever

(2) shift lever

Riding in Reverse

5. While turning the reverse assist knob, depress the shift lever to reach the reverse gear (below 1st gear). Make sure that the reverse indicator (4) comes on.
6. Remove your right hand from the reverse assist knob.
7. Release the rear brake pedal.
8. Slowly release the clutch lever/parking brake lever and open the throttle gradually to begin reverse operation.

RIGHT SIDE

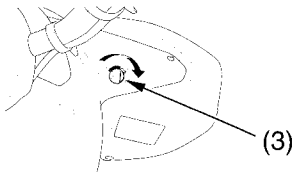

(3) reverse assist knob

CENTER OF HANDLEBAR

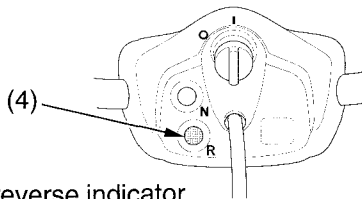

(4) reverse indicator

9. Ride slowly. Do not open the throttle suddenly or make abrupt turns.
10. To stop, pull in the clutch lever/parking brake lever, close the throttle and gradually apply both the front and rear brakes. Do not abruptly apply the rear brake by itself.
11. To shift out of reverse into 1st gear, pull in the clutch lever/parking brake lever and raise the shift lever one click to 1st gear. Make sure that the reverse indicator goes off.

⚠ WARNING

Applying only the rear brake abruptly when operating in reverse gear could cause the front wheels to lift off the ground and the ATV could overturn backwards.

Carefully apply both the front and rear brakes when stopping in reverse gear.

Braking

Your ATV is equipped with disc braking systems which are hydraulically activated. Depressing the brake pedal applies the rear disc brake. Operating the brake lever applies the front disc brake.

As a general rule, the front braking system provides about 70 percent of total stopping power.

For full braking effectiveness, use both the pedal and lever simultaneously. Using both braking systems will stop your ATV faster with greater stability.

To slow or stop, apply the brake lever and brake pedal smoothly, while downshifting to match your speed.

Gradually increase braking as you feel the brakes slowing your speed. The increase in engine compression from downshifting will help slow your ATV.

For maximum braking, close the throttle and firmly apply the brake lever and pedal controls.

Applying the brakes too hard may cause the wheels to lock and slide, reducing control of your ATV. If this happens, release the brake controls, steer straight ahead until you regain control, then reapply the brakes more gently.

When possible, reduce your speed or complete braking before entering a turn. Avoid braking or closing the throttle quickly while turning. Either action may cause one or more wheels to slip and reduce your control of your ATV.

Braking

Your ability to brake in a turn and to brake hard in an emergency situation are important riding skills.

When descending a long, steep grade, use engine compression braking by downshifting, with intermittent use of both brakes. Continuous brake application can overheat the brakes and reduce their effectiveness.

To prevent stalling the engine, pull the clutch lever/parking brake lever in before coming to a complete stop.

Riding with your foot resting on the brake pedal or your hand on the brake lever may overheat the brakes, reducing effectiveness.

For information on how to apply the brakes in various riding situations, see the following section, *Riding Your ATV*.

Riding Your ATV

Making Turns

Learn how to turn your ATV properly. Practice the techniques outlined in this section on level ground and at low speeds until you are confident in making turns.

WARNING

Turning improperly can make the ATV go out of control, causing a collision or overturn.

- Always follow proper procedures for turning as described in this owner's manual.
- Practice turning at low speeds before attempting to turn at faster speeds.
- Do not turn at excessive speeds.

Riding Your ATV

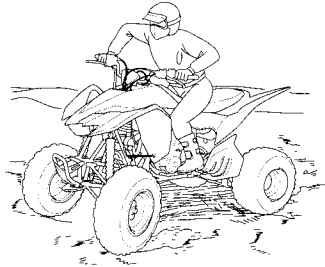
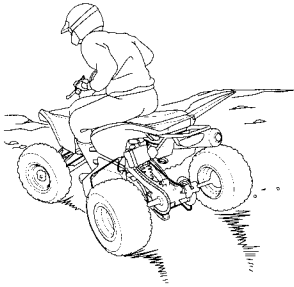

Lean your body to the inside of a turn and forward.

To make a turn on level ground: Steer the handlebar and lean your body toward the inside of the turn. Leaning helps balance the vehicle, and it feels more comfortable. Leaning into a turn is an important technique to master in riding an ATV.

To make a sharp turn at low speed: It helps to shift your body slightly forward on the seat, and lean inside, as you steer the handlebar. Shifting weight forward allows the rear wheels to turn easier, and it also improves front-wheel steering.

To make a turn from a full stop: Apply the throttle gradually when you turn and start up at the same time. Remember to shift your body forward to make sharp low-speed turns and whenever you turn while accelerating from a full stop.

Riding Your ATV

Skidding or Sliding

The terrain surface can be a major factor affecting turns. Skidding during a turn is more likely to occur on slippery surfaces, such as snow, ice, mud and loose gravel. If you skid on ice, you may lose all directional control. To avoid skidding on slippery terrain, keep your speed low and ride with caution.

WARNING

Skidding or sliding improperly may cause you to lose control of this ATV. You may also regain traction unexpectedly, which may cause the ATV to overturn.

Learn to safely control skidding by practicing at low speeds and on level, smooth terrain.

If your ATV skids sideways during a turn, steer in the direction of the skid. Avoid hard braking or accelerating until you have regained directional control.

Riding Your ATV

Riding Up Hills

The ATV's ability to safely climb hills largely depends on the rider's skill and judgment. Begin by practicing on smooth, gentle slopes. As you gain experience, you'll learn the hazards and your own limitations. You may then proceed to ride on more difficult terrain. However, you must be able to decide which hills or hazards might cause the ATV to overturn. Avoid excessively steep hills.

WARNING

Operating on excessively steep hills can cause the vehicle to overturn more easily than operating on level surfaces or small hills.

Never operate the ATV on hills too steep for the ATV or for your abilities.

When climbing hills, you must shift weight toward the front wheels to help keep them on the ground. To do this, shift your body slightly forward on the seat and lean forward. For greater weight shift, move your body farther forward and lean forward.

WARNING

Climbing hills improperly could cause loss of control or cause the ATV to overturn.

Always follow proper procedures for climbing hills as described in this owner's manual.

Riding Your ATV

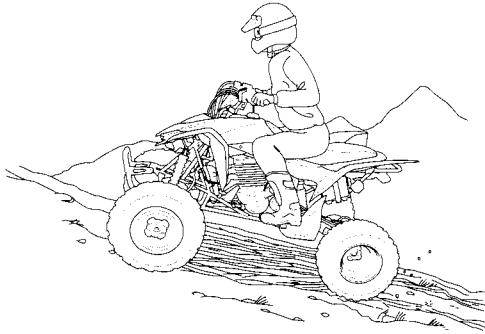

Shift weight forward when climbing hills.

- Always check the terrain carefully before you start up any hill.
- Never climb hills with excessively slippery or loose surfaces.
- To climb a hill, take a running start in an appropriate gear and speed for the conditions. Maintain a steady speed as you ascend the hill.
- Never open the throttle suddenly or make sudden gear changes. The ATV could flip over backward.
- Never go over the top of any hill at high speed. An obstacle, a sharp drop, or another vehicle or person could be on the other side of the hill.

Riding Your ATV

Stalling the ATV and/or Rolling Backwards:

If you incorrectly estimate climbing capability or terrain conditions, the ATV may not have enough power or traction to continue uphill. If this happens, the ATV can stall and/or roll backwards.

⚠ WARNING

Stalling, rolling backwards or improperly dismounting while climbing a hill could result in the ATV overturning.

Always follow proper procedures for climbing a hill as described in this owner's manual.

What to do if the ATV stalls or rolls backwards when climbing a hill:

If you are about to lose all forward speed:

1. Using the front and rear brakes together, bring the ATV to a stop with the vehicle pointed straight uphill.
2. Get off the ATV while you continue holding the brakes.
3. Shift into neutral, set the parking brake and turn the engine off.
4. Then assess the situation.

If the ATV starts rolling backwards before you begin braking:

1. Keep your weight uphill.
2. Carefully apply the front brakes first, then carefully apply the rear brake. Do not apply the rear brake only or abruptly if you are rolling backwards, or the vehicle may overturn.

If the ATV continues sliding backwards:

After you've applied the brakes, get off and away from the vehicle.

Riding Your ATV

What to do after the ATV has stalled or rolled backwards:

If the hill is too steep or too slippery, or if you have any doubt whether you can safely walk the ATV back down the hill, leave the vehicle where it is and get help. If possible, block the wheels so the vehicle doesn't roll backwards.

If the hill is not too steep and you have good footing, you may be able to walk the ATV back down the hill. Make sure your intended path is clear in case you lose control of the ATV.



Be sure your legs are clear of the wheels.

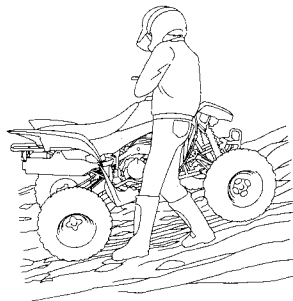

Body position for backing down a hill.

1. Stand with your body facing downhill, beside the vehicle so you can reach the front brake lever with your left hand.
2. Be sure your legs are clear of the wheels.
Check your footing.
3. Slowly and carefully back the ATV down the hill using the front brake lever to control speed.
4. If you lose control of the ATV, for your safety, get away from the vehicle.

Riding Your ATV

Riding Down Hills

It's usually advisable to descend hills with the ATV pointed straight downhill. Avoid angles that would cause the vehicle to lean sharply to one side.

▲ WARNING

Going down a hill improperly could cause loss of control or cause the ATV to overturn.

Always follow proper procedures for going down hills as described in this owner's manual.

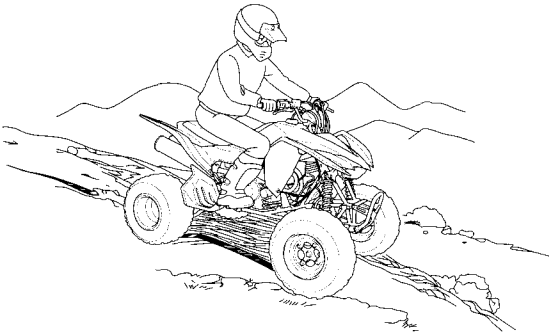

On downhills, shift your weight back.

As you approach a downhill, stop and survey the terrain below. Never ride past the limit of your visibility. Never go down a hill at high speed.

Riding Your ATV

When you've selected a safe downhill path, shift into a lower gear, shift your weight back with your arms extended and braced against the handlebar, then go down slowly with the throttle closed.

Use mainly the rear brake to control speed. Avoid using the front brake hard or abruptly when riding down hills.

Remember, braking effectiveness is reduced on any hill with a loose surface.

Crossing or Turning on Hills or Slopes

Riding on hills or slopes is different from riding on level terrain. Be careful when riding on any hill. Make sure that you practice on gentle, smooth slopes before attempting to ride on steeper or more difficult terrain.

⚠ WARNING

Improperly crossing hills or turning on hills could cause loss of control or cause the ATV to overturn.

Always follow proper procedures for crossing or turning on slopes as described in this owner's manual. Avoid crossing steep hills if possible.

Riding Your ATV

Crossing Hills or Slopes

- To maintain balance and stability when riding across a slope, you need to shift weight toward the uphill side of the vehicle. To do this, move your body off the center of the seat and lean toward the uphill side.
- On a slippery or loose surface, you may also need to steer slightly uphill to maintain a straight course across the slope.
- Avoid crossing hills that are excessively steep, slippery or rough.

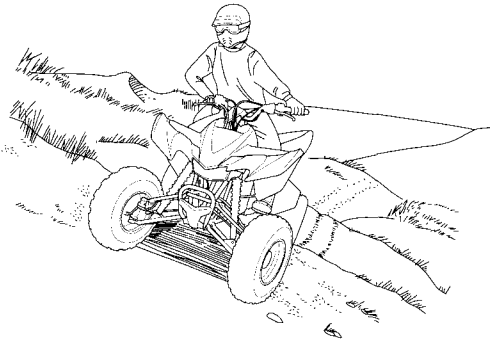

Shift weight uphill when crossing slopes.

Making Turns on Slopes

- Compared to riding on level ground, you may need to shift more weight and lean more when making turns on slopes.
- Do not make turns on any slopes until you have first mastered the techniques for making turns on level terrain.

Riding Your ATV

Riding Over Obstacles

Before operating in a new area, check for obstacles. Watch out for bumps, rain ruts, potholes and other obstacles in the terrain. When you approach any obstacle, reduce your speed and be prepared to stop. Never try to ride over large obstacles, such as large rocks or fallen logs.

WARNING

Improperly operating over obstacles could cause loss of control or a collision and could cause the ATV to overturn.

When you go over obstacles, always follow proper procedures as described in this owner's manual.