

2007

Honda TRX500FE/FPE

FOURTRAX FOREMAN 4×4 ES/with Power Steering

OWNER'S MANUAL

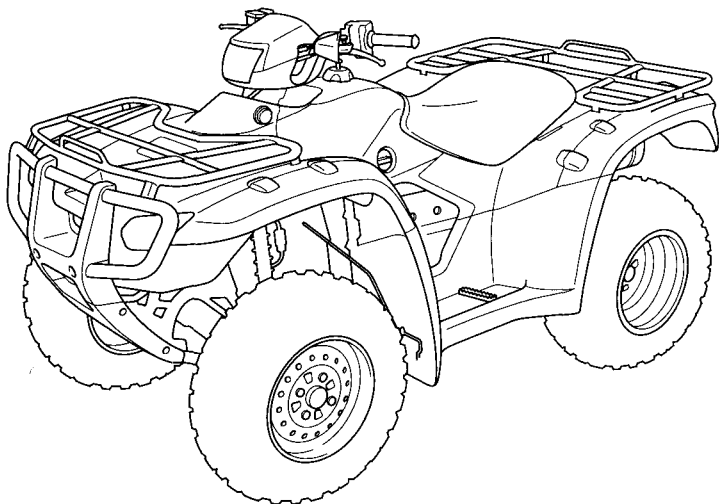

FOR OFF-ROAD USE ONLY

This vehicle is designed and manufactured for off-road use only.
USA only:

It conforms to US EPA Noise Emission regulations, but does not conform to Federal Motor Vehicle Safety Standards or US EPA On Highway Exhaust Emission regulations, and operation on public streets, roads, or highways is illegal. The vehicle is equipped with a USDA qualified spark arrester. Obey local laws and regulations.

It conforms to US EPA and California exhaust emission regulations for ATVs.

Introduction

Congratulations on choosing your Honda ATV.

When you own a Honda, you're part of a worldwide family of satisfied customers — people who appreciate Honda's reputation for building quality into every product.

Your Honda was designed as a recreational ATV for off-road use by one rider only.

Before riding, take time to get acquainted with your ATV and how it works. To protect your investment, we urge you to take responsibility for keeping your ATV well maintained. Scheduled service is a must, of course. But it's just as important to observe the break-in guidelines, and perform all pre-ride and other periodic checks detailed in this manual.

We also recommend that you read this owner's manual before you ride. It's full of facts, instructions, safety information, and helpful tips. To make it easy to use, the manual contains a detailed list of topics at the beginning of each section, and both an in-depth table of contents and an index at the back of the book.

As you read this manual, you will find information that is preceded by a **NOTICE** symbol. This information is intended to help you avoid damage to your Honda, other property, or the environment.

Read the Warranties Booklet (page 227) thoroughly so you understand the coverages that protect your new Honda and are aware of your rights and responsibilities.

Whenever you ride, tread lightly. By staying on established trails and riding only in approved areas, you help protect the environment and keep off-road riding areas open for the future.

Introduction

If you have any questions, or if you ever need special service or repairs, remember that your Honda dealer knows your ATV best and is dedicated to your complete satisfaction.

Please report any change of address or ownership to your Honda dealer so we will be able to contact you concerning important production information.

You may also want to visit our website at www.honda.com.

Happy riding!

California Proposition 65 Warning

WARNING: This product contains or emits chemicals known to the State of California to cause cancer and birth defects or other reproductive harm.

A Few Words About Safety

Your safety, and the safety of others, is very important. And operating this ATV safely is an important responsibility.

To help you make informed decisions about safety, we have provided operating procedures and other information on labels and in this manual. This information alerts you to potential hazards that could hurt you or others.

Of course, it is not practical or possible to warn you about all hazards associated with operating or maintaining an ATV. You must use your own good judgment.

You will find important safety information in a variety of forms, including:

Safety Labels — on the ATV.

Safety Messages — preceded by a safety alert symbol  and one of three signal words: **DANGER**, **WARNING**, or **CAUTION**.

A Few Words About Safety

These signal words mean:

▲ DANGER

You **WILL** be **KILLED** or **SERIOUSLY HURT** if you don't follow instructions.

▲ WARNING

You **CAN** be **KILLED** or **SERIOUSLY HURT** if you don't follow instructions.

▲ CAUTION

You **CAN** be **HURT** if you don't follow instructions.

Safety Headings — such as Important Safety Reminders or Important Safety Precautions.

Safety Section — such as ATV Safety.

Instructions — how to use this ATV correctly and safely.

This entire manual is filled with important safety information — please read it carefully.

Contents

These pages give an overview of the contents of your owner's manual. The first page of each section lists the topics covered in that section.

ATV Safety	1
Important safety information you should know, plus a look at the safety-related labels on your ATV.	
Instruments & Controls.....	9
The location and function of indicators and controls on your ATV and operating instructions for various controls and features.	
Before Riding.....	47
The importance of wearing a helmet and other protective gear, how to make sure you and your ATV are ready to ride, and important information about loading.	
Basic Operation & Riding	61
How to start and stop the engine, shift gears, and brake. Also, riding precautions.	

Contents

Servicing Your Honda	95
Why your ATV needs regular maintenance, what you need to know before servicing your Honda, an owner maintenance schedule, and instructions for specific maintenance and adjustment items.	
Tips	175
How to store and transport your ATV and how to be an environmentally-responsible rider.	
Taking Care of the Unexpected	185
What to do if you have a flat tire, your engine won't start, etc.	
Technical Information	207
ID numbers, technical specifications, and other technical facts.	
Consumer Information	223
Information on warranties, emission controls, how to get Honda service manuals.	
Table of Contents	232
Sequential listing of topics in this owner's manual.	
Index	238
Quick Reference	
Handy facts about fuel, engine oil, tire sizes, and air pressures.	

ATV Safety

This section presents some of the most important information and recommendations to help you ride your ATV safely. Please take a few moments to read these pages. This section also includes information about the location of safety labels on your ATV.

Important Safety Information	2
Safety Labels.....	5

Important Safety Information

Your ATV can provide many years of service and pleasure — if you take responsibility for your own safety and understand the challenges you can meet while riding.

There is much that you can do to protect yourself when you ride. You'll find many helpful recommendations throughout this manual. The following are a few that we consider most important.

Follow the Age Recommendation

The minimum recommended age for this ATV model is 16. Children under age 16 should never operate this vehicle.

Always Wear a Helmet

It's a proven fact: helmets significantly reduce the number and severity of head injuries. So always wear an approved motorcycle helmet. We also recommend that you wear eye protection, sturdy boots, gloves, and other protective gear (page 48).

Never Carry a Passenger

Your ATV is designed for one person only. There are no handholds, footrests, or seat for a second person — so never carry a passenger. A passenger could interfere with your ability to move around to maintain your balance and control of the ATV.

Important Safety Information

Ride Off-Road Only

Your ATV is designed and manufactured for off-road use only. The tires are not made for pavement, and the ATV does not have turn signals and other features required for use on public roads. If you need to cross a paved or public road, get off and walk your ATV across.

Take Time to Learn & Practice

Even if you have ridden other ATVs, take time to become familiar with how this ATV works and handles. Practice in a safe area until you build your skills and get accustomed to the ATV's size and weight.

Because many accidents involve inexperienced or untrained riders, we urge all riders to take a training course approved by the ATV Safety Institute (ASI). See page 50.

Contact an authorized ATV dealer or call 1-800-887-2887 (USA only) to find out about the training courses nearest you.

Be Alert for Off-Road Hazards

The terrain can present a variety of challenges when you ride off-road. Continually "read" the terrain for unexpected turns, drop-offs, rocks, ruts, and other hazards. Always keep your speed low enough to allow time to see and react to hazards.

Important Safety Information

Ride within Your Limits

Pushing limits is another major cause of ATV accidents. Never ride beyond your personal abilities or faster than conditions warrant. Remember that alcohol, drugs, fatigue, and inattention can significantly reduce your ability to make good judgments and ride safely.

Don't Drink and Ride

Alcohol and riding don't mix. Even one drink can reduce your ability to respond to changing conditions, and your reaction time gets worse with every additional drink. So don't drink and ride, and don't let your friends drink and ride either.

Keep Your Honda in Safe Condition

It's important to keep your ATV properly maintained and in safe riding condition. Having a breakdown can be difficult, especially if you are stranded off-road far from your base. To help avoid problems, inspect your ATV before every ride and perform all recommended maintenance.

Safety Labels

Your ATV comes with a hang tag and several labels containing important safety information. Anyone who rides the vehicle should read and understand this information before riding.

The labels should be considered permanent parts of the vehicle. If a label comes off or becomes hard to read, contact your Honda dealer for replacements.

Safety Labels

USA only

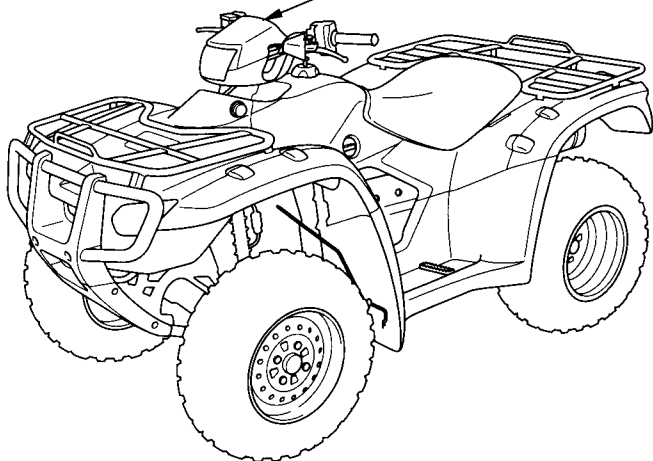
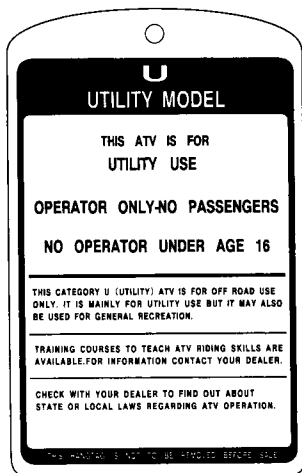
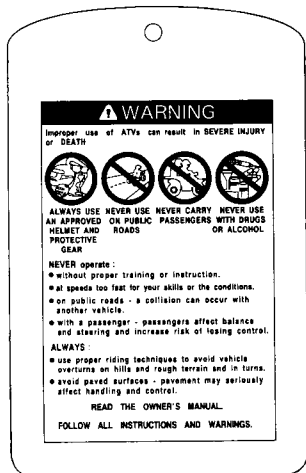

Safety Labels

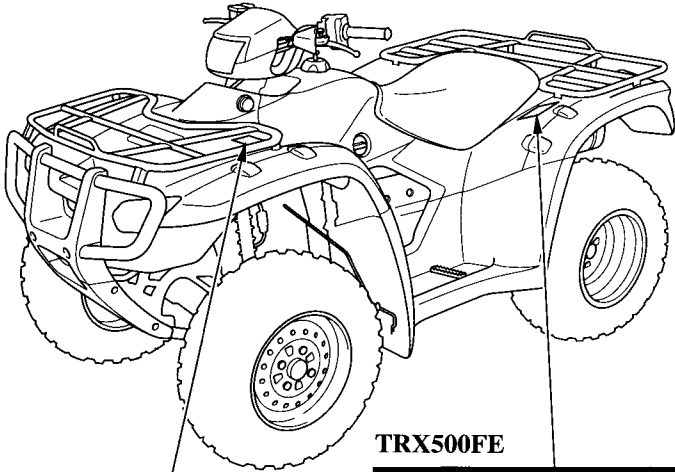

TRX500FE

WARNING

Overloading this ATV or carrying cargo improperly can change handling, stability and braking performance and can lead to an accident.

Never exceed the maximum front cargo limit of: **66lbs (30kg)**.

Refer to instructions in the Owner's Manual.

WARNING

Improper tire pressure or overloading can cause loss of control. Loss of control can result in severe injury or death.

- Cold tire pressure ;
Front : 25±3kpa 0.25±0.03kgf/cm² 3.6±0.4psi
Rear : 25±3kpa 0.25±0.03kgf/cm² 3.6±0.4psi
- Maximum weight capacity ; 220kg 485lbs.

TRX500FPE

WARNING

Improper tire pressure or overloading can cause loss of control. Loss of control can result in severe injury or death.

- Cold tire pressure ;
Front : 30·4kPa 0.30·0.04kgf/cm² 4.4·0.6psi
Rear : 25·3kPa 0.25·0.03kgf/cm² 3.6·0.4psi
- Maximum weight capacity ; 220kg (485lbs.)

Safety Labels

WARNING



Operating this ATV if you are under the age of 16 increases your chance of severe injury or death.

NEVER operate this ATV if you are under age 16.

BRAKING INFORMATION

With four-wheel drive, operating any brake control causes braking at both the front and rear wheels. For detailed braking information, refer to the Owner's Manual.

WARNING

Improper use of ATVs can result in SEVERE INJURY or DEATH



ALWAYS USE AN APPROVED HELMET AND PROTECTIVE GEAR. NEVER USE ON PUBLIC ROADS. NEVER CARRY PASSENGERS. NEVER USE WITH DRUGS OR ALCOHOL.

NEVER operate:

- without proper training or instruction.
- at speeds too fast for your skills or the conditions.
- on public roads - a collision can occur with another vehicle.
- with a passenger - passengers affect balance and steering and increase risk of losing control.

ALWAYS:

- use proper riding techniques to avoid vehicle overturns on hills and rough terrain and in turns.
- avoid paved surfaces - pavement may seriously affect handling and control.

READ THE OWNER'S MANUAL.

FOLLOW ALL INSTRUCTIONS AND WARNINGS.

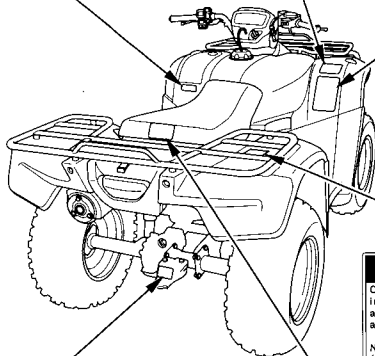

WARNING

Towing an improperly loaded trailer can cause loss of control.

- Read owner's manual.
- Tow weight limit :3776N {385kgf} 850lbs
- Tongue weight : 137N { 14kgf} 30lbs

WARNING

Overloading this ATV or carrying cargo improperly can change handling, stability and braking performance and can lead to an accident.

Never exceed the maximum rear cargo limit (combined weight on the rear rack and in the storage area) of: 133lbs (60kg).

Refer to instructions in the Owner's Manual.

WARNING



NEVER ride as a passenger. Passengers can cause a loss of control, resulting in SEVERE INJURY or DEATH.

Instruments & Controls

This section shows the location of all indicators and controls you would normally use before or while riding your ATV.

The items listed on this page are described in this section. Instructions for other components are presented in other sections of this manual where they will be most useful.

Operation Component Locations	11
Indicators & Displays.....	14
Multi-function Display.....	18
Gear Position Indicator.....	19
Oil Change Indicator	20
Odometer/Tripmeter.....	21
Hourmeter	23
Digital Clock	24
Fuel Gauge	26

(cont'd)

Instruments & Controls

Controls & Features	27
Fuel Valve	27
Choke Knob	28
Ignition Switch	29
2WD/4WD Select Switch	30
Start Button	31
Engine Stop Switch	31
Headlight Switch	32
Headlight Dimmer Switch	32
Starting Primer Knob	33
Recoil Starter	33
Throttle Lever	34
Gearshift Switch	35
Reverse Selector Knob	36
Front Brake Lever	37
Rear Brake Lever	37
Rear Brake Pedal	37
Parking Brake	38
Flag Pole Bracket	39
Trailer Hitch	40
Accessory Socket	41
Utility Box	43
Storage Compartment	44
PS (Electric Power Steering) (TRX500FPE only)	45

Operation Component Locations

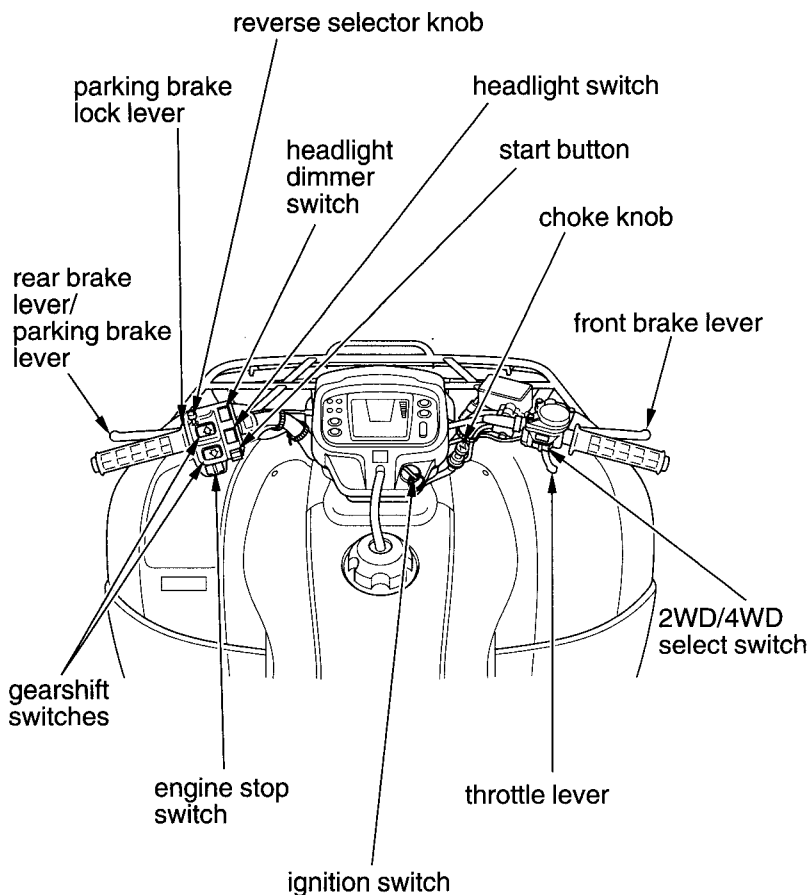

Instruments & Controls 11

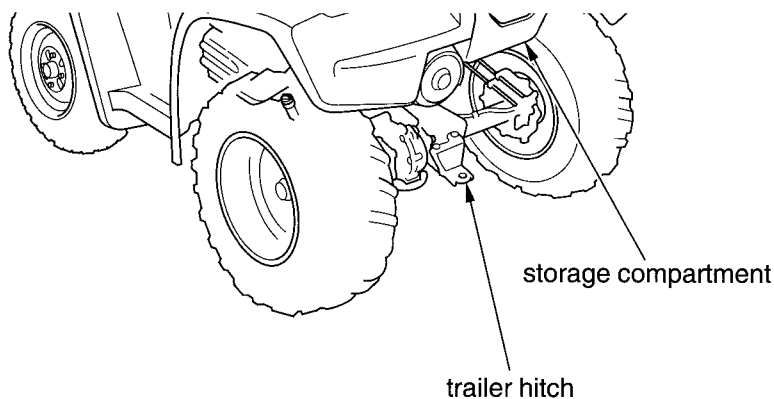

Instruments & Controls 13

Operation Component Locations

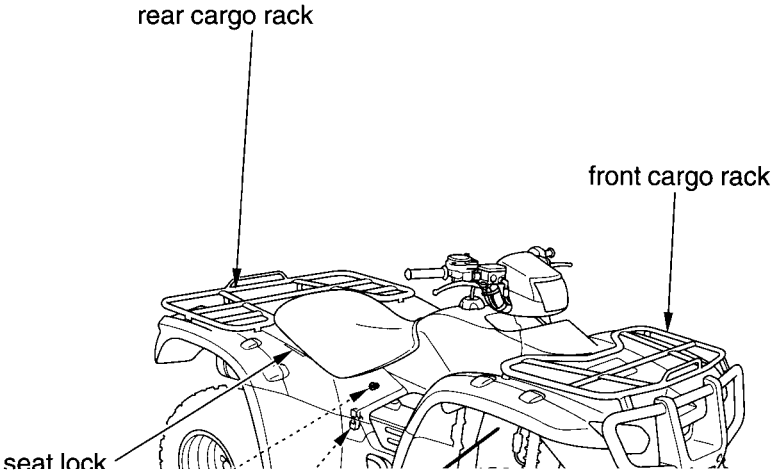

Indicators & Displays

The indicators and displays on your ATV keep you informed, alert you to possible problems, and make your riding safer and more enjoyable. Refer to the indicators frequently. Their functions are described on the following pages.

TRX500FE

TRX500FPE

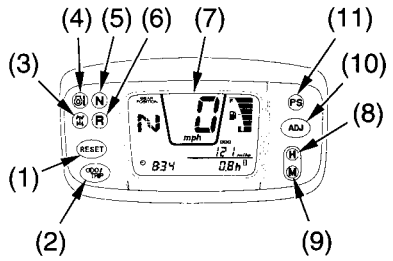
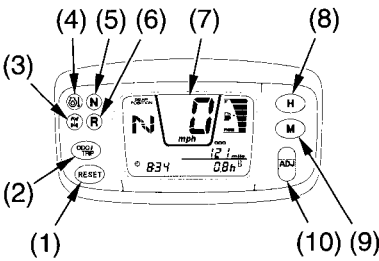

- (1) RESET button
- (2) odometer/tripmeter select button
- (3) 4WD indicator
- (4) high oil temperature indicator
- (5) neutral indicator
- (6) reverse indicator

- (7) multi-function display
- (8) hour select button
- (9) minute select button
- (10) adjust button
- (11) PS (Electric Power Steering) indicator (TRX500FPE only)

USA: Displays read in mph and miles.

Canada: Displays read in km/h and kilometers.

Indicators & Displays

Lamp Check

The high oil temperature indicator, neutral indicator, 4WD indicator and reverse indicator come on for a few seconds and then go off when you turn the ignition switch ON (I).

TRX500FPE only:

The PS (Electric Power Steering) indicator comes on when you turn the ignition switch ON (I) so you can check that it is working.

The indicator remains on until the engine is started.

These indicators are identified in the table on pages 16 – 17 with the words: *Lamp Check*.

When applicable, the reverse or neutral indicators come on when you turn the ignition switch ON (I) and remain on until you shift out of reverse or neutral.

If one of these indicators does not come on when it should, have your Honda dealer check for problems.

Display Check

When the ignition switch is turned ON (I), the multi-function display (1) will temporarily show all the modes and digital segments so you can make sure the liquid crystal display is functioning properly.

The displays are identified in the table on page 17 with the words: *Display Check*.

If any part of these displays does not come on when it should, have your Honda dealer check for problems.

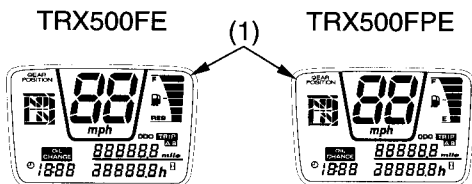

(1) multi-function display

Indicators & Displays

1	RESET button	Resets the tripmeter to zero (0) (page 22). This button also used to reset the oil change indicator (page 20).
2	Odometer/tripmeter select button	Selects display of the odometer or tripmeter A or tripmeter B (page 21). This button also used to reset the oil change indicator (page 20).
3	4WD indicator	Lights when the drive mode is in the 4WD mode. The 4WD indicator blinks if there is a possible problem with the 2WD/4WD select system. See your Honda dealer as soon as possible. <i>Lamp Check.</i>
4	High oil temperature indicator	Lights when engine oil temperature is high enough to adversely affect the service life of the engine. If the high oil temperature indicator comes on while you are riding, immediately bring the vehicle to a stop, turn the engine off and let it cool. See page 197. <i>Lamp Check.</i>
5	Neutral indicator	Lights when the transmission is in neutral. <i>Lamp Check.</i>
6	Reverse indicator	Lights when the transmission is in reverse. <i>Lamp Check.</i>

Indicators & Displays

7	Multi-function display	The display includes the following functions. <i>Display Check</i> .
	Gear position indicator	Shows the gear position (page 19).
	Speedometer	Shows riding speed.
	Fuel gauge	Shows approximate fuel supply available (page 26).
	Oil change indicator	Lights when specified maintenance interval for engine oil change is reached (page 20).
	Odometer	Shows accumulated mileage (page 21).
	Tripmeter	Shows mileage per trip (page 21).
	Hourmeter	Shows hours and tenths of hours of engine operation (page 23).
	Digital clock	Shows the time (hours and minutes) (page 24).
8	Hour select button	Advances the hour displayed by the digital clock (page 24).
9	Minute select button	Advances the minutes displayed by the digital clock (page 24).
10	Adjust button	Used to set the digital clock (page 24).
11	PS (Electric Power Steering) indicator (TRX500FPE only)	Lights when there is an abnormality in the PS (Electric Power Steering) system. See page 45 . <i>Lamp Check</i> .

Indicators & Displays

Multi-function Display

The multi-function display (1) includes the following functions:

Gear position indicator	Tripmeter
Oil change indicator	Digital clock
Speedometer	Hourmeter
Odometer	Fuel gauge

TRX500FE:

The digital clock will reset if the battery is disconnected.

TRX500FPE:

The digital clock and tripmeter will reset if the battery is disconnected.

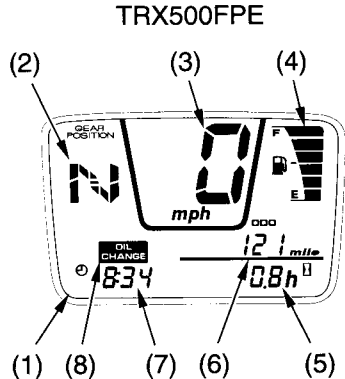
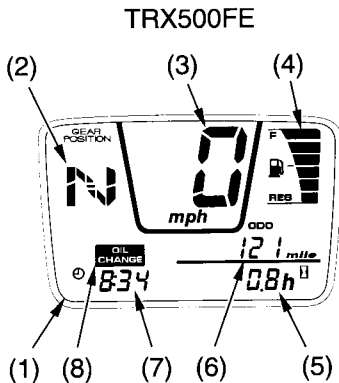

- (1) multi-function display
- (2) gear position indicator
- (3) speedometer
- (4) fuel gauge

- (5) hourmeter
- (6) odometer/tripmeter
- (7) digital clock
- (8) oil change indicator

Indicators & Displays

Gear Position Indicator

The gear position indicator (1) shows the gear position when the ignition switch is in the ON (I) position.

The indicator displays: N for neutral, R for reverse, and 1 – 5 for the five forward gears.

“- -” will be displayed on the gear position indicator when the transmission is not shifted into gear properly. Before riding, check that the gear position is displayed on the gear position indicator properly.

If the gear position indicator shows “- -” and blinks, turn the ignition switch to the OFF (O) position, and then turn it back to the ON (I) position again. If the gear position indicator still shows “- -” and blinks, see your Honda dealer.

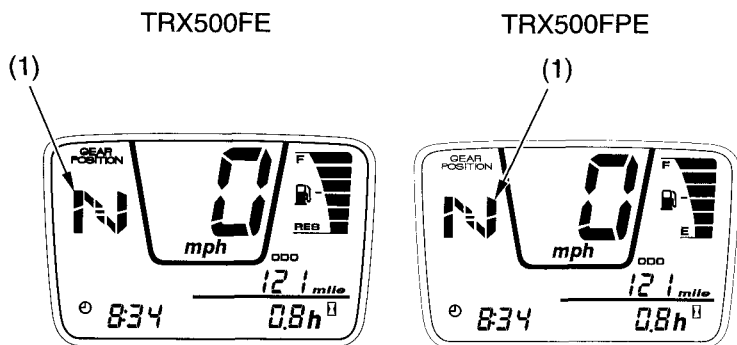

(1) gear position indicator

Indicators & Displays

Oil Change Indicator

The oil change indicator (1) appears in the display when the mileage or operating hours on your ATV approaches the oil change interval specified on the maintenance schedule.

Reset the indicator after each oil change.

To reset the indicator, press and hold both the odometer/tripmeter select button (2) and RESET button (3) for more than 2 seconds. The indicator will disappear.

If the oil is changed before the oil change indicator appears, be sure to reset the oil change indicator after changing the oil. The indicator will appear for 2 seconds, then disappear. This means the indicator is reset.

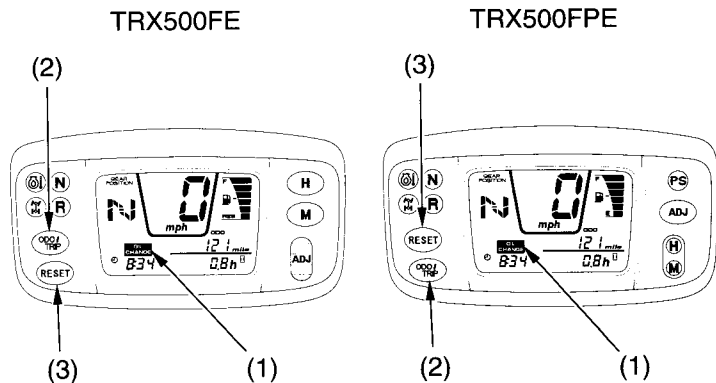

(1) oil change indicator
(2) odometer/tripmeter
select button

(3) RESET button

Indicators & Displays

Odometer/Tripmeter

The odometer/tripmeter display has two functions, odometer (1) and tripmeter.

The tripmeter has two sub modes, A (2) and B (3).

The odometer registers total distance traveled in miles while the ignition switch is ON (1).

The tripmeter shows mileage per trip while the ignition is ON (1).

To change the display from tripmeter A or tripmeter B to odometer, press and release the odometer/tripmeter select button (4).

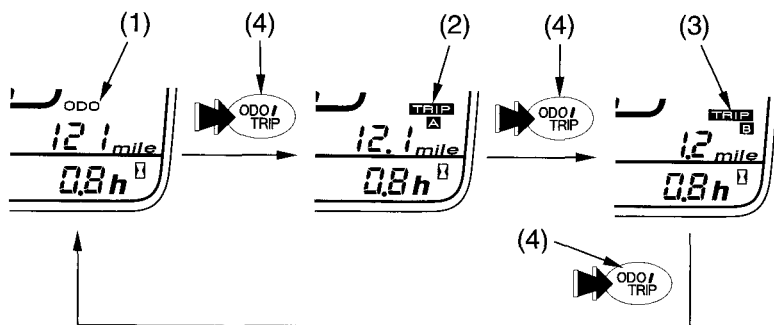

- (1) odometer
- (2) tripmeter A

- (3) tripmeter B
- (4) odometer/tripmeter select button

Indicators & Displays

To reset the tripmeter to zero, press and hold the RESET button (5) for more than 2 seconds with the display in the tripmeter A or tripmeter B mode.

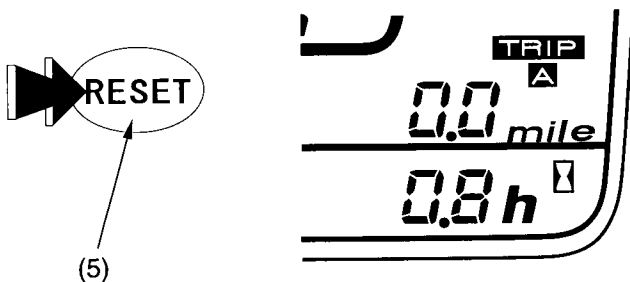

(5) RESET button

Indicators & Displays

Hourmeter

The hourmeter (1) shows accumulated hours while the ignition is ON (1). The hourmeter provides accurate service period information for initial and regular maintenance.

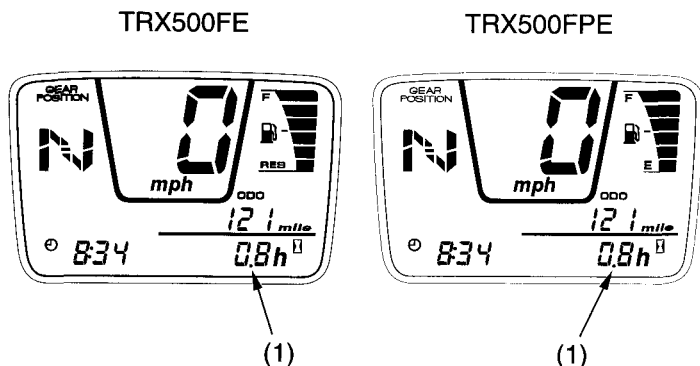

(1) hourmeter

Indicators & Displays

Digital Clock

Shows hour and minute while the ignition is ON (1).

To adjust the time, proceed as follows:

1. Turn the ignition switch ON (1).
2. TRX500FE:
To put the clock in the adjust mode with the hour and minute display flashing, press and hold the adjust button (1) for more than 2 seconds.
TRX500FPE:
To select the adjust mode, push the adjust button (1) once.
3. To advance the hour display one unit at a time, press and release the hour select button (2).
To advance the hour display automatically, press and hold the hour select button. After 2 seconds, the hour display will begin advancing. Release the button when the display reaches the desired hour.
4. To advance the minute display one unit at a time, press and release the minute select button (3).
To advance the minute display automatically, press and hold the minute select button. After 2 seconds, the minute display will begin advancing. Release the button when the display reaches the desired minute.
5. To zero the minute display, press and hold both the hour and minute select buttons simultaneously for 2 seconds.
6. TRX500FE:
Press and hold the adjust button for more than 2 seconds when the display reaches the desired minute. The display will stop flashing.
TRX500FPE:
Press the adjust button when the display reaches the desired minute. The display will stop flashing.

Indicators & Displays

TRX500FE

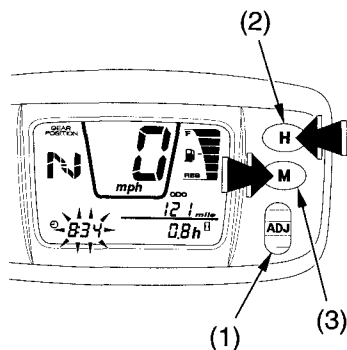

- (1) adjust button
- (2) hour select button

TRX500FPE

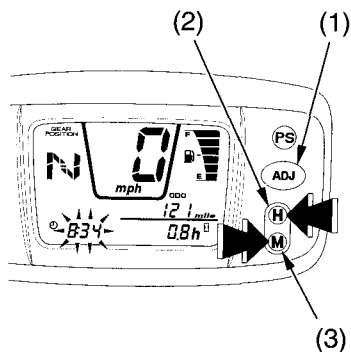

- (3) minute select button

Indicators & Displays

Fuel Gauge

The fuel gauge liquid crystal display (1) shows the approximate fuel supply available. The fuel tank capacity is:

4.17 US gal (15.8 ℓ)

TRX500FE:

When segment RES (2) flashes, you should refill the tank as soon as possible. The amount of fuel remaining when the flashing starts is approximately:

0.87 US gal (3.3 ℓ)

TRX500FPE:

When segment E (3) and low fuel indicator (4) flash, you should refill the tank as soon as possible. The amount of fuel remaining when the flashing starts is approximately:

0.87 US gal (3.3 ℓ)

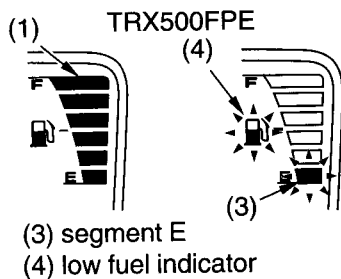
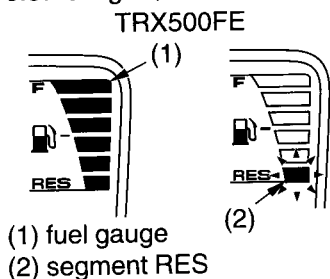

All segments will flash, when the fuel gauge function is fails. See your Honda dealer.

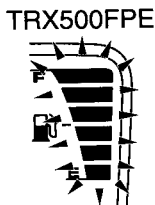

Controls & Features

Fuel Valve

LEFT SIDE

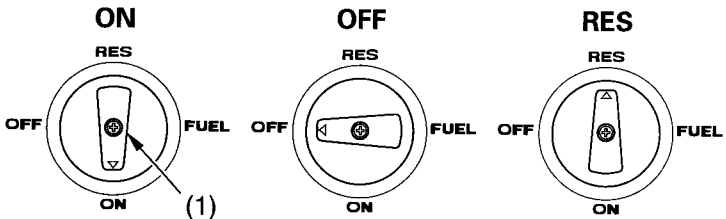

(1) fuel valve

The manual fuel valve (1) is located on the left side of the fuel tank cover.

The three-way fuel valve is used to control the flow of fuel from the fuel tank to the carburetor.

ON—normal position for riding.

OFF—for parking, storing, or transportation.

RES—for extra fuel to get to a gas supply for refueling.

Reserve Fuel

Remember to check that the fuel valve is in the ON position each time you refuel. If the fuel valve is left in the RES position, you may run out of fuel with no reserve.

For complete information about fueling your ATV, see page 111.

Controls & Features

Choke Knob



CENTER OF HANDLEBAR

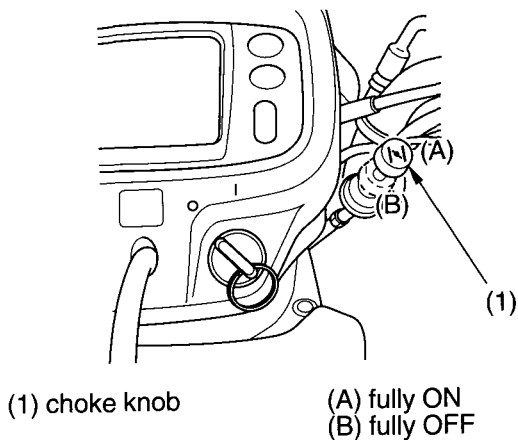

The choke knob (1) may be used when starting the engine. See page 69 .

Controls & Features

Ignition Switch

The ignition switch (1) is used for starting and stopping the engine (page 68). Insert the key and turn it to the right for the ON (I) position.

Key Position	Function
ON (I)	Electrical circuits on.
OFF (O)	No electrical circuits function.

CENTER OF HANDLEBAR

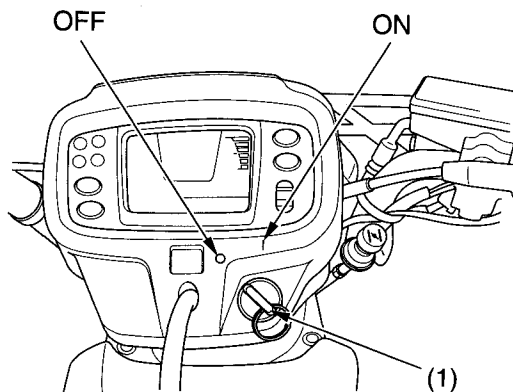

(1) ignition switch

I ON
O OFF

Controls & Features

2WD/4WD Select Switch

Your ATV is equipped with a 2WD/4WD select switch (1), which permits a choice between the “2WD” and “4WD” drive modes. Select a drive mode that’s suitable for your riding.

The 2WD/4WD select switch is located above the throttle lever. To select the drive mode, slide the 2WD/4WD select switch to the desired position.

To check your present drive mode, look at the 4WD indicator (2).

2WD mode : the 4WD indicator goes off.

4WD mode : the 4WD indicator goes on.

4WD can only be engaged while the engine is running.

It remains engaged until the 2WD mode is selected or the engine is stopped.

Upon starting, your ATV will be in the 2WD mode, regardless of the 2WD/4WD select switch position.

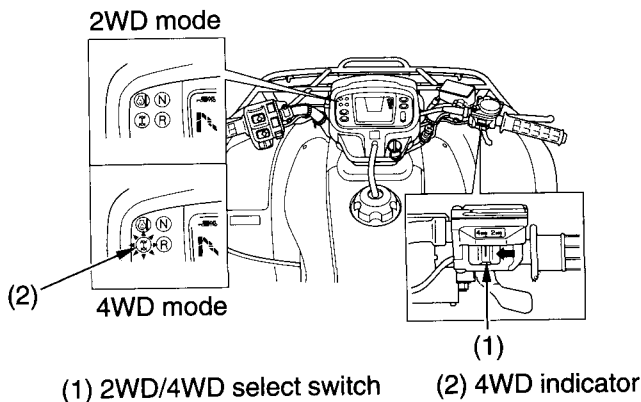

Controls & Features

Start Button



LEFT HANDLEBAR

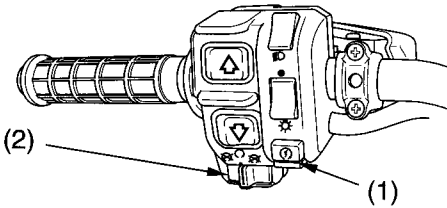

(1) start button

(2) engine stop switch

 START

 OFF



 RUN



The start button (1) is used for starting the engine. Pushing the button in starts the engine. See *Starting Procedure*, page 69.

When the start button is pushed, the starter motor will crank the engine. The starter motor will not operate if the engine stop switch is in the OFF () position when the start button is pushed.

Engine Stop Switch



The engine stop switch (2) is used to stop the engine in an emergency. To operate, slide the switch to the OFF () position. The switch must be in the RUN () position to start the engine, and it should normally remain in the RUN () position even when the engine is OFF.

If your ATV is stopped with the ignition switch ON () and the engine stop switch OFF (), the battery will discharge. Turn the ignition switch OFF () to prevent battery discharge.

Controls & Features

Headlight Switch



LEFT HANDLEBAR

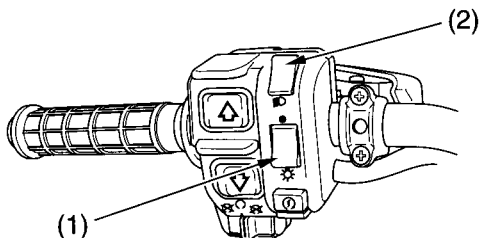

(1) headlight switch

(2) headlight dimmer switch

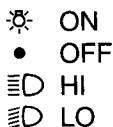

The headlight switch (1) is used to turn the headlights and assist headlight ON (☀) or OFF (•). To operate, turn the switch to ON (☀) or OFF (•).

Headlight Dimmer Switch



The headlight dimmer switch (2) is used to change between the high and low beams of the headlight. To operate, turn the switch to HI (≡) for high beam, LO (≡) for low beam.

The headlight dimmer switch will not change the assist headlight beam.

Controls & Features

Starting Primer Knob

RIGHT SIDE

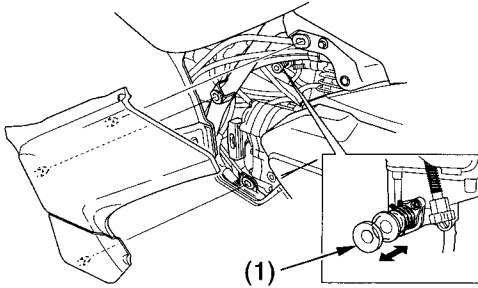

(1) starting primer knob

The starting primer knob (1) is located on the carburetor float bowl. The knob may be used when starting the engine in extremely cold weather (-15°C , 5°F). See *Starting Procedure*, page 69 .

Recoil Starter

RIGHT SIDE

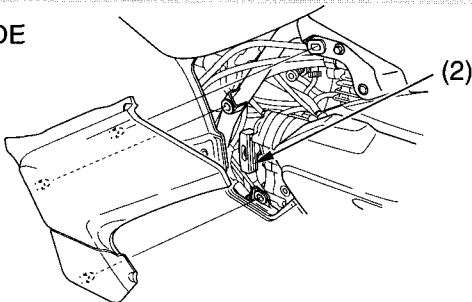

(2) recoil starter

The recoil starter (2) is used to start the engine when the battery is low. See *Using the Recoil Starter*, page 73 .

Controls & Features

Throttle Lever

RIGHT HANDLEBAR

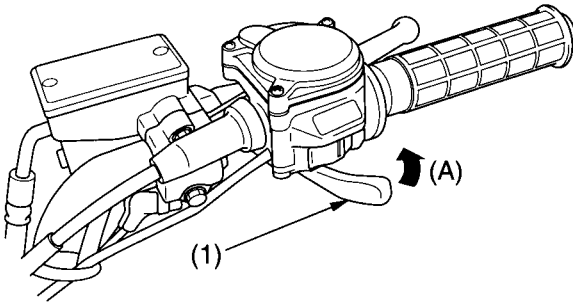

(1) throttle lever

(A) to open the throttle

The throttle controls engine rpm (speed). To increase engine rpm, press the throttle lever (1) with your thumb. To reduce engine rpm, release pressure on the throttle lever. The throttle will automatically return to the closed position (engine idle) when you remove your thumb.

Controls & Features

Gearshift Switch

These switches are used to select the next higher or lower gear in the transmission. To operate, press the upshift switch (1) to engage the next higher gear or press the downshift switch (2) to engage the next lower gear.

See *Shifting Gears*, page 74 .

LEFT HANDLEBAR

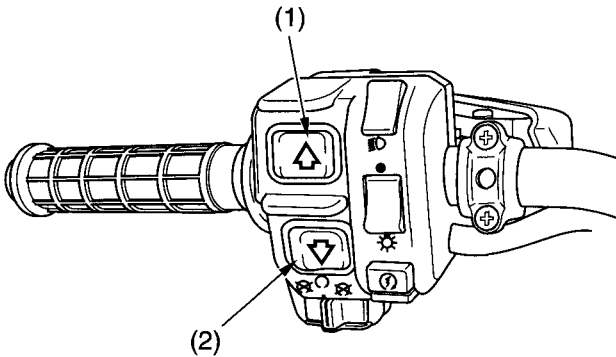

- (1) upshift switch
- (2) downshift switch

Controls & Features

Reverse Selector Knob

The reverse selector knob (1), located on the rear brake lever/parking brake lever (2), is used to shift into reverse. To operate, with your ATV stopped and the transmission in neutral (make sure the gear position indicator shows “N”), push in the knob, squeeze the rear brake lever/parking brake lever, then press the downshift switch (3) once. See *Riding in Reverse*, page 77.

LEFT HANDLEBAR

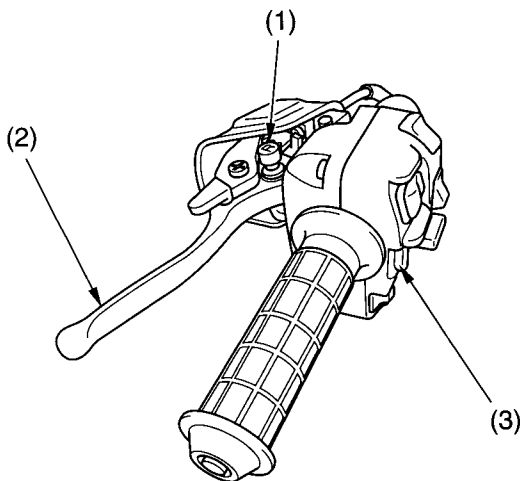

- (1) reverse selector knob
- (2) rear brake lever/parking brake lever
- (3) downshift switch

Controls & Features

Front Brake Lever

The front brake lever is used to slow or stop your ATV. To operate, pull the lever. For information on braking techniques, see page 79 .

Rear Brake Lever

The rear brake lever is used to slow or stop your ATV. To operate, pull the lever. For information on braking techniques, see page 79 .

Rear Brake Pedal

The rear brake pedal is used to slow or stop your ATV. To operate, depress the pedal. For information on braking techniques, see page 79 .

Controls & Features

Parking Brake

LEFT HANDLEBAR

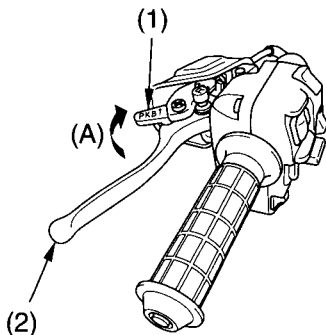

(1) lock lever

(A) to lock

(2) rear brake lever/parking brake lever

The lock lever (1) on the rear brake lever/parking brake lever (2) allows it to be used as a parking brake. To operate, first squeeze the rear brake lever/parking brake lever using your left hand and then lock it with the lock lever using your right hand. See *Parking* page 93 .

The brakelights are activated by applying the parking brake. When using the parking brake, be sure to turn the ignition switch OFF (○) to avoid discharging the battery.

Controls & Features

Flag Pole Bracket

RIGHT REAR

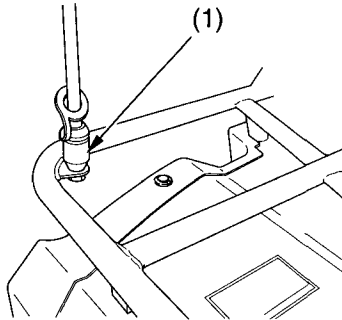

(1) flag pole bracket

Flag poles are optional equipment available from your Honda dealer. To mount a pole in the bracket (1), follow the instructions that come with the flag pole kit.

Flag poles are required in some riding areas. Check local regulations before riding.

Controls & Features

Trailer Hitch

REAR

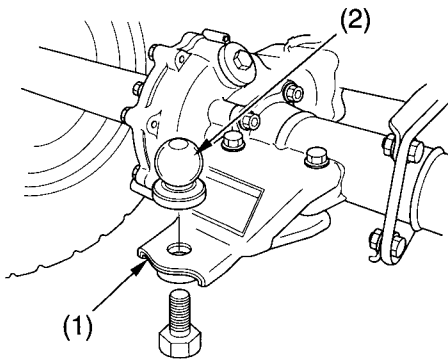

(1) trailer hitch

(2) ball

The trailer hitch (1) is located on the rear axle housing. To use the hitch, you'll need a proper size ball (2) as specified by the trailer manufacturer.

To attach the ball and properly hook up a trailer, follow the trailer manufacturer's instructions. For load limits and operational guidelines, see page 57.

Controls & Features

Accessory Socket

LEFT FRONT

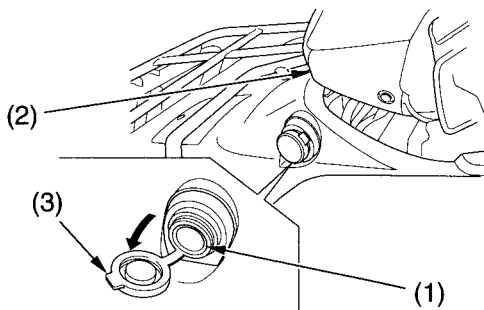

(1) accessory socket
(2) assist headlight

(3) cap

The accessory socket (1) is attached to the left side under the assist headlight (2). You can use the accessory socket to power a trouble light, spotlight, CB radio, or cell phone, etc.

NOTICE

Do not plug in any heat-generating accessory such as an automobile cigarette lighter because it can damage the socket.

To use the accessory socket, turn the ignition switch ON (|), start the engine. Then turn the headlights OFF (•), and open the accessory socket cap (3).

Controls & Features

Be sure the engine is on and the headlights are turned off before using the accessory socket, otherwise you may drain the battery.

The accessory socket's rated capacity is DC 12V, 120 Watts (10A) or less. If you exceed this limit, you may blow a fuse. See *If a Fuse Blows*, page 198 .

When you are done using an accessory, unplug it, and cover the socket with the cap.

Be careful not to flood this accessory socket when washing your ATV.

Controls & Features

Utility Box

The utility box (1) is located on the left side of the front fender. You may store small, lightweight items in the box.

To open:

Lift the D-ring (2) on the quick-release fastener. Turn it counterclockwise until it releases. Open the utility box cover (3).

To close:

Close the cover and turn the D-ring clockwise until it secures the cover.

LEFT FRONT FENDER

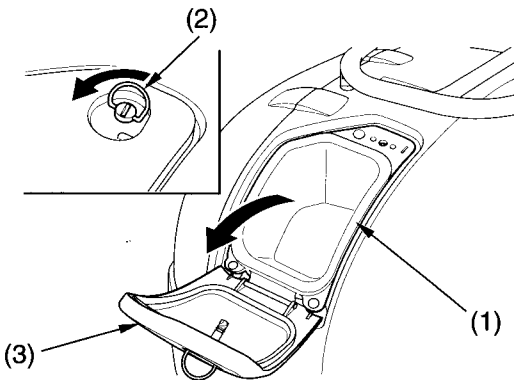

(1) utility box
(2) D-ring

(3) utility box cover

Controls & Features

Storage Compartment

The storage compartment (1) is located below the rear cargo rack (2).

To open the compartment, unhook the rubber strap (3).

Be careful not to flood this area when washing your ATV.

REAR

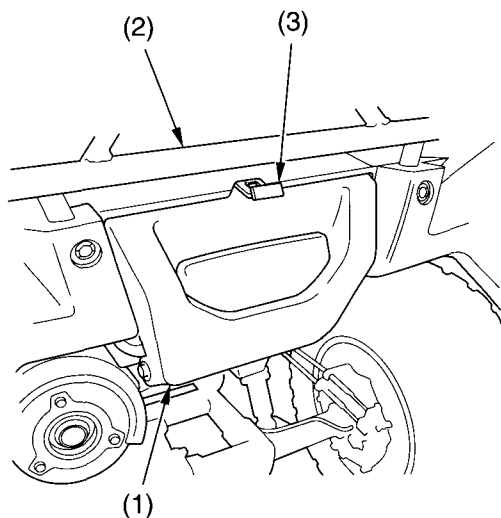

- (1) storage compartment
- (2) rear cargo rack
- (3) rubber strap

Controls & Features

PS (Electric Power Steering) (TRX500FPE only)

This ATV is equipped with an electronically-controlled, electric-power-assisted steering system.

While the engine running, the PS (Electric Power Steering) system provides power from the electric motor, which helps you to turn ATV's handlebar more easily.

Under extreme conditions, the PS system reduces power that helps easily steer the handlebar. This can prevent the system from overheating caused by either continuously turning the handlebar at low speed or continuously applying high torque to the steering shaft. Under such conditions, you may feel the handlebar heavier, but it is not a malfunction.

The PS indicator should light when the ignition switch turned ON (I) and remain on until the engine is started.

The PS indicator also lights when there is any abnormality in the PS system. If this occurs, the electric power assist for turning will not be available, but the manual steering system will perform as usual.

If the PS indicator lights at any time while riding, reduce speed and take your ATV to a Honda dealer as soon as possible. Continuing to ride with a PS system problem can cause system damage.

Do not modify your Electric Power Steering system. In case of a malfunction, take your ATV to a Honda dealer.

Before Riding

Before each ride, you need to make sure you and your Honda are both ready to ride. To help get you prepared, this section discusses how to evaluate your riding readiness, what items you should check on your ATV, and adjustments to make for your comfort, convenience, or safety. This section also includes important information about loading.

Are You Ready to Ride?	48
Protective Apparel.....	48
Rider Training	50
Age Recommendation.....	51
No Passengers	51
No Alcohol or Drugs.....	52
Is Your ATV Ready to Ride?.....	53
Pre-ride Inspection	53
Load Limits & Guidelines.....	56
Loading	56
Load Limits	57
Loading Guidelines	58
Accessories & Modifications	59
Accessories.....	59
Modifications	60

Are You Ready to Ride?

Before you ride your ATV for the first time, we urge you to:

- Read this owner's manual and the labels on your ATV carefully.
- Make sure you understand all the safety messages.
- Know how to operate all the controls.

Before each ride, be sure:

- You feel well and are in good physical and mental condition.
- You are wearing an approved motorcycle helmet (with chin strap tightened securely), eye protection, and other protective clothing.
- You don't have any alcohol or drugs in your system.

Protective Apparel

For your safety, we strongly recommend that you always wear an approved motorcycle helmet, eye protection, boots, gloves, long pants, and a long-sleeved shirt or jacket whenever you ride.

Although complete protection is not possible, wearing proper gear can reduce the chance of injury when you ride.

Following are suggestions to help you choose the proper gear.

Helmets and Eye Protection

Your helmet is your most important piece of riding gear because it offers the best protection against head injuries. A helmet should fit your head comfortably and securely.

Are You Ready to Ride?

An open-face helmet offers some protection, but a full-face helmet offers more. Regardless of the style, look for a DOT (Department of Transportation) sticker in any helmet you buy (USA only). Always wear a face shield or goggles to protect your eyes and help your vision.

WARNING

Operating this ATV without wearing an approved motorcycle helmet, eye protection, and protective clothing could increase your chances of severe injury or death in the event of an accident.

Always wear an approved motorcycle helmet that fits properly and wear eye protection (goggles or face shield), gloves, boots, long-sleeved shirt or jacket and long pants.

Additional Riding Gear

In addition to a helmet and eye protection, we also recommend:

- Sturdy off-road motorcycle boots to help protect your feet, ankles, and lower legs.
- Off-road motorcycle gloves to help protect your hands.
- Riding pants with knee and hip pads, a riding jersey with padded elbows, and a chest/shoulder protector.

Are You Ready to Ride?

Rider Training

Developing your riding skills is an on-going process. Even if you have ridden other ATVs, take time to become familiar with how this ATV works and handles. Practice riding the ATV in a safe area to build your skills. Do not ride in rough terrain until you get accustomed to the ATV's controls, and feel comfortable with its size and weight.

We urge all riders to take a certified course approved by the ATV Safety Institute (ASI). For information about the ASI training course nearest you, call the national toll-free number; (800) 887-2887 (USA only).

Other riding tips can be found in the *Tips & Practice Guide for the ATV Rider* booklet that came with your ATV (USA only).

WARNING

Operating this ATV without proper instruction could increase your risk of an accident which could lead to serious injury or death.

Beginning and inexperienced operators should complete the certified training course offered by Honda. They should then regularly practice the skills learned in the course and the operating techniques described in the owner's manual.

Are You Ready to Ride?

Age Recommendation

The minimum recommended age for this ATV model is 16. For safety, never let children under 16 years old operate this vehicle.

WARNING

A child using an ATV that is not recommended for their age could lose vehicle control while riding, resulting in severe injury or death.

A child under 16 should never operate an ATV with engine size greater than 90cc.

No Passengers

This ATV is designed as an operator-only vehicle. The long seat is designed to allow the rider to change body position, not for carrying a passenger. Never let a passenger ride on the seat or on the front or rear cargo racks.

WARNING

Carrying a passenger on this ATV greatly reduces your ability to balance and control this ATV and could cause a crash and you or your passenger could be injured or killed.

Never carry a passenger on this ATV.

Are You Ready to Ride?

No Alcohol or Drugs

Alcohol, drugs and ATVs don't mix. Even a small amount of alcohol can impair your ability to operate an ATV safely. Likewise, drugs — even if prescribed by a physician — can be dangerous while operating an ATV. Consult your doctor to be sure it is safe to operate a vehicle after taking medication.

WARNING

Operating this ATV after consuming alcohol or drugs can seriously affect your judgement, cause you to react more slowly, affect your balance and perception, and result in serious injury or death.

Never consume alcohol or drugs before or while operating this ATV.

Is Your ATV Ready to Ride?

Before each ride, it's important to inspect your ATV and make sure any problem you find is corrected. A pre-ride inspection is a must, not only for safety, but because having a breakdown, or even a flat tire, can be a major inconvenience.

If your ATV has overturned or been involved in a collision, do not ride the vehicle until it has been inspected by your Honda dealer. There may be damage or other problems you cannot see.

WARNING

Improperly maintaining this ATV or failing to correct a problem before riding can cause a crash in which you can be seriously hurt or killed.

Always perform a pre-ride inspection before every ride and correct any problems.

Pre-ride Inspection

Check the following items before you get on the ATV:

Engine Oil

Check the level and add oil if needed (page 117).

Check for leaks.

Fuel

Check the level and add fuel (page 112) if needed. Also make sure the fuel fill cap is securely fastened.

Check for leaks.

Is Your ATV Ready to Ride?

- Tires* Use a gauge to check the air pressure. Adjust if needed. Also look for signs of damage or excessive wear (page 160).
- Driveshaft Boots* Check for damage (page 165).
- Nuts & Bolts* Check the wheels to see that the axle nuts are tightened. Use a wrench to make sure all accessible nuts, bolts, and fasteners are tight.
- Underbody & Exhaust System* Check for, and remove, any dirt, vegetation or other debris that could be a fire hazard or interfere with the proper operation of the vehicle.
- Air Cleaner Housing Drain Tube* Check for deposits in the drain tube. If necessary, clean the tube (page 132) and check the air cleaner housing.
- Leaks, Loose Parts* Walk around your ATV and look for anything that appears unusual, such as a leak or loose cable.
- Cable* Check the cable housings for wear. Check the fittings for looseness. Replace or tighten as needed.
- Lights* Make sure the headlight, brakelight and taillight are working properly.

If you are carrying cargo, also check the following:

- Loading Limits* Make sure you do not exceed the load limits (page 57).

Is Your ATV Ready to Ride?

Cargo Check that all cargo is secure.

Check these items after you get on the ATV:

Throttle Check the freeplay and adjust if needed. Press the throttle to make sure it moves smoothly without sticking, and snaps shut automatically when it is released, in all steering positions (page 133).

Brakes Squeeze the front and rear brake levers and step on the rear brake pedal to check that the controls operate normally. Check for proper freeplay (pages 149, 151). Make sure there is no brake fluid leakage.

Reverse Assist Lever Check the freeplay and adjust if needed (page 137). Make sure the lever operates smoothly without sticking.

Headlight and Headlight Dimmer Switch Check for proper function (page 32).

Engine Stop Switch Check for proper function (page 31).

Steering Check that the wheels turn properly as you steer the handlebar. Move the handlebar right and left and check that there is no excessive backlash.

Remember, be sure to take care of any problem you find, or have your Honda dealer correct it before you ride.

Load Limits & Guidelines

Your Honda was designed as a rider-only ATV. It was not designed to carry a passenger. It can carry cargo on the cargo racks, however, carrying cargo anywhere else or carrying a passenger could interfere with your balance and control of the ATV.

In addition, exceeding the weight limits or carrying an unbalanced load can seriously affect your ATV's handling, braking and stability. Adding accessories or making modifications that change this ATV's design and performance can also make it unsafe. Also, the weight of any accessories will reduce the maximum load the ATV can carry.

More specific information on load limits, accessories, and modifications follows.

Loading

How much weight you put on your ATV, and how you load it, are important to your safety. If you decide to carry cargo, you should be aware of the following information.

⚠ WARNING

Overloading, improper loading, or carrying a passenger can cause a crash and you can be seriously hurt or killed.

Follow all load limits and other loading guidelines in this manual.

Load Limits & Guidelines

Load Limits

Following are the load limits for your ATV:

There are limits to how much weight can be carried on your ATV and be pulled in a trailer.

The following load limits apply to standard equipment only. Modifying your ATV, using non-standard equipment, or riding on terrain that is not flat and smooth could further reduce these limits.

maximum weight capacity 485 lbs (220 kg)
(includes the weight of the rider, all cargo, and accessories.)

front cargo rack weight limit = 66 lbs (30 kg)

rear cargo rack weight limit = 133 lbs (60 kg)

tow weight limit = 850 lbs {385 kgf}

(Combined weight of the trailer (3776 N)

and all cargo in the trailer)

tongue weight = 30 lbs {14 kgf}

(Weight on the trailer tongue) (137 N) recommended

tongue and rear cargo weight = 133 lbs (60 kg) maximum

(Combined weight on the trailer

tongue and on the rear cargo

rack)

Tongue weight can be measured with an ordinary bathroom scale. Place the scale under the tongue, using either a tongue jack or other support to keep the trailer level.

The weight of added accessories will reduce the maximum cargo weight you can carry.

Load Limits & Guidelines

Loading Guidelines

Carrying cargo or pulling a trailer will affect how your ATV handles and greatly reduce its ability in accelerating, braking and making turns and other maneuvers.

Be sure to observe the weight limits and follow these guidelines:

- Check that the tires are properly inflated.
- Do not place cargo anywhere on the ATV other than on the front and rear racks. Otherwise, operating stability may be adversely affected.
- Never ride with a passenger on the front or rear cargo racks. The ATV is not designed to carry a passenger.
- Use the trailer hitch to tow another vehicle or trailer. Do not tow by tying a rope or cable to the rear rack.
- Load cargo on the rear rack as far forward as possible. Make sure cargo on the front rack does not interfere with handlebar movement.
- Do not allow cargo to extend beyond the edges of either the front or rear racks.
- Make sure all cargo is secured before riding.
- Balance cargo weight evenly on both sides.
- Never exceed the maximum weight limit.
- When towing a trailer, take care to maintain balance and stability. Distribute cargo between the front and rear of the trailer to obtain the recommended tongue weight.
- Allow extra room for starting, stopping and turning whenever you carry cargo or pull a trailer.
- Avoid riding on steep slopes when carrying cargo or pulling a trailer.
- Never cross a slope when towing a trailer.

Accessories & Modifications

Modifying your ATV or using non-Honda accessories can make your ATV unsafe.

Before you consider making any modifications or adding an accessory, be sure to read the following information.

⚠ WARNING

Improper accessories or modifications can cause a crash in which you can be seriously hurt or killed.

Follow all instructions in this owner's manual regarding accessories and modifications.

Accessories

We strongly recommend that you use only genuine Honda accessories that have been specifically designed and tested for your ATV. Because Honda cannot test all other accessories, you must be personally responsible for proper selection, installation, and use of non-Honda accessories.

Check with your Honda dealer for assistance and always follow these guidelines:

- Make sure the accessory does not obscure any lights, reduce ground clearance, limit suspension travel or steering travel, or interfere with operating any controls.
- Make sure the accessory does not interfere with your ability to shift body position on the seat or operate hand and foot controls.
- Do not add any electrical equipment that will exceed the vehicle's electrical system capacity (page 213). A blown fuse can cause a loss of lights or engine power (page 198).

Accessories & Modifications

Modifications

We strongly advise you not to remove any original equipment or modify your ATV in any way that would change its design or operation. Such changes could seriously impair your ATV's handling, stability, and braking, making it unsafe to ride.

We also advise you not to make any modifications or remove any equipment (such as the USDA qualified spark arrester or emission control system components) that would make your ATV illegal in your area.

Removing or modifying your lights, exhaust system, emission control system, or other equipment can also make your ATV illegal.

Basic Operation & Riding

This section gives basic riding instructions, including how to start and stop your engine, and how to use the throttle and brakes. It also provides important information on riding with cargo.

To protect your new engine and enjoy optimum performance and service life, refer to Break-in Guidelines (page 214).

For information about carburetor adjustment for riding at high altitude, see page 215.

Safe Riding Precautions.....	63
Off-Road Use Only.....	63
Keep Hands and Feet on Controls.....	64
Control Speed.....	65
Use Care on Unfamiliar or Rough Terrain.....	66
Do Not Perform Stunts.....	67
Starting & Stopping the Engine	68
Preparation	68
Starting Procedure	69
Flooded Engine	71
Stalled Engine	71
How to Stop the Engine	72
Using the Recoil Starter	73
Shifting Gears	74
Riding in Reverse.....	77

(cont'd)

Basic Operation & Riding

Braking.....	79
Riding Your ATV	81
Making Turns.....	81
Skidding or Sliding	83
Riding Up Hills	84
Riding Down Hills	88
Crossing or Turning on Hills or Slopes.....	89
Riding Over Obstacles	91
Riding Through Water	92
Parking	93

Safe Riding Precautions

Before riding your ATV for the first time, please review the *ATV Safety* section beginning on page 1, and the *Before Riding* section beginning on page 47 .

Even if you have ridden other ATVs, take time to become familiar with how this ATV works and handles. Practice in a safe area until you build your skills and get accustomed to the ATV's size and weight.

Off-Road Use Only

Your ATV and its tires are designed and manufactured for off-road use only, not for pavement. Riding on pavement can affect handling and control. You should not ride your ATV on pavement.

WARNING

Operating this ATV on paved surfaces may seriously affect handling and control of the ATV, and may cause the vehicle to go out of control.

Never operate the ATV on any paved surfaces, including sidewalks, driveways, parking lots and streets.

When riding off-road, also remember to always obey local off-road riding laws and regulations. Obtain permission to ride on private property. Avoid posted areas and obey "no trespassing" signs.

Safe Riding Precautions

You should never ride your ATV on public streets, roads or highways, even if they are not paved. Drivers of street vehicles may have difficulty seeing and avoiding you, which could lead to a collision. In many states it is illegal to operate ATVs on public streets, roads and highways.

WARNING

Operating this ATV on public streets, roads or highways could cause you to collide with another vehicle.

Never operate this ATV on any public street, road or highway, even a dirt or gravel one.

Keep Hands and Feet on Controls

Always keep both hands on the handlebars and both feet on the footpegs when riding your ATV. This is important to maintain your balance and to control the vehicle. Removing even one hand from the handlebars or one foot from the footpegs can reduce your ability to control the ATV or could cause you to lose your balance and fall off the ATV.

WARNING

Removing hands from handlebars or feet from footpegs during operation can reduce your ability to control the ATV or could cause you to lose your balance and fall off of the ATV.

Always keep both hands on the handlebars and both feet on the footpegs of your ATV during operation.

Safe Riding Precautions

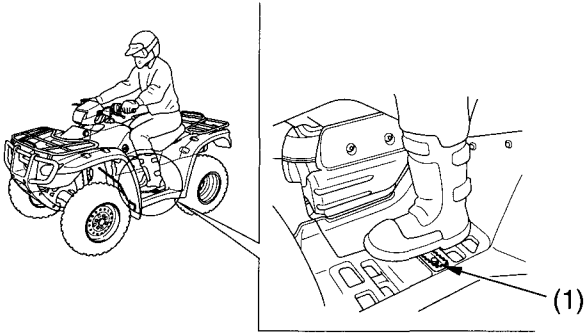

(1) footpeg

Control Speed

Riding at excessive speed increases the chance of an accident. In choosing a proper speed, you need to consider the capability of your vehicle, the terrain, visibility and other operating conditions, plus your own skills and experience.

⚠ WARNING

Operating this ATV at excessive speeds increases your chances of losing control of the ATV, which can result in an accident.

Always go at a speed that is proper for your vehicle, the terrain, visibility and other operating conditions, and your experience.

Safe Riding Precautions

Use Care on Unfamiliar or Rough Terrain

Before riding in a new area, always check the terrain thoroughly. Don't ride fast on unfamiliar terrain or when visibility is limited. (It's sometimes difficult to see obstructions like hidden rocks, bumps, or holes in time to react.)

WARNING

Failure to use extra care when operating this ATV on unfamiliar terrain could result in the ATV overturning or going out of control.

Go slowly and be extra careful when operating on unfamiliar terrain. Always be alert to changing terrain conditions when operating the ATV.

Safe Riding Precautions

Never ride past the limit of visibility. Maintain a safe distance between your ATV and other off-road vehicles. Always exercise caution, and use extra care on rough, slippery and loose terrain.

WARNING

Failure to use extra care when operating on excessively rough, slippery or loose terrain could cause loss of traction or vehicle control, which could result in an accident, including an overturn.

Do not operate on excessively rough, slippery or loose terrain until you have learned and practiced the skills necessary to control the ATV on such terrain. Always be especially cautious on these kinds of terrain.

Do Not Perform Stunts

You should always operate your ATV in a safe and reasonable manner. When riding, always keep all four wheels on the ground.

WARNING

Attempting wheelies, jumps, and other stunts increases the chance of an accident, including an overturn.

Never attempt stunts, such as wheelies or jumps. Don't try to show off.

Starting & Stopping the Engine

Always follow the proper starting procedure described below.

For your safety, avoid starting or operating the engine in an enclosed area such as a garage. Your ATV's exhaust contains poisonous carbon monoxide gas which can collect rapidly in an enclosed area and cause illness or death.

Preparation

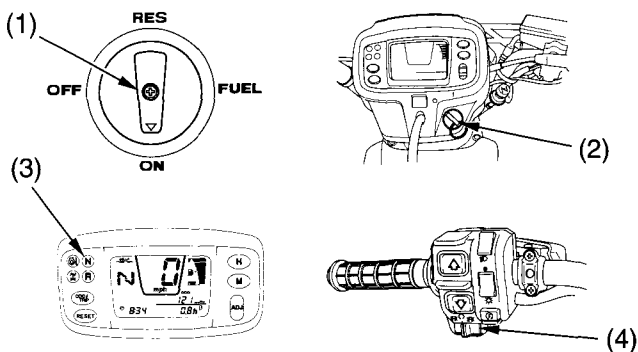

(1) fuel valve

(2) ignition switch

(3) neutral indicator

(4) engine stop switch

1. Before starting, select a level surface and lock the parking brake (page 38).
2. Turn the fuel valve (1) and ignition switch (2) to ON (I).

Confirm the following:

- The transmission is in neutral (neutral indicator (3) ON).
- The engine stop switch (4) is set to RUN (O).

Starting & Stopping the Engine

Starting Procedure

To restart a warm engine, follow the procedure for “*High Air Temperature.*”

Normal Air Temperature 10° – 35°C (50° – 95°F)

CENTER OF HANDLEBAR

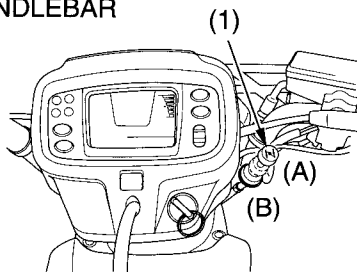

(1) choke knob

(A) fully ON

(B) fully OFF

1. If the engine is cold, pull the choke knob (1) up all the way to fully ON (A) position.
2. With the throttle closed, press the start button.
 - Pressing the electric start button for more than 5 seconds at a time may cause the starter to overheat and damage the starter. Release the start button for approximately 10 seconds before pressing it again.
3. Immediately after the engine starts, operate the choke knob to keep fast idle.
4. Continue warming up the engine until it runs smoothly and responds to the throttle with the choke knob in the fully OFF (B) position.
5. If idling is unstable, open the throttle slightly.

Starting & Stopping the Engine

High Air Temperature 35°C (95°F) or above

LEFT HANDLEBAR

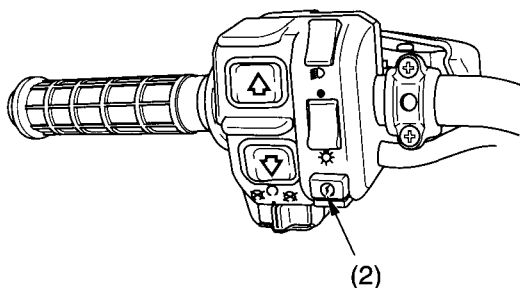

(2) start button

1. Do not use the choke.
2. With the throttle closed, press the start button (2).

Low Air Temperature 10°C (50°F) or below

Follow the procedure for “*Normal Air Temperature.*”

When air temperature is below -15°C (5°F), push the starting primer knob two or three times (page 33).

NOTICE

Extended use of the choke may impair piston and cylinder wall lubrication and shorten the life of the engine.

Do not race the engine during the warm-up period.
Racing a cold engine wastes fuel and increases engine wear.

Starting & Stopping the Engine

Flooded Engine

If the engine fails to start after repeated attempts, it may be flooded with excess fuel. To clear a flooded engine:

1. Leave the engine stop switch set to RUN (\odot).
2. Push the choke knob down all the way to fully OFF.
3. Open the throttle fully.
4. Press the start button for 5 seconds (or operate the recoil starter several times).
5. If the engine starts, quickly close the throttle, then, if idling is unstable, open it slightly.

If the engine does not start, wait 10 seconds, then follow the *High Air Temperature* procedure (page 70).

If the engine still won't start, refer to *If Your Engine Quits or Won't Start*, page 188.

Stalled Engine

You can restart the engine while the vehicle is stopped by squeezing the front brake lever and pressing the start button.

Do not press the throttle lever while starting in gear. Your ATV is equipped with a start inhibitor system that will cut off the ignition if the throttle is open while attempting to start in gear.

Once you have started the engine, release the front brake lever, then apply throttle gradually.

Starting & Stopping the Engine

How to Stop the Engine

Normal Engine Stop

To stop the engine, make sure the transmission is in neutral by checking that the neutral indicator lights, and turn the ignition switch OFF (\circ).

The engine stop switch should normally remain in the RUN (\circ) position even when the engine is OFF.

If your ATV is stopped with the engine stop switch OFF (\otimes) and the ignition switch ON (\uparrow), the battery will discharge.

Emergency Engine Stop

To stop the engine in an emergency, use the engine stop switch. To operate, slide the switch to the OFF (\otimes) position.

Starting & Stopping the Engine

Using the Recoil Starter

The recoil starter is used to start the engine when the battery is low.
To operate the recoil starter:

1. Check that the transmission is in neutral.
2. Unsnap and remove the right side cover (1).
3. Grasp the starter grip (2) firmly, then pull it out slowly approximately 4 in (100 mm).
4. Pull the grip up briskly and fully.
5. After the engine starts, allow the starter grip to return slowly.

If the starter grip does not return smoothly (because of dirt in the assembly), see your Honda dealer.

RIGHT SIDE

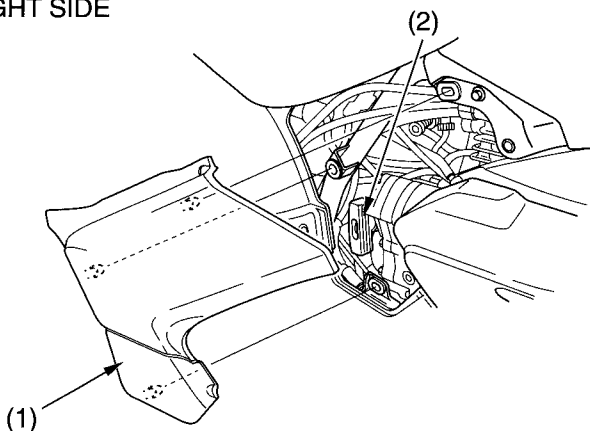

(1) right side cover

(2) starter grip

Shifting Gears

UPSHIFTING SEQUENCE

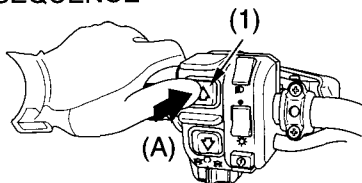

DOWNSHIFTING SEQUENCE

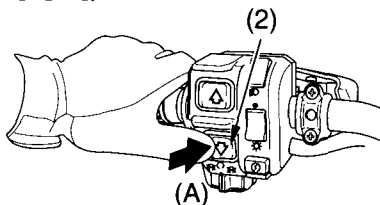

(1) upshift switch

(A) push

(2) downshift switch

Your ATV has five forward gears: 1, 2, 3, 4, and 5.

Two gearshift switches are located next to the left handlebar grip: upshift (\triangle) and downshift (∇).

To upshift the transmission, press the upshift switch (1) once.

To downshift the transmission, press the downshift switch (2) once.

To select reverse, use the reverse selector knob (page 77).

After starting the engine and letting it warm up, follow these procedures:

1. With the transmission in neutral, release the parking brake, but continue squeezing the rear brake lever.
2. With the throttle closed, press the upshift switch once to shift into 1st gear.

Shifting Gears

3. Release the rear brake lever and increase engine speed by gradually opening the throttle.
4. When speed increases, release the throttle and shift to 2nd gear by pressing the upshift switch once.
5. Repeat this sequence to progressively upshift to 3rd, 4th and 5th (top) gear.
6. To downshift, press the downshift switch once. Remember to close the throttle each time you shift to the next lower gear.

The transmission cannot be upshifted from neutral to 1st gear when the engine speed is above 3,000 rpm or the ground speed is above 7 mph (11 km/h).

The transmission cannot be downshifted from 1st gear to neutral when the ground speed is above 2 mph (3 km/h).

If the electric shift system malfunctions, the transmission cannot be shifted by pressing the gearshift switches. See your Honda dealer. (In an emergency, a gear may be selected manually so you may move the vehicle. See *Emergency Gear Selection & Operation*, page 192).

Learning when to shift gears comes with experience. Keep the following tips in mind:

- As a general rule, shift while moving in a straight line.
- Close the throttle completely before shifting. Improper shifting may damage the engine, transmission, and drive train.
- Upshift to a higher gear or reduce throttle before engine rpm (speed) gets too high. Learn the relationship between engine sound and the normal shifting points.

(cont'd)

Shifting Gears

- Downshift to a lower gear before you feel the engine laboring (lugging) at low rpm.
- Avoid downshifting to help slow your ATV when engine rpm is high. Downshifting when engine speed is near its allowable maximum may over-rev the engine and cause possible damage.
- To prevent transmission damage, do not coast or tow the ATV for long distances with the engine off.

Recommended Shift Points

Ride in the highest gear that lets the engine run and accelerate smoothly. This will give you good fuel economy and effective emissions control.

Riding in Reverse

If you need to ride in reverse, make sure the area behind you is clear and only operate the ATV at low speed.

⚠ WARNING

Improperly operating in reverse could cause you to hit an obstacle or person behind you, resulting in serious injury.

Make sure there are no obstacles or people behind you before selecting reverse gear. When it is safe to proceed, go slowly.

1. Bring the vehicle to a complete stop, then make sure the transmission is in neutral.
2. Be sure there are no obstacles or people in the way.
3. While pushing the reverse selector knob (1) in, squeeze the rear brake lever/parking brake lever (2), then press the downshift switch (3) once to shift into "R" (reverse) gear.

LEFT HANDLEBAR

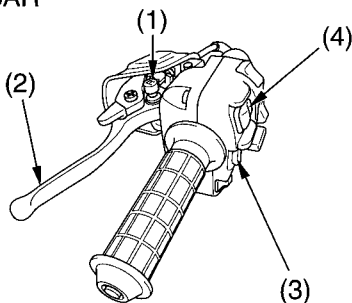

(1) reverse selector knob
(2) rear brake lever/
parking brake lever

(3) downshift switch
(4) upshift switch

(cont'd)

Riding in Reverse

4. Release the rear brake lever/parking brake lever.
5. Open the throttle gradually and ride slowly. Do not open the throttle suddenly or make abrupt turns.
6. To stop, close the throttle and gradually apply both the front and rear brakes. Do not abruptly apply the rear brake by itself.
7. To shift out of reverse and into neutral, press the upshift switch (4) once to shift into “N” (neutral) gear.

The transmission cannot be shifted from neutral back into reverse when the engine speed is above 3,000 rpm or speed of your ATV is above 2 mph (3 km/h).

WARNING

Applying only the rear brake abruptly when operating in reverse gear could cause the front wheels to lift off the ground and the ATV could overturn backwards.

Carefully apply both the front and rear brakes when stopping in reverse gear.

Braking

Your ATV is equipped with disc brakes on both front wheels which are hydraulically activated by operating the right brake lever. A single drum brake on the rear axle housing is mechanically activated by depressing the brake pedal or operating the left brake lever.

Although the front and rear brakes have separate controls, all four wheels are interconnected when your ATV is in the 4WD mode. So operating any brake control in the 4WD mode will cause braking at both the front and rear wheels.

As a general rule, the front braking system provides about 70 percent of total stopping power.

For full braking effectiveness, use both the pedal and lever simultaneously. Using both braking systems will stop your ATV faster with greater stability.

To slow or stop, apply the brake lever and brake pedal smoothly, while downshifting to match your speed.

Gradually increase braking as you feel the brakes slowing your speed. The increase in engine compression from downshifting will help slow your ATV.

Applying the brakes too hard may cause the wheels to lock and slide, reducing control of your ATV. If this happens, release the brake controls, steer straight (if possible) ahead until you regain control, then reapply the brakes more gently.

When possible, reduce your speed or complete braking before entering a turn. Avoid braking or closing the throttle quickly while turning. Either action may cause one or more wheels to slip and reduce your control of your ATV.

Braking

Your ability to brake in a turn and to brake hard in an emergency situation are important riding skills.

When descending a long, steep grade, use engine compression braking by downshifting, with intermittent use of both brakes. Continuous brake application can overheat the brakes and reduce their effectiveness.

Riding with your foot resting on the brake pedal or your hands on the brake levers may overheat the brakes, reducing effectiveness.

For information on how to apply the brakes in various riding situations, see the following section, *Riding Your ATV*.

Riding Your ATV

Making Turns

Learn how to turn your ATV properly. Practice the techniques outlined in this section on level ground and at low speeds until you are confident in making turns.

WARNING

Turning improperly can make the ATV go out of control, causing a collision or overturn.

- Always follow proper procedures for turning as described in this owner's manual.
- Practice turning at low speeds before attempting to turn at faster speeds.
- Do not turn at excessive speeds.

Riding Your ATV

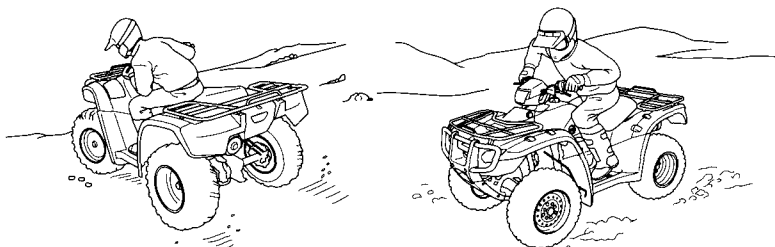

Lean your body to the inside of a turn and forward.

To make a turn on level ground: Steer the handlebar and lean your body toward the inside of the turn. Leaning helps balance the vehicle, and it feels more comfortable. Leaning into a turn is an important technique to master in riding an ATV.

To make a sharp turn at low speed: It helps to shift your body slightly forward on the seat, and lean inside, as you steer the handlebar. Shifting weight forward allows the rear wheels to turn easier, and it also improves front-wheel steering.

To make a turn from a full stop: Apply the throttle gradually when you turn and start up at the same time. Remember to shift your body forward to make sharp low-speed turns and whenever you turn while accelerating from a full stop.

Riding Your ATV

Skidding or Sliding

The terrain surface can be a major factor affecting turns. Skidding during a turn is more likely to occur on slippery surfaces, such as snow, ice, mud and loose gravel. If you skid on ice, you may lose all directional control. To avoid skidding on slippery terrain, keep your speed low and ride with caution.

WARNING

Skidding or sliding improperly may cause you to lose control of this ATV. You may also regain traction unexpectedly, which may cause the ATV to overturn.

Learn to safely control skidding by practicing at low speeds and on level, smooth terrain.

If your ATV skids sideways during a turn, steer in the direction of the skid. Avoid hard braking or accelerating until you have regained directional control.

Riding Your ATV

Riding Up Hills

The ATV's ability to safely climb hills largely depends on the rider's skill and judgment. Begin by practicing on smooth, gentle slopes. As you gain experience, you'll learn the hazards and your own limitations. You may then proceed to ride on more difficult terrain. However, you must be able to decide which hills or hazards might cause the ATV to overturn. Avoid excessively steep hills.

WARNING

Operating on excessively steep hills can cause the vehicle to overturn more easily than operating on level surfaces or small hills.

Never operate the ATV on hills too steep for the ATV or for your abilities.

When climbing hills, you must shift weight toward the front wheels to help keep them on the ground. To do this, shift your body slightly forward on the seat and lean forward. For greater weight shift, move your body farther forward and lean forward.

WARNING

Climbing hills improperly could cause loss of control or cause the ATV to overturn.

Always follow proper procedures for climbing hills as described in this owner's manual.

Riding Your ATV

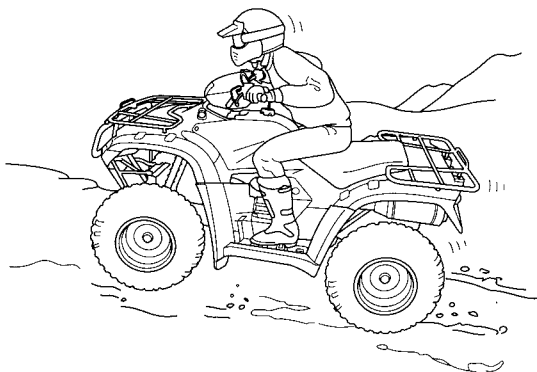

Shift weight forward when climbing hills.

- Always check the terrain carefully before you start up any hill.
- Never climb hills with excessively slippery or loose surfaces.
- To climb a hill, take a running start in an appropriate gear and speed for the conditions. Maintain a steady speed as you ascend the hill.
- Never open the throttle suddenly or make sudden gear changes. The ATV could flip over backward.
- Never go over the top of any hill at high speed. An obstacle, a sharp drop, or another vehicle or person could be on the other side of the hill.

Riding Your ATV

Stalling the ATV and/or Rolling Backwards:

If you incorrectly estimate climbing capability or terrain conditions, the ATV may not have enough power or traction to continue uphill. If this happens, the ATV can stall and/or roll backwards.

⚠ WARNING

Stalling, rolling backwards or improperly dismounting while climbing a hill could result in the ATV overturning.

Always follow proper procedures for climbing a hill as described in this owner's manual.

What to do if the ATV stalls or rolls backwards when climbing a hill:

If you are about to lose all forward speed:

1. Using the front and rear brakes together, bring the ATV to a stop with the vehicle pointed straight uphill.
2. Get off the ATV while you continue holding the brakes.
3. Shift into neutral, set the parking brake and turn the engine off.
4. Then assess the situation.

If the ATV starts rolling backwards before you begin braking:

1. Keep your weight uphill.
2. Carefully apply the front brakes first, then carefully apply the rear brake. Do not apply either brake abruptly if you are rolling backwards, or the vehicle may overturn.

If the ATV continues sliding backwards:

After you've applied the brakes, get off and away from the vehicle.

Remember that operating any brake control in the 4WD mode will cause braking at both the front and rear wheels.

Riding Your ATV

What to do after the ATV has stalled or rolled backwards:

If the hill is too steep or too slippery, or if you have any doubt whether you can safely walk the ATV back down the hill, leave the vehicle where it is and get help. If possible, block the wheels so the vehicle doesn't roll backwards.

If the hill is not too steep and you have good footing, you may be able to walk the ATV back down the hill. Make sure your intended path is clear in case you lose control of the ATV.



Be sure your legs are clear of the wheels.

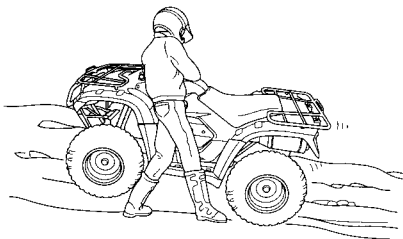

Body position for backing down a hill.

1. Stand with your body facing downhill, beside the vehicle so you can reach the rear brake lever with your right hand.
2. Be sure your legs are clear of the wheels.
Check your footing.
3. Slowly and carefully back the ATV down the hill using the rear brake lever to control speed.
4. If you lose control of the ATV, for your safety, get away from the vehicle.

Riding Your ATV

Riding Down Hills

It's usually advisable to descend hills with the ATV pointed straight downhill. Avoid angles that would cause the vehicle to lean sharply to one side.

⚠ WARNING

Going down a hill improperly could cause loss of control or cause the ATV to overturn.

Always follow proper procedures for going down hills as described in this owner's manual.



On downhills, shift your weight back.

As you approach a downhill, stop and survey the terrain below. Never ride past the limit of your visibility. Never go down a hill at high speed.