

**2005
Honda TRX650FA/FGA
Fourtrax Rincon/with GPScape
OWNER'S MANUAL**

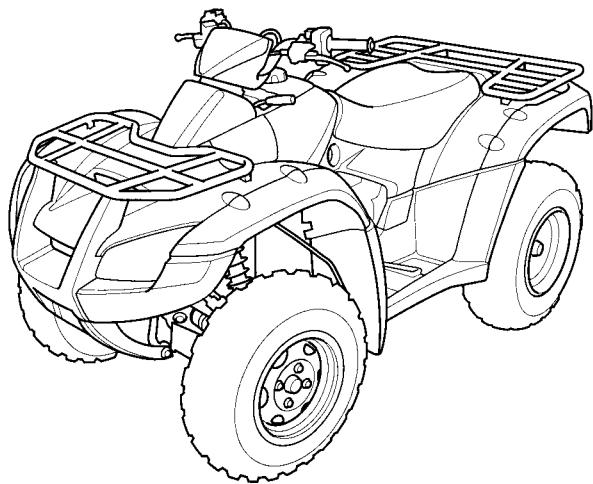

FOR OFF-ROAD USE ONLY

This vehicle is designed and manufactured for off-road use only.
USA only:

It conforms to US EPA Noise Emission regulations, but does not conform to Federal Motor Vehicle Safety Standards or US EPA On Highway Exhaust Emission regulations, and operation on public streets, roads, or highways is illegal. The vehicle is equipped with a USDA qualified spark arrester. Obey local laws and regulations.

It conforms to California exhaust emission regulations for ATVs.

Introduction

Congratulations on choosing your Honda ATV.

When you own a Honda, you're part of a worldwide family of satisfied customers — people who appreciate Honda's reputation for building quality into every product.

Your Honda was designed as a recreational ATV for off-road use by one rider only.

Before riding, take time to get acquainted with your ATV and how it works. To protect your investment, we urge you to take responsibility for keeping your ATV well maintained. Scheduled service is a must, of course. But it's just as important to observe the break-in guidelines, and perform all pre-ride and other periodic checks detailed in this manual.

We also recommend that you read this owner's manual before you ride. It's full of facts, instructions, safety information, and helpful tips. To make it easy to use, the manual contains a detailed list of topics at the beginning of each section, and both an in-depth table of contents and an index at the back of the book.

As you read this manual, you will find information that is preceded by a **NOTICE** symbol. This information is intended to help you avoid damage to your Honda, other property, or the environment.

Read the Warranties Booklet (page 255) thoroughly so you understand the coverages that protect your new Honda and are aware of your rights and responsibilities.

Whenever you ride, tread lightly. By staying on established trails and riding only in approved areas, you help protect the environment and keep off-road riding areas open for the future.

Introduction

If you have any questions, or if you ever need special service or repairs, remember that your Honda dealer knows your ATV best and is dedicated to your complete satisfaction.

Please report any change of address or ownership to your Honda dealer so we will be able to contact you concerning important production information.

You may also want to visit our website at www.honda.com.

Happy riding!

California Proposition 65 Warning

WARNING: This product contains or emits chemicals known to the State of California to cause cancer and birth defects or other reproductive harm.

A Few Words About Safety

Your safety, and the safety of others, is very important. And operating this ATV safely is an important responsibility.

To help you make informed decisions about safety, we have provided operating procedures and other information on labels and in this manual. This information alerts you to potential hazards that could hurt you or others.

Of course, it is not practical or possible to warn you about all hazards associated with operating or maintaining an ATV. You must use your own good judgment.

You will find important safety information in a variety of forms, including:

Safety Labels — on the ATV.

Safety Messages — preceded by a safety alert symbol  and one of three signal words: **DANGER**, **WARNING**, or **CAUTION**.

A Few Words About Safety

These signal words mean:

▲ DANGER

You **WILL** be **KILLED** or **SERIOUSLY HURT** if you don't follow instructions.

▲ WARNING

You **CAN** be **KILLED** or **SERIOUSLY HURT** if you don't follow instructions.

▲ CAUTION

You **CAN** be **HURT** if you don't follow instructions.

Safety Headings — such as Important Safety Reminders or Important Safety Precautions.

Safety Section — such as ATV Safety.

Instructions — how to use this ATV correctly and safely.

This entire manual is filled with important safety information — please read it carefully.

Contents

These pages give an overview of the contents of your owner's manual. The first page of each section lists the topics covered in that section.

ATV Safety	1
Important safety information you should know, plus a look at the safety-related labels on your ATV.	
Instruments & Controls.....	9
The location and function of indicators and controls on your ATV and operating instructions for various controls and features.	
GPScape System (TRX650FGA only)	45
Instructions for use of your ATV Navigation System.	
Before Riding.....	73
The importance of wearing a helmet and other protective gear, how to make sure you and your ATV are ready to ride, and important information about loading.	
Basic Operation & Riding	89
How to start and stop the engine, shift gears, and brake. Also, riding precautions.	

Contents

Servicing Your Honda	125
Why your ATV needs regular maintenance, what you need to know before servicing your Honda, an owner maintenance schedule, and instructions for specific maintenance and adjustment items.	
Tips	207
How to store and transport your ATV and how to be an environmentally-responsible rider.	
Taking Care of the Unexpected	217
What to do if you have a flat tire, your engine won't start, etc.	
Technical Information	237
ID numbers, technical specifications, and other technical facts.	
Consumer Information	251
Information on warranties, emission controls, how to get Honda service manuals.	
Table of Contents	260
Sequential listing of topics in this owner's manual.	
Index	268
Quick Reference	
Handy facts about fuel, engine oil, tire sizes, and air pressures.	

ATV Safety

This section presents some of the most important information and recommendations to help you ride your ATV safely. Please take a few moments to read these pages. This section also includes information about the location of safety labels on your ATV.

Important Safety Information	2
Safety Labels.....	5

Important Safety Information

Your ATV can provide many years of service and pleasure — if you take responsibility for your own safety and understand the challenges you can meet while riding.

There is much that you can do to protect yourself when you ride. You'll find many helpful recommendations throughout this manual. The following are a few that we consider most important.

Follow the Age Recommendation

The minimum recommended age for this ATV model is 16. Children under age 16 should never operate this vehicle.

Always Wear a Helmet

It's a proven fact: helmets significantly reduce the number and severity of head injuries. So always wear an approved motorcycle helmet. We also recommend that you wear eye protection, sturdy boots, gloves, and other protective gear (page 74).

Never Carry a Passenger

Your ATV is designed for one person only. There are no handholds, footrests, or seat for a second person — so never carry a passenger. A passenger could interfere with your ability to move around to maintain your balance and control of the ATV.

Important Safety Information

Ride Off-Road Only

Your ATV is designed and manufactured for off-road use only. The tires are not made for pavement, and the ATV does not have turn signals and other features required for use on public roads. If you need to cross a paved or public road, get off and walk your ATV across.

Take Time to Learn & Practice

Even if you have ridden other ATVs, take time to become familiar with how this ATV works and handles. Practice in a safe area until you build your skills and get accustomed to the ATV's size and weight.

Because many accidents involve inexperienced or untrained riders, we urge all riders to take a training course approved by the ATV Safety Institute (ASI). See page 76.

Contact an authorized ATV dealer or call 1-800-887-2887 (USA only) to find out about the training courses nearest you.

Be Alert for Off-Road Hazards

The terrain can present a variety of challenges when you ride off-road. Continually “read” the terrain for unexpected turns, drop-offs, rocks, ruts, and other hazards. Always keep your speed low enough to allow time to see and react to hazards.

Important Safety Information

Ride within Your Limits

Pushing limits is another major cause of ATV accidents. Never ride beyond your personal abilities or faster than conditions warrant. Remember that alcohol, drugs, fatigue, and inattention can significantly reduce your ability to make good judgments and ride safely.

Don't Drink and Ride

Alcohol and riding don't mix. Even one drink can reduce your ability to respond to changing conditions, and your reaction time gets worse with every additional drink. So don't drink and ride, and don't let your friends drink and ride either.

Keep Your Honda in Safe Condition

It's important to keep your ATV properly maintained and in safe riding condition. Having a breakdown can be difficult, especially if you are stranded off-road far from your base. To help avoid problems, inspect your ATV before every ride and perform all recommended maintenance.

Safety Labels

Your ATV comes with a hang tag and several labels containing important safety information. Anyone who rides the vehicle should read and understand this information before riding.

The labels should be considered permanent parts of the vehicle. If a label comes off or becomes hard to read, contact your Honda dealer for replacements.

Safety Labels

USA only

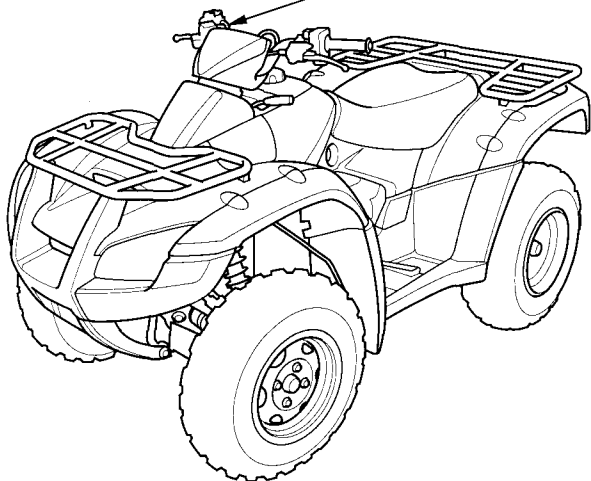
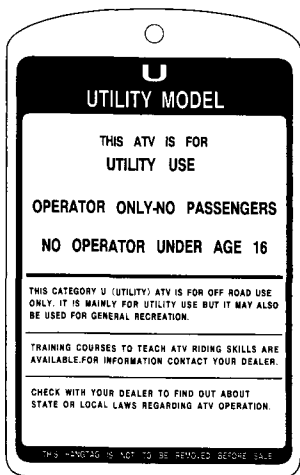
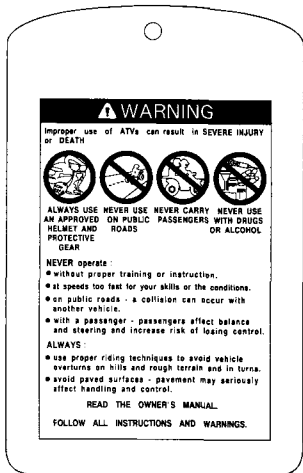

Safety Labels

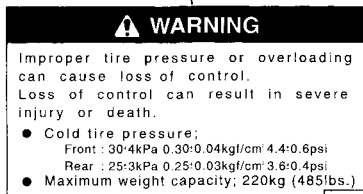
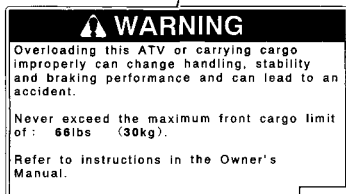
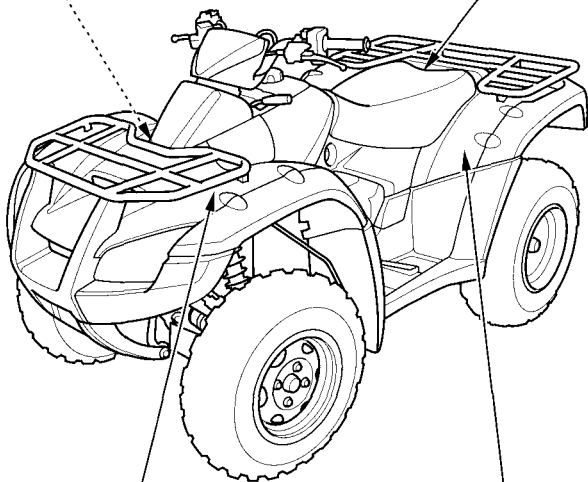

Safety Labels

WARNING



Operating this ATV if you are under the age of 16 increases your chance of severe injury or death.

NEVER operate this ATV if you are under age 16.

BRAKING INFORMATION

With four-wheel drive operating any brake control causes braking at both the front and rear wheels. For detailed braking information, refer to the Owner's Manual.

WARNING

Overloading this ATV or carrying cargo improperly can change handling, stability and braking performance and can lead to an accident.

Never exceed the maximum rear cargo limit (combined weight on the rear rack and in the storage area) of: 133 lbs (60 kg).

Refer to instructions in the Owner's Manual.

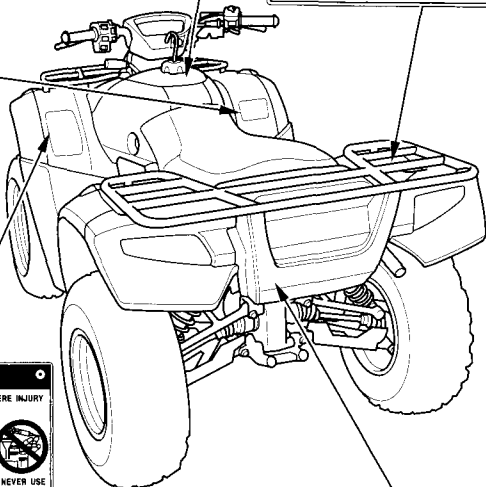

WARNING

Improper use of ATVs can result in SEVERE INJURY or DEATH



ALWAYS USE AN APPROVED HELMET AND PROTECTIVE GEAR. NEVER USE ATVs ON PUBLIC ROADS OR ALCOHOL. NEVER CARRY PASSENGERS WITH DRUGS OR ALCOHOL.

NEVER operate:

- without proper training or instruction.
- at speeds too fast for your skills or the conditions.
- on public roads - a collision can occur with another vehicle.
- with a passenger - passengers affect balance and steering and increase risk of losing control.

ALWAYS:

- use proper riding techniques to avoid vehicle overturns on hills and rough terrain and in turns.
- avoid paved surfaces - pavement may seriously affect handling and control.

READ THE OWNER'S MANUAL.

FOLLOW ALL INSTRUCTIONS AND WARNINGS.

WARNING

Towing an improperly loaded trailer can cause loss of control.

- Read owner's manual.
- Tow weight limit : 3776N (385kgf) 850lbs
- Tongue weight : 137N (14kgf) 30lbs

Instruments & Controls

This section shows the location of all indicators and controls you would normally use before or while riding your ATV.

The items listed on this page are described in this section. Instructions for other components are presented in other sections of this manual where they will be most useful.

Component Locations	11
Indicators & Displays	14
Multi-function Display	19
Drive Mode Indicator	20
Gear Position Indicator	21
Oil Change Indicator	22
Odometer	23
Tripmeter	23
Hourmeter	24
Digital Clock	25
Fuel Gauge	28

(cont'd)

Instruments & Controls

Control & Features	29
Fuel Valve	29
Choke Knob	30
Ignition Switch	31
Shift Lever	32
Drive Mode Select Switch	33
2WD/4WD Select Switch	34
Start Button	35
Engine Stop Switch	35
Headlight Switch	36
Headlight Dimmer Switch	36
Recoil Starter	37
Starting Primer Knob	37
Throttle Lever	38
Gearshift Switch	39
Front Brake Lever	40
Rear Brake Lever	40
Rear Brake Pedal	40
Parking Brake	41
Flag Pole Bracket	42
Accessory Socket	43

Component Locations

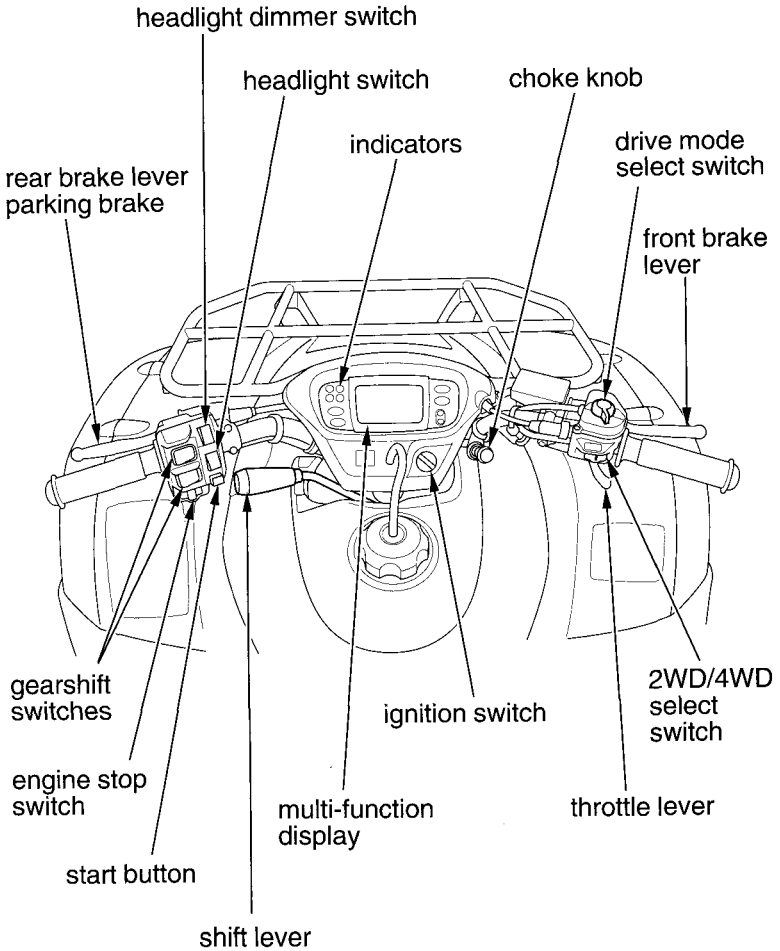

Component Locations

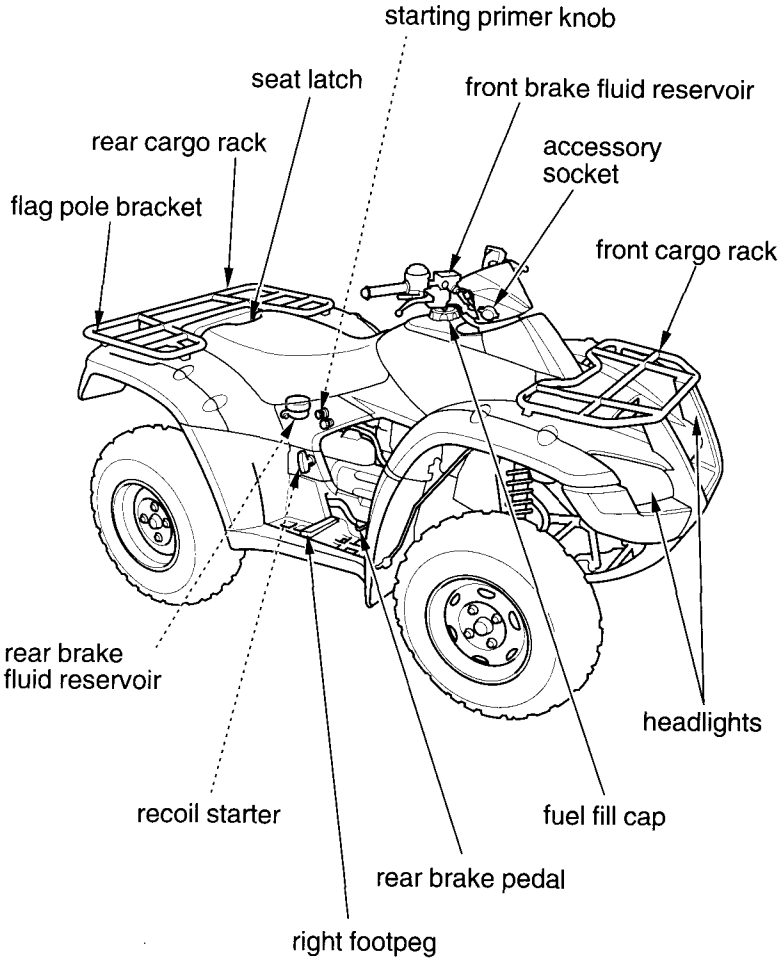

Component Locations

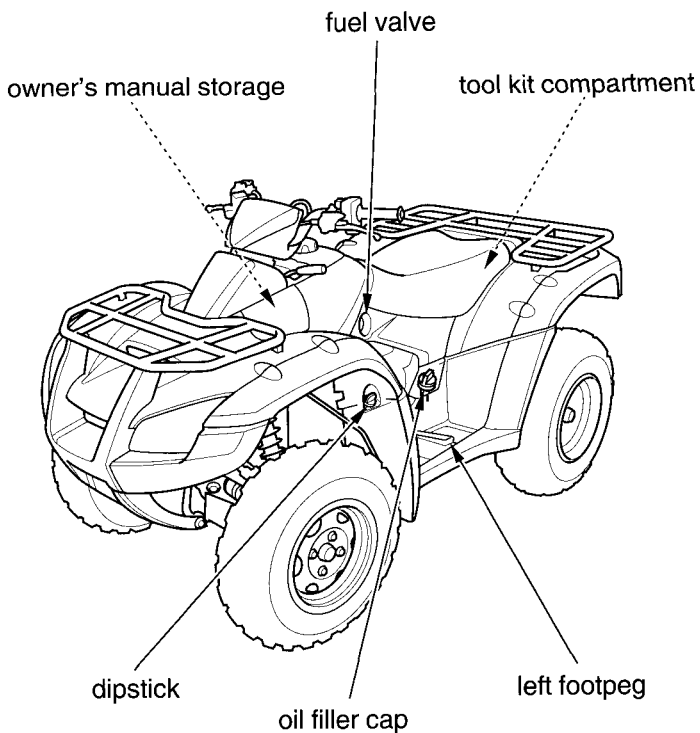

Indicators & Displays

The indicators and displays on your ATV keep you informed, alert you to possible problems, and make your riding safer and more enjoyable. Refer to the indicators frequently. Their functions are described on the following pages.

TRX650FA

TRX650FGA

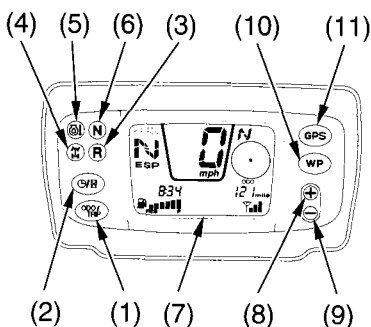
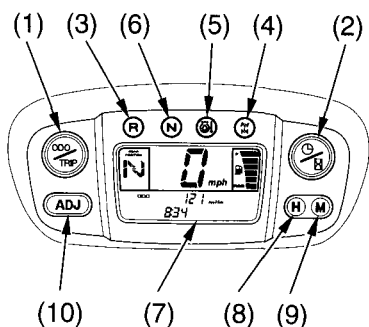

- (1) odometer/tripmeter select button
- (2) hourmeter/digital clock select button
- (3) reverse indicator
- (4) 4WD indicator
- (5) oil/coolant high temperature indicator
- (6) neutral indicator
- (7) multi-function display
- (8) hour select button
plus button (TRX650FGA)
- (9) minute select button
minus button (TRX650FGA)
- (10) adjust button
WP button (TRX650FGA)
- (11) GPS button (TRX650FGA)

Indicators & Displays

Lamp Check

The oil/coolant high temperature indicator comes on when you turn the ignition switch ON (I) so you can check that it is working. The indicator remains on until after the engine is started (TRX 650 FA only). This indicator is identified in the table on page 16 with the words: *Lamp Check*.

When applicable, the reverse or neutral indicators come on when you turn the ignition switch ON (I) and remain on until you shift out of reverse or neutral.

If one of these indicators does not come on when it should, have your Honda dealer check for problems.

Display Check

When the ignition switch is turned ON (I), the multi-function display (1) will temporarily show all the modes and digital segments so you can make sure the liquid crystal display is functioning properly.

The displays are identified in the table on page 16 with the words: *Display Check*.

If any part of these displays does not come on when it should, have your Honda dealer check for problems.

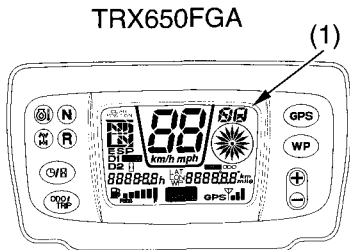
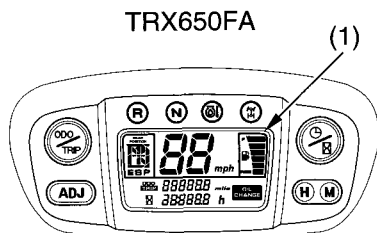

(1) multi-function display

Indicators & Displays

1	Odometer/tripmeter select button	Selects display of the odometer or tripmeter. Resets the tripmeter to zero (0) (page 23).
2	Hourmeter/digital clock select button	Selects display of the hourmeter or digital clock (pages 24 , 25).
3	Reverse indicator	Lights when the transmission is in reverse.
4	4WD indicator	Lights when the drive mode is in the 4WD mode. The 4WD indicator blinks if there is a possible problem with the 2WD/4WD select system. See your Honda dealer as soon as possible.
5	Oil/coolant high temperature indicator	Lights when engine oil and/or coolant temperature is high enough to adversely affect the service life of the engine. If the oil/coolant high temperature indicator comes on while you are riding, immediately bring the vehicle to a stop, turn the engine off and let it cool. See page 229. <i>Lamp check</i>
6	Neutral indicator	Lights when the transmission is in neutral.

Indicators & Displays

7	Multi-function display	The display includes the following functions. <i>Display Check</i> .
	Drive mode indicator	Shows the driving mode (page 20).
	Gear position indicator	Shows the gear position. (page 21)
	Speedometer	Shows riding speed.
	Fuel gauge	Shows approximate fuel supply available (page 28).
	Oil change indicator	Lights when specified maintenance interval for engine oil change is reached (page 22).
	Odometer	Shows accumulated mileage (page 23).
	Tripmeter	Shows mileage per trip (page 23).
	Hourmeter	Shows hours and tenths of hours of engine operation (page 24).
	Digital clock	Shows the time (hours and minutes) (page 25).

Indicators & Displays

8	Hour select button	Advances the hour displayed by the digital clock (page 25).
	Plus button (TRX650 FGA)	Advances the latitude and longitude when in the GPS mode.
9	Minute select button	Advances the minutes displayed by the digital clock (page 25).
	Minus button (TRX650 FGA)	Advances the latitude and longitude when in the GPS mode.
10	Adjust button	Used to set the digital clock (page 25).
	WP button (TRX650 FGA)	This button is used to input a waypoint or to erase waypoint data.
11	GPS button (TRX650 FGA)	This button is used to select the GPS navigation mode.